

POLICIES & PROCEDURES on Infection Prevention and Control



MINISTRY OF HEALTH MALAYSIA





Policies and Procedures on Infection Prevention and Control

Medical Care Quality Section,
Medical Development Division,
Ministry of Health Malaysia

Prepared in 2018
Printed in 2019
3rd edition



Copyright © MINISTRY OF HEALTH MALAYSIA

All rights reserved. This book may not be reproduced, in whole or in part, in any form or means, electronic or mechanical, including photocopying, recording, or by any information storage and retrieval system now known or here after invented, without permission from publisher.

Policies and Procedures on Infection Prevention and Control
Third Edition 2018
Printed 2019

Produced & Distributed by:

Infection Control Unit
Medical Care Quality Section
Medical Development Division
Ministry of Health Malaysia

ISBN: 978-967-2173-3

CONTENTS

Foreword by Director-General of Health, Malaysia	i
Foreword by Deputy Director-General of Health, Malaysia (Medical)	ii
Advisors	iii
List of committee members	iii
List of contributors	iv
Abbreviations	v
Chapters	
1 Infection Prevention and Control Governance	1
2 Healthcare Associated Infection Surveillance	19
3 Fundamental Principles of Infection Prevention	25
Standard Precautions	25
Hand Hygiene	25
Personal Protective Equipment (PPE)	30
Disinfection & Sterilisation	38
Environmental Hygiene	39
Waste Management	45
Linen Management	50
Spillage Management	53
Injection safety & Sharps management	55
Respiratory Hygiene & Cough Etiquette	66
Transmission Based Precautions	70
Contact	71
Droplet	73
Airborne	75
Translocation	77
4 Isolation Rooms	79
Airborne Infection Isolation Room	79



Protective Environment Room	80
Contact Isolation Room	80

Chapters

5	Clinical Practice	84
	Aseptic Technique	84
	Enteral Nutrition	87
	Parenteral Nutrition	92
	Wound Care	95
	Blood And Blood Components Transfusion	97
6	Prevention of Healthcare Associated Infections	99
	Catheter Associated Urinary Tract Infection	99
	Surgical Site Infection	103
	Hospital Acquired Pneumonia (HAP)	111
	Intravascular Catheter Related Infections	114
	Prevention of CVC-line related Infection	122
7	Infection Control in Specific Healthcare Settings	125
	General Intensive Care Unit	125
	Neonatal Intensive Care Unit	130
	Operation Theatre	137
	Dental Practice	150
	Scope Room	157
	Mortuary	159
	Burns	166
	Haematology and Oncology Unit	171
	Pharmacy	174
	Nephrology And Hemodialysis Unit	179
	Laboratory	188
	Food Services	199
8	Antimicrobial Resistance (AMR)	205
	Surveillance	206



Chapters		
	Antibiotic Surveillance	208
	Policy & Guidelines on Antimicrobial Stewardship	209
	Antimicrobial Stewardship (AMS) Protocol	210
9	Specific Microorganisms of Clinical Interest	211
	Multi-Drug Resistant Organisms	211
	Viruses	218
	Fungal Infections	220
10	Hospital Outbreak Management	223
	Steps in Outbreak Investigation and Management	223
	Unknown Pathogen Outbreak	230
11	Occupational Safety And Health For Healthcare Workers (HCW)	233
	HCW Screening and Post Exposure Prophylaxis for Blood Borne Pathogens (BPP)	234
	HCW Screening for Tuberculosis	237
	Immunisation for HCW	241
	Diphtheria and Meningococcal Chemoprophylaxis for HCW	242
12	Environmental	243
	Infection Control During Construction & Renovation	243
	Operation Theatre Commissioning	249
	Environmental Cleaning	254
13	Disinfection and Sterilization	260
14	Communication & Sharing	270
15	Education And Training	279
	Appendix	283
	References	284



FOREWORD
BY THE DIRECTOR-GENERAL OF HEALTH,
MINISTRY OF HEALTH, MALAYSIA



It is with utmost pleasure that I pen this foreword to commemorate the 3rd edition of the National Infection Prevention and Control Policies and Procedures which was put together by an impressive reputable multidisciplinary team comprising of infectious disease physicians, surgeons, microbiologists, paediatricians, pharmacists, nutritionists, engineers and many more. I would like to thank and congratulate everyone involved in producing this revised edition, especially the Infection Control Unit of Ministry of Health, Malaysia and the National Infection and Antibiotic Control Committee. They have been charged with many tasks which include reforming and consolidating the national policies with global standards to ensure that they are feasible for adaptation within our healthcare facilities.

Infection prevention and control is deservedly high on the agenda for healthcare workers, patients and stake holders in reducing healthcare-associated infections. The battle against infectious microbes will never end, and infection control will always be at the centre of all Medicine. Thus, we have to constantly work towards new ways to win this battle.

This revised edition is intended to be used as a reference for healthcare professionals, management and operations staff to ensure protocols and procedures are adhered to. When appropriately adapted and in place, we can aim to reduce the risk of healthcare associated infections. It is my fervent hope that everyone in the healthcare industry will work hand-in-hand to optimise infection prevention and control practices, standardize them in order to reduce any variations and use this as a guide for quality improvement in all Ministry of Health hospitals in the country.

As Brian Tracy, a Canadian-American motivational public speaker once said and I quote, "You cannot control what happens to you, but you can control your attitude towards what happens to you, and in that, you will be mastering change rather than allowing it to master you". Together, we can master these changes for a safer healthcare system in Malaysia.

Thank you

A handwritten signature in black ink, appearing to read 'Hisham', written over a white background.

Datuk Dr. Noor Hisham bin Abdullah

FOREWORD
**BY THE DEPUTY DIRECTOR-GENERAL OF
HEALTH (MEDICAL), MINISTRY OF HEALTH,
MALAYSIA**



Infection Control remains a major issue in Malaysia and the reason for this is we are fighting a battle against invisible enemies; the microbes. This battle is far more challenging and arduous as compared to a straight forward war field battle. Infection Prevention and Control undisputedly plays a major role in reducing healthcare associated infections (HCAI). Globally, HCAI affects millions of patients every year. HCAI leads to serious illnesses, prolonged hospital stays, causes long term disabilities, loss of life and brings on higher cost for the patients and families. Not only is it a problem for the patient, but from the point of view of the healthcare system, it becomes a financial burden in terms of bed occupancy as well usage of multiple resources in an attempt to treat this HCAI.

Increased healthcare associated infection has been linked to an increase in antimicrobial resistance (AMR). AMR has been identified as a major health threat globally and Malaysia has not been spared. Because of antimicrobial resistance, many infections are no longer easily treated, leading to prolonged illness and greater risk of death for patients. In addition, the cost of healthcare escalates because expensive antibiotics are used for a longer duration in order to treat these infections.

This revised National Infection Prevention and Control Policies and Procedures from the previous edition in 2010 should be used as reference and guidance by healthcare workers in their daily work within healthcare facilities. It will help in strengthening infection control practices, preventing healthcare associated infections and limiting spread of AMR. Joint efforts among healthcare workers in our healthcare system will make the difference to the health of Malaysian.

Thank you

A handwritten signature in black ink, appearing to read 'Rohaizat bin Hj Yon'. The signature is stylized and fluid.

Datuk Dr. Hj Rohaizat bin Hj Yon



ADVISORS

YBhg Datuk Dr. Noor Hisham bin Abdullah
Director-General of Health Malaysia

YBhg Datuk Dr. Hj Rohaizat bin Hj Yon
Deputy Director-General of Health Malaysia (Medical)

YBhg Dato' Dr. Hj Bahari bin Dato' Tok Muda Awang Ngah
Director, Medical Development Division

Dr. Paa Mohamed Nazir bin Abdul Rahman
Deputy Director, Medical Care Quality Section

GUIDELINE COMMITTEE MEMBERS

Datuk Dr. Christopher Lee
Dato' Dr. Mahiran Mustafa
Dr. Nurahan Maning
Dr. Suraya Amir Husin
Dr. Tuan Suhaila Tuan Soh
Dr. Yasmin Mohamed Gani
Dr. Cheng Joo Thye
Dr. Petrick Periyasamy

Dr. Leong Chee Loon
Dr. Ahmad Shaltut Othman
Dr. Benedict Lim Sim
Dr. Zubaidah Abdul Wahab
Dr. Low Lee Lee
Dr. Zuraida Mohamed
Dr. Norlizam Mohd Nor

EDITORS

Dato' Dr. Mahiran Mustafa
Dr. Nurahan Maning
Dr. Suraya Amir Husin
Dr. Tuan Suhaila Tuan Soh
Dr. Yasmin Mohamed Gani
Dr. Ahmad Shaltut Othman
Dr. Azraai Bahari Nasrudin
Dr. Cheng Joo Thye
Dr. Hazilawati Hussain
Dr. Rohaidah Hashim
Prof Dr. Ariza Adnan
Dr. Petrick Periyasamy
Dr. Zawaniah Brukan Ali
Dr. Zubaidah Abdul Wahab
Dr. Fong Siew Moy
Dr. Zuraida Mohamed

SECRETARIAT

Medical Care Quality Section, Medical
Development Division, Ministry of Health

Dr. Paa Mohamed Nazir Abdul Rahman
Dr. Suraya Amir Husin
Dr. Puteri Fajariah Megat Mohd Ghazali
Dr. Nor Farah Bakhtiar
Dr. Affaf Azizan
Dr. Noor Amelia Abd Rasid
Dr. Zawaniah Brukan Ali
Dr. Sara Sofia Yahya
Puan Suhaily Othman
Puan Norhanida Shariffudin
Puan Siti Hawa Sa'adun

LIST OF CONTRIBUTORS

IPC GOVERNANCE

Datuk Dr. Christopher Lee
Dr. Suraya Amir Husin
Dr. Noor Amelia Abd Rasid
Pn. Rohana Omar

SURVEILLANCE & AUDIT

Dr. Tuan Suhaila Tuan Soh
Dr. Puteri Fajariah Megat Mohd Ghazali
Pn. Siti Hawa Sa'adun

FUNDAMENTAL PRINCIPLES OF INFECTION PREVENTION

Dr. Yasmin Mohamed Gani
Dr. Hazilawati Hussin
Dr. Rosnaida Mohd Noh
Dr. Nor Farah Bakhtiar
En. Amir Ikram Muhammad
En. Alif Riduan Khalid@Othman
Pn. Zairul Ain Zulkafli
Pn. Suhaily Othman
Pn. Nor Yatimah Wahab
Pn. Marina Idi

ISOLATION ROOM / AREA

Dr. Cheng Joo Thye
Dr. Leong Kar Nim
Ir. Rosmahadi Ali
En. Mohd Amirul Fahmi Mohd Lazim
Pn. Nora Misran

CLINICAL PRACTICE

Dr. Petrick Periyasamy
Dr. Afifah Haji Hassan
Dr. Noraishah Md Rani
Pn. Farizan Abdul Ghaffar
Pn. Harizah Dato' Mohd Yaacob

PREVENTION OF HCAI

Dr. Leong Chee Loon
Dr. Ahmad Shaltut Othman
Dr. Norlizam Mohd Nor
Pn. Elly Ismail

INFECTION CONTROL IN SPECIFIC HEALTHCARE SETTING

Dr. Ahmad Shaltut Othman
Dr. Shahnaz Shah Firdaus Khan
Ir. Rosmahadi Ali
En. Mohd Kamalluddin Hashim
Pn. Ang Sin Yin
Dr. Cheng Lai Choo
Pn. Mageswary Lapchmanan
Pn. Akmawati Daud @Abd. Razak
Dr. Chew Lee Ping
Dr. Suhaila Md Hanapiah
Dr. Mohd Suhani Moh Noor
Dr. Khairul Zainun Bahrin

Miss (Dr) Salmi Mohamed Sukur
Pn. Baljit Kaur a/p Amir Singh
Pn. Zalimah Tukimin

ANTIMICROBIAL RESISTANCE (AMR)

Dr. Benedict Lim Sim
Dr. Suraya Amir Husin
Dr. Syamhanin Adnan
Dr. Rohaidah Hashim
Pn. Hazimah Hashim
Pn. Mardhiyah Kamal

SPECIFIC ORGANISMS OF CLINICAL INTEREST

Dr. Zubaidah Abdul Wahab
Dr. Ismaliza Ismail
Dr. Lailatul Akmar Mat Nor

HOSPITAL OUTBREAK MANAGEMENT

Dr. Low Lee Lee
Prof. Dr. Ariza Adnan
Dr. Affaf Azizan
Pn. Zohara Amin

OCCUPATIONAL SAFETY & HEALTH FOR HCW

Dr. Zuraida Mohamed
Dr. Sirajuddin Hashim
Dr. Anuradha P Radhakrishnan
Dr. Siti Sara Yaacob

ENVIRONMENTAL

Dr. Norlizam Mohd Nor
Dr. Nurahan Maning
Pn. Nurul Aini Mat Sot
En. Voon Kok How
En. Zulfilmie Amran
Pn. Bariah Bakri
Pn. Nor'Ain Abdul Manan

STERILISATION & DISINFECTION

Dr. Fong Siew Moy
Dr. Nurzam Suhaila Che Hussin
Ir. Suhaimi Rashid
En. Mohd Kamalluddin Hashim
Pn. Mek Jusoh
Pn. Inna Lamin
Pn. Surayah Suboh

COMMUNICATION & SHARING/ EDUCATION & TRAINING

Dr. Yasmin Mohamed Gani
Dr. Hazilawati Hussin
Dr. Rosnaida Mohd Noh
Dr. Nor Farah Bakhtiar
En. Amir Ikram Muhammad
En. Alif Riduan Khalid@Othman
Pn. Suhaily Othman
Pn. Nor Yatimah Wahab
Pn. Marina Idi

ABBREVIATIONS

ABHR	Alcohol Based Hand Rub
ACH	Air Change Per Hour
AHU	Air Handling Unit
AIIR	Airborne Infection Isolation Room
AMR	Antimicrobial Resistance
AMS	Antimicrobial Stewardship
AST	Antibiotic Susceptibility Test
BAL	Bronchoalveolar Lavage
BBP	Blood Borne Pathogens
BEMS	Biomedical Engineering Maintenance Services
BP	Blood Pressure
BSI	Blood Stream Infection
CAUTI	Catheter Associated Urinary Tract Infection
CDC	Centers for Disease Control and Prevention
CDR	Cytotoxic Drug Reconstitution
CSSD	Central Sterile Supplies Department
CFU	Colony Forming Unit
CLS	Cleansing Services
CPD	Continuous Professional Development
CRBSI	Catheter Related Blood Stream Infection
CRE	Carbapenem-Resistant <i>Enterobacteriaceae</i>
CVC	Central Venous Catheter
DIACC	District Infection and Antibiotic Control Committee
ESBL	Extended Spectrum Beta-Lactamase
FEMS	Facility Engineering Maintenance Services
FFR	Filtering Facepiece Respirator
FIFO	First In First Out
FMS	Family Medicine Specialist
GI	Gastrointestinal

GPP	Good Preparation Practice
GvHD	Graft versus Host Disease
HABSI	Healthcare Associated Blood Stream Infection
HAMDRO	Healthcare Associated Multidrug Resistance Organism
HAP	Hospital Acquired Pneumonia
HBV	Hepatitis B Virus
HCP	Healthcare Personnel
HCAI	Healthcare Associated Infection
HCAP	Healthcare Associated Pneumonia
HCV	Hepatitis C Virus
HCW	Healthcare Workers
HDU	Haemodialysis Unit
HEPA	High Efficiency Particulate Air
HH	Hand Hygiene
HIACC	Hospital Infection and Antibiotic Control Committee
HIV	Human Immunodeficiency Virus
HSS	Hospital Support Service
HSV	Herpes Simplex Virus
HVAC system	Heating, Ventilation and Air-Conditioning System
HWMS	Healthcare Waste Management Services
IC	Infection Control
ICD	Infection Control Doctor
ICLN	Infection Control Link Doctor
ICN	Infection Control Nurse
ICRA	Infection Control Risk Assessment
ICU	Intensive Care Unit
IPC	Infection Prevention and Control
LEV	Local Exhaust Ventilation
LLS	Linen and Laundry Services
MDRO	Multidrug Resistance Organism
MERS-CoV	Middle East Respiratory Syndrome Coronavirus
MinDef	Ministry of Defence
MLN	Mesenteric Lymph Node
MOH	Ministry of Health

MOHE	Ministry of Higher Education
MRSA	Methicillin Resistant <i>Staphylococcus aureus</i>
MRSAB	Methicillin Resistant <i>Staphylococcus aureus</i> Bacteremia
NIACC	National Infection and Antibiotic Control Committee
NICU	Neonatal Intensive Care Unit
NSAR	National Surveillance of Antimicrobial Resistance
OHCW	Oral Healthcare Workers
OMF	Oral and Maxillofacial
OMT	Outbreak Management Team
OSHA	Occupational Safety and Health Administration
OT	Operation Theatre
PAPR	Powered Air Purifying Respirator
PD	Peritoneal Dialysis
PICC	Peripherally Inserted Central Catheter
POG	Project Operational Guidelines
PN	Parenteral Nutrition
PPE	Personal Protective Equipment
PPM	Plan Preventive Maintenance
PPS	Point Prevalence Survey
RO	Reverse Osmosis
RSV	Respiratory Syncytial Virus
SARS	Severe Acute Respiratory Syndrome
SIACC	State Infection and Antibiotic Control Committee
SSI	Surgical Site Infection
TB	Tuberculosis
TPN	Total Parenteral Nutrition
UCV	Ultra Clean Ventilated
UVGI	Ultraviolet Germicidal Irradiation
UNICEF	United Nations International Children's Emergency Fund
UTI	Urinary Tract Infection
VAP	Ventilator Acquired Pneumonia
VRE	Vancomycin-Resistant Enterococci
WHO	World Health Organization

1

INFECTION PREVENTION AND CONTROL GOVERNANCE

1.1 Introduction

Infection prevention and control practices are important in maintaining a safe environment for patients by reducing the risk of the potential spread of disease from person to person. Addressing infection prevention and control requires a facility-wide programme and should be a priority in every healthcare institution, thus, infection control governance plays an integral role in patient healthcare. In Malaysia, infection prevention and control governance consists of multi-tier committees which oversee and coordinate the IPC at different levels. The levels are as follows:

1. National Infection and Antibiotic Control Committee (NIACC)
2. State Infection and Antibiotic Control Committee (SIACC)
3. Hospital Infection and Antibiotic Control Committee (HIACC)
4. District Infection and Antibiotic Control Committee (DIACC)

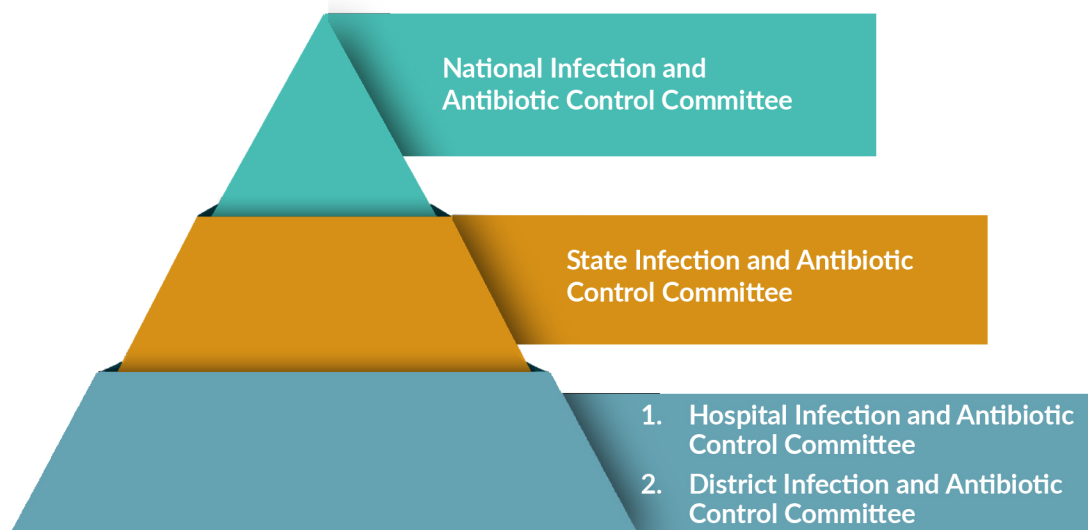

1.2 National Infection and Antibiotic Control Committee (NIACC)

A. Introduction to NIACC

The National Infection and Antibiotic Control Committee (NIACC) is a governance body essential for coordinating national efforts in reducing and preventing healthcare associated infection (HCAI) as well as to promote judicious use of antimicrobials to control antimicrobial resistance (AMR). The NIACC involves participation from Ministry of Health and University Hospitals.

B. Functions of NIACC

1. NIACC is responsible for developing policies and procedures related to infection control, AMR and antibiotic usage in Ministry of Health, Malaysia.
2. The Committee will act as the source of expertise on matters relating to infection control, AMR and antibiotic usage.
3. The Committee reviews issues related to infection control, AMR and antibiotic use and advises the Chairman of the Infection Control and Antibiotic Committee at the State level including the Hospital Director and related Head of Division.
4. Issues in this meeting will be brought up in the National Antimicrobial Resistance Committee.

C. Scope

The NIACC addresses all infection prevention and antibiotic control activities involving both Ministry of Health healthcare facilities and University Hospitals under the Ministry of Education.

D. Terms of Reference

1. Information sharing

The NIACC provides a structure for information sharing to mutually reinforce activities among sectors in MOH and University Hospitals.

2. Interactions

The NIACC will interact with the health system, public health and disease-specific programmes. The members of the NIACC is well represented and

they have clearly defined roles and responsibilities in the existing health system, public health and disease-specific programmes.

3. Membership

The duration of appointment is for two years.

a. Composition of National Infection and Antibiotic Control Committee

The following will be members of the NIACC:

1. Director General of Health, Ministry of Health - Chairman
2. Senior Director of Pharmaceutical Services, Ministry of Health
3. Principal Director of Oral Health, Ministry of Health
4. Director of Medical Development Division, Ministry of Health
5. Director of Diseases Control Division, Ministry of Health
6. Head of Infectious Disease Service, Ministry of Health
7. Head of Clinical Microbiology Service, Ministry of Health
8. Director of Pharmacy Practice & Development Division, Ministry of Health
9. Director of Engineering Services Division, Ministry of Health
10. Director of Nursing Division, Ministry of Health
11. Director of Family Health Development Division, Ministry of Health
12. Deputy Director of Pharmacy Practice & Development Division, Ministry of Health – Secretary
13. Deputy Director of Medical Development Division, Ministry of Health
14. Head of Infectious Disease Research Centre, IMR, Ministry of Health
15. Head of Bacteriological Unit, IMR, Ministry of Health
16. Head of Infection Control Unit, Medical Development Division, Ministry of Health
17. Head of Infection Control Unit, Family Health Development Division, Ministry of Health
18. Head of Occupational Safety and Health Unit, Disease Control Division, Ministry of Health
19. Head of Occupational Safety and Health Unit, Medical Development Division, Ministry of Health
20. Coordinator of State Infection & Antibiotic Control Committee (13 states + 1 federal)
21. Chairman of Antibiotic Working Committee, Pharmacy Practice and Development Division, Ministry of Health
22. Head of Infection Control Department/Unit University Malaya Medical Centre

23. Head of Infection Control Department/Unit the National University Malaysia Medical Centre
24. Head of Infection Control Department/Unit Malaysia Science University Medical Centre
25. Family Medicine Specialist Representative from Ministry of Health
26. Clinical Experts from Identified Institutions

b. Roles and Responsibilities

i. Chairman

The committee will be chaired by DG of Health and the chairman will:

- Lead facilitation and coordination of the national infection and antibiotic control activities.
- Provide a platform for programme planning and implementation
- Chair the NIACC meetings.
- Review and approve NIACC output.
- In the absence of the Chairman, the meeting will be chaired by a member assigned by the Chairman.

ii. Members of National Infection and Antibiotic Control Committee

- Participate in the annual NIACC meeting.
- Provide technical input.
- Report to the chairman and committee on the progress of the activities, non-achievable targets as well as propose on actions to be taken.

iii. Secretariat of National Infection and Antibiotic Control Committee

- Pharmacy Practice & Development Division will act as the main secretariat.
- Schedule and prepare the agenda of annual NIACC meetings.
- Preparation of NIACC documents, reports and minutes of meetings as appropriate.
- Maintain a spreadsheet to track progress on recommendations.
- Facilitate NIACC correspondence.

4. Meeting Format for National Infection and Antibiotic Control Committee

a. Frequency of Meetings

- Meetings shall be held at least once a year.

- Members of the committee shall be notified of the date and agenda of meeting at least two weeks prior to the meeting.
 - Minutes should be kept and ratified.
- b. Agenda of the meetings
- Agenda of the meeting should include:
- Report on the incidence and prevalence of MDRO organisms and emerging resistant organisms
 - Report on National Surveillance of Antibiotic Resistance
 - Report on Antimicrobial Resistance Containment activities
 - Report on Healthcare Associated Infection Surveillance
 - Report on Antibiotic Utilization Surveillance
 - Report on Tuberculosis Surveillance among Healthcare Workers
 - Report on Sharp Injuries among Healthcare Workers
- c. Quorum
- The quorum of meeting shall consist of at least two thirds of the committee members.
 - If a vote is warranted on any issue, a simple majority will be required.
- d. Meetings on Outbreak Management
- The Chairman shall call for an urgent meeting and members will be notified accordingly.
 - Meetings are arranged for the control of outbreaks that may pose public health threats. (Refer to Chapter 10: Hospital Outbreak Management)
 - Other personnel may be invited if deemed necessary

1.3 State Infection and Antibiotic Control Committee (SIACC)

A. Introduction

The SIACC is a governance body essential for coordinating state efforts in reducing and preventing healthcare associated infection (HCAI) as well as to promote judicious use of antimicrobials to control AMR. The SIACC involves a multi-disciplinary participation from State Health Department, hospitals and primary health care facilities.

B. Functions

1. SIACC will provide expertise on matters related to infection control and antibiotic usage.
2. Preparation and submission of report to NIACC.
3. The Committee reviews issues related to infection control and antibiotic use and advises the Infection Control Doctor (ICD) or Infection Control Nurse (ICN) at the health care facilities level through the Hospital Director or District Health Officer.
4. Identified issues from this meeting will be raised at the NIACC meeting.

C. Scope

The SIACC addresses all infection prevention and antibiotic control activities involving both hospitals and primary healthcare facilities of MOH.

D. Terms of Reference

1. Information sharing

SIACC provides a platform for information sharing and to facilitate activities involving both hospitals and primary healthcare facilities of MOH.

2. Interactions

SIACC will coordinate and monitor infection and antibiotic control activities of both hospitals and primary healthcare.

3. Membership

The duration of appointment is for two years.

a. Composition of State Infection and Antibiotic Control Committee

The following will be members of the SIACC:

1. State Health Director – Chairman
2. Deputy State Health Director (Medical)
3. Deputy State Health Director (Public Health)
4. Deputy State Health Director (Dental)
5. Deputy State Health Director (Pharmacy)
6. State Infection Control Doctor (ICD) Coordinator
7. Officer In-charge of Hospital Quality Section of State Health Department

8. Officer In-charge of Primary Health Care in State Health Department
9. Officer In-charge of Dental Primary Health Care
10. Occupational Safety and Health Officer (Environmental and Occupational Health)
11. State Epidemiologist
12. State Engineer
13. State Nursing Matron
14. State Assistant Medical Officer
15. State Infection Control Nurse (ICN) Coordinator
16. Chairman of Infection & Antibiotic Control Committee from all hospitals in the state
17. State Clinical Microbiologist
18. State Family Medicine Specialist
19. Representative of Dentist from Hospital
20. Representative of Regional Public Health Laboratory
21. Representative in State Drug Committee
22. Representative of Pharmacist from Primary Health Care
23. Representative of Link Personnel from Primary Health Care
24. State Surgeon
25. State Physician
26. State Anaesthesiologist
27. State Paediatrician
28. State AMS Champion

b. Roles and Responsibilities

i. Chairman

The State Health Director shall be the chairman and will:

- Chair the SIACC meetings
- Facilitate and coordinate the state infection prevention and antibiotic control activities
- Review and approve SIACC output
- In the absence of the Chairman, the meeting will be chaired by a delegate assigned by the chairman.

ii. State Infection Control Coordinator

- Represent the state at NIACC meeting.
- Assist the Chairman in facilitation and coordination of the state infection prevention and antibiotic control activities



- Prepare the infection prevention and antibiotic control report.
- Advise the chairman and committee on actions to be taken if national performance indicators are not met (as set by NIACC) or any issues that requires interventions.

iii. Head of Public Health Team

The Family Medicine Specialist (FMS) shall be appointed as the head of the Public Health Team

- Prepare report on infection prevention and antibiotic control performance for Primary Health Care
- Advise the chairman and committee on actions to be taken if national performance indicators are not met (as set by NIACC) and any issues that requires interventions.

iv. Members of State Infection and Antibiotic Control Committee

- Participate in the biannual SIACC meeting.
- Provide technical advice on implementation of activities.

v. Secretariat of State Infection and Antibiotic Control Committee

The Head of the Secretariat will be appointed by the State Health Director with the advice from the State IC Coordinator.

- Schedule and prepare the agenda of biannual meetings of SIACC.
- Prepare the documents, reports and minutes of SIACC meetings.
- Maintain a spreadsheet to track progress on recommendations
- Facilitate SIACC correspondence

4. Meeting Format for State Infection Control and Antibiotic Committee

a. Frequency of Meetings

- Meetings shall be held at least twice a year.
- Members of the committee shall be notified of the date and agenda of meeting at least two weeks prior to the meeting.
- Minutes should be kept and ratified.

b. Agenda of the meetings

Agenda of the meeting should include:

- Report on the incidence and prevalence of MDRO organisms and/or emerging resistant organisms
- Report on State Surveillance of Antibiotic Resistance (Hospital and Primary HealthCare)

- Report on Healthcare Associated Infection Surveillance
 - Report on Antibiotic Utilization Surveillance (Hospital and Primary Health Care)
 - Report on Sharp Injuries among Healthcare Workers (Hospital and Primary Health Care)
 - Report on Tuberculosis among Healthcare Workers (Hospital and Primary Health Care)
- c. Quorum
- The quorum of meeting shall consist of at least two third of the committee members.
- d. Emergency Meetings on Outbreak Control
- The Chairman shall call for an urgent meeting and members will be notified accordingly.
 - Meetings are arranged for the control of outbreaks that may pose public health threats. (Refer to Chapter 10: Hospital Outbreak Management)
 - Other personnel may be invited if deemed necessary



Organization Chart State Infection and Antibiotic Control Committee (SIACC)

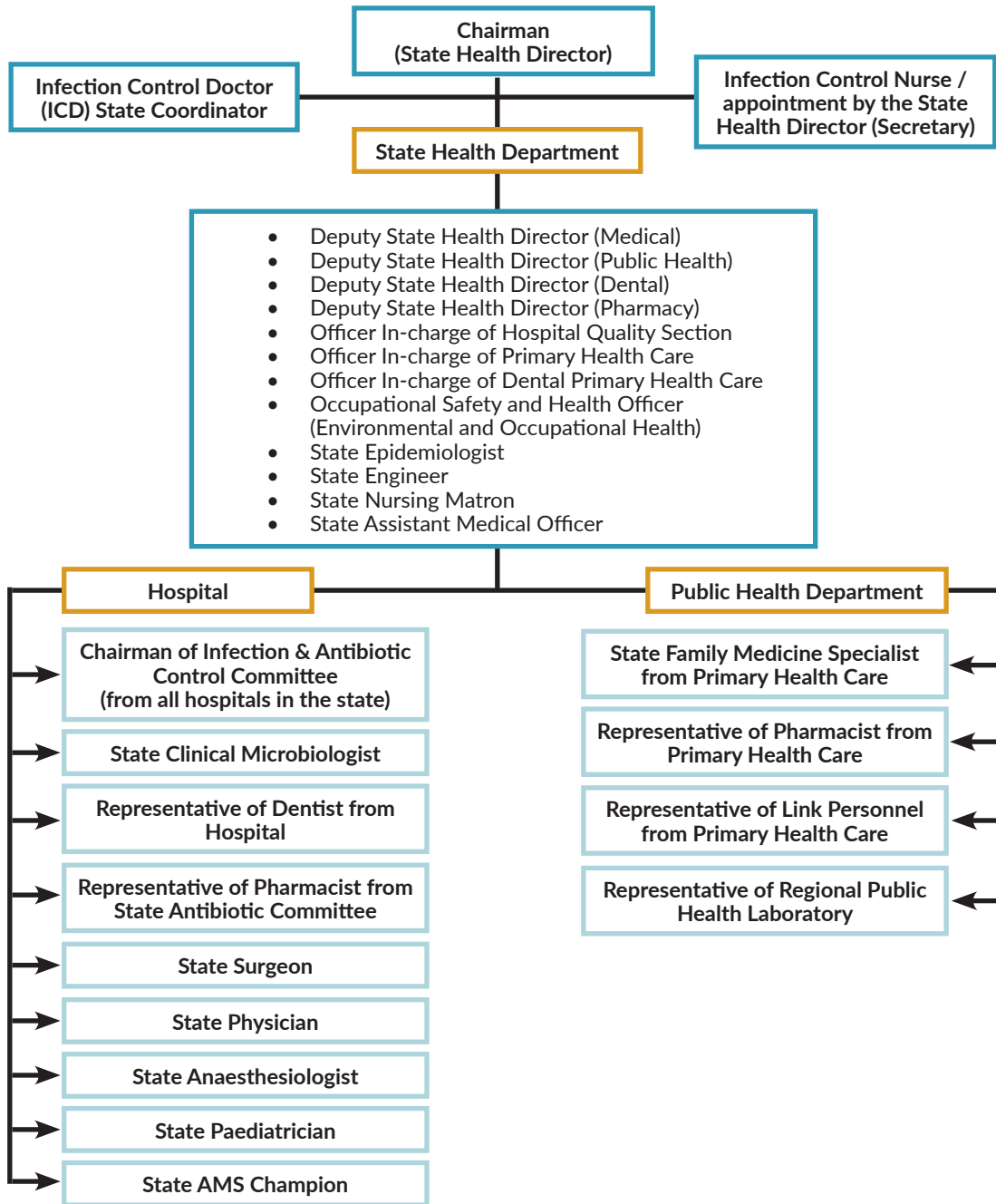

1.4 Hospital Infection and Antibiotic Control Committee (HIACC)

A. Introduction

The Hospital Infection and Antibiotic Control Committee (HIACC) functions as a governance body to coordinate hospital activities in prevention and control of HCAI, promote judicious use of antimicrobials and control the emergence of AMR. The HIACC involves a multi-disciplinary participation from various departments and units.

B. Functions

1. The HIACC is responsible in developing policies and procedures related to infection control, AMR and antibiotics usage in the hospital.
2. HIACC will provide expertise on matters related to infection control and antibiotic usage.
3. Preparation and submission of report to SIACC.
4. The Committee reviews issues related to infection control and antibiotic use and advises the healthcare workers through the Head of Department / Unit.
5. Identified issues from this meeting will be raised at the SIACC meeting.

C. Scope

The HIACC addresses all infection prevention and antibiotic control activities in its respective hospital.

D. Terms of Reference

1. Information sharing

The HIACC provides a structure for information sharing to mutually reinforce activities among departments in the hospitals.

2. Interactions

The HIACC will interact with the health system, public health and disease-specific programmes. Members of the HIACC are well represented and have clearly defined roles and responsibilities in existing health system, public health and disease-specific programmes.

3. Membership

Representatives should be given sufficient authority by their institution to make decisions.

a. Composition of Hospital Infection and Antibiotic Control Committee

The following will be members of the HIACC:

1. Hospital Director – Chairman
2. Hospital Infection Control Doctor/ Coordinator
3. Infection Control Unit – Secretariat
4. Hospital Deputy Director
5. Infectious Disease Physician and / or Paediatrician
6. Clinical Microbiologist / Science officer
7. Infection Control Nurse (by appointment)
8. Consultant Physician
9. Consultant Surgeon
10. Consultant Orthopaedic surgeon
11. Consultant Paediatrician
12. Consultant Anaesthesiologist/Intensives
13. Consultant Obstetrician
14. Consultant Oral Maxillofacial (OMF) / Dentistry
15. Pharmacist
16. Hospital Engineer
17. Medical officer of Hospital Infection Control Unit (by appointment)
18. Occupational Safety and Health Officer (Environmental and Occupational Health) / Senior Health Inspector in-charge of Public Health Unit
19. Hospital Nursing Matron
20. Head of Assistant Medical Officer
21. Hospital Support Services Concessionaire Manager
22. Nursing Matrons / Sisters of specific clinical areas (e.g. Critical care areas) when deemed necessary
23. Head of Dietetics when deemed necessary
24. Central Sterile Supplies Department (CSSD) Manager
25. Operation Theatre Nursing Matron / Sister when deemed necessary
26. Financial Manager when deemed necessary

b. Roles and Responsibilities

i. Chairman

The committee will be chaired by the Hospital Director and the chairman will:

- Chair the HIACC meetings
- Facilitate and coordinate the hospital infection prevention and antibiotic control activities
- Review and approve HIACC output

In the absence of the Chairman, the meeting will be chaired by a member assigned by the chairman.

ii. Infection Control Doctor (ICD) Coordinator

- The ICD will be appointed by the hospital director. An ICD should have appropriate training and experience in matters relating to infection and antibiotic control. An ICD should possess good communication skills and leadership qualities.
- Represent the hospital at SIACC meetings.
- Assist the Chairman in facilitation and coordination of the hospital infection prevention and antibiotic control activities
- Lead the hospital level infection prevention and antibiotic control activities.
- Prepare the infection prevention and antibiotic control report
- Advise the Chairman and Committee on actions to be taken if national performance indicators are not met (as set by NIACC)

iii. The Secretariat of Hospital Infection and Antibiotic Control Committee

- Infection Control Unit will act as a secretariat.
- Schedule and prepare the agenda of each HIACC meeting
- Preparation of HIACC documents, reports and minutes of meetings as appropriate.
- Maintain a spreadsheet to track progress on recommendations
- Facilitate HIACC correspondence

iv. Members of Hospital Infection Control and Antibiotic Committee

- Participate in each HIACC meeting.
- Provide technical input.
- Representative from the department must be senior personnel



and should be replaced by a permanent alternate if the main representative is unable to attend the meeting.

4. Meeting Format for Hospital Infection Control and Antibiotic Committee

- a. Frequency of Meetings
 - Meetings shall be held at least twice a year.
 - Members of the committee shall be notified of the date and agenda of meeting at least two weeks prior to the meeting.
 - Minutes should be kept and ratified.
- b. Agenda of the meetings

Agenda of the meeting should include:

 - Report on the incidence and prevalence of MDRO organisms and/or emerging resistant organisms
 - Report on hospital Surveillance of Antibiotic Resistance
 - Report on Healthcare Associated Infection Surveillance
 - Report on Antibiotic Utilization Surveillance
 - Report on Infection Prevention and Control Audit
 - Report on Hand Hygiene Compliance Surveillance
 - Report on Sharp Injuries among Healthcare Worker
 - Report on Tuberculosis among Healthcare Worker
 - Report on outbreak and action plan.
- c. Quorum
 - The quorum of meeting shall consist of at least 2/3 of the committee members.
- d. Emergency Meetings And Outbreak Control
 - The Chairman may convene an emergency meeting of the Infection Control Committee at any time and all members or their representatives will be notified accordingly.
 - Emergency meetings are arranged for the control of outbreaks of infection and when the Infection Control Team requires additional support and notification of the problem in accordance with the major outbreak policy.
 - The Chairman will chair all emergency meetings and be in-charge of the technical aspect of the outbreak control measures.

Organization Chart Hospital Infection and Antibiotic Control Committee (HIACC)

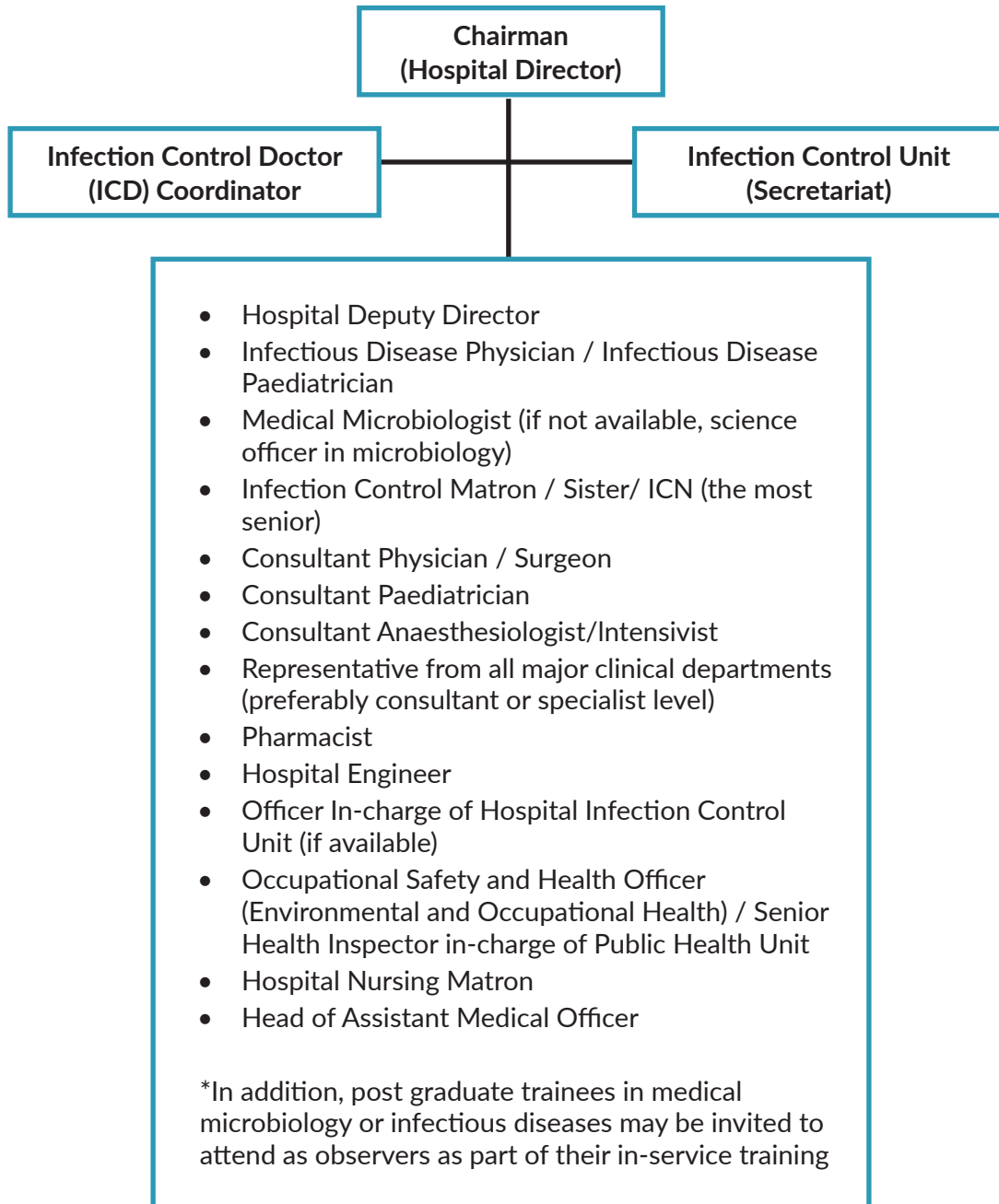

1.5 Infection Control Unit/Team

1. Head of IC unit/team is a clinician appointed by the hospital director.
2. The infection control nurse/personnel are full-time member of the hospital's infection control team.
3. The ratio of ICN/personnel to the hospital beds should conform to the MOH norm of 1:110

Duties and responsibilities of the Infection Control Team Members (Head of IC unit/team and Infection Control Nurse/ Personnel)

Clinical duties

1. Work closely with other members of HIACC and IC team.
2. Supervise and advise on infection prevention and control policies.
3. Provide clinical advice and support to HCW on infection control issues.
4. Ascertain the clinical significance of laboratory results of MDROs or possibility of an outbreak.
5. Provide clinical advice and support to HCW and other related external agencies.
6. Provide guidance and support to the infection control link nurse.

Surveillance

1. Coordinate surveillance activities for the hospital
2. Collect relevant information on behalf of the Infection Control Team including point prevalence studies on HCAI, antibiotic audits, hand hygiene compliance etc.

Coordination / organization of infection control activities

1. Identify potential infectious hazards and suggest appropriate remedial action to relevant personnel.
2. Recognize, investigate and implement immediate control measures during outbreaks.
3. Collaborate with the Infection Control Team and clinicians on the routine monitoring of critical care units.

Administrative

1. Participate in the development and implementation of the infection control policies.
2. Monitor compliance with infection control policies, including activities directly related to the audits
3. Prepare reports within a specified period.

Education

1. Participate in teaching programmes for all HCWs.
2. Keep abreast with recent advances by reading relevant literature and attending appropriate courses, meetings and exhibitions.
3. Advise staff with regards to the microbiologic hazards in occupational health safety and related issues in infection control.
4. Participate and coordinate infection control related educational campaigns.

Research and Quality Improvement Activities

1. Participate in research projects that are related to hospital infection.
2. Perform clinical audit/quality improvement projects on infection control activities and to evaluate its effectiveness.

1.6 Infection Control Link Nurse (ICLN)

1. The ICLN is an appointed nurse in each ward with sufficient nursing experience preferably in infection control.
2. The role as a link nurse is alongside other ward duties.
3. The ICLN acts as a liaison personnel between the HCWs in the ward and the Infection Control Team on matters related to infection control.

Duties and Responsibilities of ICLN

Supervision on infection control practices which include:

1. Ensure hand hygiene is being practiced in the ward
2. Ensure compliance with aseptic technique
3. Ensure compliance with PPE
4. Proper cleansing and sterilisation according to standard procedures



5. Proper storage of sterile instruments and linen
6. Proper collection and dispatch of specimens
7. Proper segregation and disposal of healthcare waste
8. Isolation of patients in accordance to transmission-based precautions
9. Advise on immediate management of sharp injuries

Surveillance

1. Participate in national surveillance and audit activities.
2. Assist in the prevention and reporting of sharp injuries among HCWs
3. Assist in notification of outbreaks

Education

1. Act as a resource personnel and advise on matters related to infection control.
2. Disseminate, educate and create awareness on infection control to HCWs in the ward.

1.7 Financial administration

The costs of the infection control program are part of the hospital's operational budget while hospital pharmacy shall manage the procurement and supply of all consumable items for infection control usage. Any unpredictable events such as outbreaks or hospital wide campaign activities shall also be borne by the hospital's operational budget.

2

HEALTHCARE ASSOCIATED INFECTION SURVEILLANCE

Introduction

Surveillance is one of the most important components of an effective infection control program. It is defined as the systematic collection, analysis, interpretation, and dissemination of data of HCAs in a definite patient population.

2.1 Purpose of Surveillance

1. To establish and maintain a database describing endemic rates of HCAs. Once endemic rates are known then the occurrence of an epidemic can be detected when infection rates exceed baseline values.
2. To identify trends manifested over a period, such as shifts in microbial pathogen spectrum, infection rates, etc.
3. To provide continuous observation of HCAI cases for the purpose of prevention and control.
4. To obtain useful information for establishing priorities for infection control activities.
5. To quantitatively evaluate control measures' effectiveness for a definite hospital population.
6. To enhance the role and authority of the infection control team in the hospital through participation in ward rounds, consultations and education of healthcare worker.

2.2 Main Components of Surveillance System

2.2.1 Definition of HCAI

Healthcare associated infections are infections that patients acquire 48 or more hours after admission during the course of receiving treatment for other conditions within a healthcare setting (CDC).

2.2.2 Case Definition

Each case definition must be standardized and consistent. The case definition used nationwide will be that of CDC definitions.

(Please refer to 'Definitions of HCAI' developed by CDC).

2.2.3 Types of Surveillance

2.2.3.1 Surveillance and reporting (outcome)

- Healthcare Associated Infections (HCAI)
- Healthcare Associated Blood Stream Infection (HA-BSI)
- Healthcare Associated Multi Drug Resistance Organism (HA-MDRO) and Methicillin Resistant *Staphylococcus aureus* (MRSAB)

2.2.3.2 Surveillance and reporting (procedure)

- Hand Hygiene
- Central Venous Catheter Care Bundle Compliance Surveillance
- Urinary Catheter Care Bundle Surveillance

2.2.3.3 Audit

- Infection Prevention And Control Audit
- Hand hygiene self-assessment framework

2.2.3.4 Other surveillances

- Hospital Surveillances
- Targeted / "High risk" patients

Healthcare Associated Infections (HCAI)

The prevalence of hospital infections in Malaysia is being observed through the healthcare associated infections (HCAI) surveillance program. The HCAI is determined through a one day hospital wide Point Prevalence Survey (PPS) which is conducted twice a year involving 21 MOH hospitals and 3 university hospitals.

The common types of infections surveyed in this programme are urinary tract infection (UTI), surgical site infection (SSI), pneumonia, blood stream infection (BSI) and clinical sepsis.

(Please refer to Manual Point Prevalence Survey for Healthcare Associated Infection & Antibiotics, 3rd Edition 2019)

Primary Healthcare Associated Bloodstream Infection (HABSI)

Primary Healthcare Associated bloodstream infection (HABSI) represents about 15% of all nosocomial infections and affects approximately 1% of all hospitalized patients, with an incidence rate of 5 per 1,000 central-line days. Approximately 90% of primary BSIs occur in patients with intravascular devices, especially central lines.

BSI increases the mortality rate, prolongs patient stay in the hospital and generates substantial extra costs. For these reasons, surveillance and prevention of BSI are high priorities. One month- period prevalence survey is conducted twice a year nationwide.

(Please refer to Manual PPS for HA-BSI 2nd edition (2015) for methodology, case definition and data management for surveillance)

Healthcare Associated Multi Drug Resistance Organism (HAMDR) and Methicillin Resistant *Staphylococcus aureus* (MRSAB)

Multidrug resistance organism surveillance is the continuous active laboratory based monitoring of the incidence of specified organisms such as Methicillin Resistant *Staphylococcus aureus*, ESBL- *Escherichia coli*, ESBL *Klebsiella pneumoniae*, MDR *Acinetobacter baumannii* , Carbapenem Resistant *Enterobacteriaceae* and Vancomycin Resistant *Enterococcus* . All laboratories shall use a standard definition for identification and reporting of these organisms. This surveillance program measures both healthcare associated infection and colonisation attributed to the organism of interest.

(Please refer to Manual for MDRO & MRSAB surveillance 2nd edition (2017) for methodology, case definition and data management for surveillance)



Hand Hygiene (HH)

Hand hygiene is considered to be the primary measures necessary for reducing HCAI. “Save lives clean your hand” campaign launched by WHO in 2009 focuses on 5 moments for HH to protect HCW, patient and healthcare environment against the spread of pathogens thus reducing HCAI. Although the action of HH is simple, the lack of compliance among HCW continues to be a problem. Evaluation of HH practices is one of the important elements to improve HH compliance. One way of evaluating the practice is by doing audit. HH compliance audit is performed quarterly using the WHO-world alliance for patient safety.

Central Venous Catheter (CVC) Care Bundle Compliance Surveillance

Central Line Associated Blood Stream Infection (CLABSI) is an important healthcare associated infection in hospitals which cause high mortality and morbidity rates as well as increased healthcare costs. CVC care bundle has been proven to be effective in reducing the rate of infections.

Care bundles are described as groups of best practices with respect to a disease process that individually improves care but when applied together result in substantially greater improvement.

CVC care bundle consists of:

- Hand hygiene
- Maximal barrier precaution upon insertion
- Chlorhexidine skin antisepsis
- Optimal catheter site selection
- Daily review of line

One month- period prevalence survey is conducted twice a year nationwide.

(Please refer to Central Venous Catheter Care Bundle Compliance Surveillance manual (2016) for methodology, definitions and data management)

Urinary Catheter Care Bundle Surveillance

Urinary tract infection (UTI) is among the common types of HCAI and about 75% are associated with a urinary catheter. The most important risk factor for developing a catheter associated urinary tract infection (CAUTI) is prolonged use of the urinary catheter. Thus, catheters should only be used for appropriate indications and removed as soon as they are no longer needed.

Use of CAUTI bundle has been demonstrated to reduce the rate of UTI.

Urinary Catheter Care Bundle consists of:

- Indication for indwelling catheter
- Sterile technique for catheter insertion
- Maintain a sterile closed drainage system
- Position drainage bag below the level of the bladder at all times, including during transport
- Secure indwelling catheter to prevent movement and urethral traction
- Daily review for indication of continuation

Infection Prevention and Control Audit

Infection prevention and control programs are designed to prevent the spread of infection in healthcare settings. HCW compliance with infection control practices and principles is vital in preventing the spread of disease. Infection control audit can be used to assess infection control practice in healthcare facilities. It is conducted twice yearly nationwide.

(Please refer to Infection Prevention and Control Audit manual (2016) for methodology, definitions and data management)

Hand Hygiene Self-assessment Framework

This is a tool developed by WHO to analyse hand hygiene promotions and practices within an individual healthcare facility. It reflects existing resources and achievements thus helps to focus on future plans and challenges.

The framework consists of 5 components namely system change, training and education, evaluation and feedback, reminder in workplace and institutional safety



climate for hand hygiene. There are 27 indicators representing key elements for each component. Each indicator is formulated as questions with defined answers. Each answer is assigned a certain score. Based on the score achieved for 5 components, the facility is assigned to one of four levels of hand hygiene promotion and practice: inadequate, basic, intermediate and advanced.

(Please refer WHO Hand Hygiene Self-Assessment Framework 2010 for a complete description on how to use the assessment tool, scoring and interpretation)

Hospital Surveillances

Choice of types of surveillances depends on the requirements of the individual hospital and must be agreed by the Hospital Infection and Antibiotic Control Committee members.

Example:

SSI- surgical site infection by Surgical department

Targeted Patients in Special and Critical Care Area

The focus in this type of epidemiological surveillance is on patients at increased risk of nosocomial infections (e.g. post-surgical patients, ICU patients, and patients receiving mechanical ventilation). The denominator of the incidence rate formula should contain only data on patients belonging to the targeted group. Infection risk indices can and must be used.

This study permits concentration of effort on areas where infection control measures may have the greatest effect and better use of limited resources; taking into account differences in infection risk for different patient populations. However, this study may miss clusters or outbreaks of infections not included in the surveillance program.

Example: BSI, CVC care bundle in critical care (ICU, NICU & hospital dialysis centre)

3

FUNDAMENTAL PRINCIPLES OF INFECTION PREVENTION

A. STANDARD PRECAUTION

3.1 Hand Hygiene

Introduction

Hand Hygiene is a general term used to describe cleaning hands by using soap and water, antiseptic wash or by using an alcohol-based hand rub (ABHR) solution. Hand Hygiene is considered to be the single most important way to stop the spread of germs. If the hands of those caring for a patient, as well as the hands of the patient and their family/visitors, are kept clean, the risk of the patient getting an infection will be far less.

Performing Hand Hygiene

Hand hygiene ideally should be carried out at the **point of care**.

The point of care represents the time and place at which there is the highest likelihood of transmission of infection via healthcare staff, whose hands act as mediators in the transfer of microorganisms.

The point of care also refers to the patient's immediate environment in which healthcare staff-to-patient contact or treatment is taking place. In the hospital, the environment is usually at the patient's bed, but in the other context it could be in a treatment room, cot, chair, ambulance or a patient's home.

An alcohol-based hand rub (ABHR) is the preferred method for cleaning the hands when they are not visibly dirty because:

- It is more effective at killing potentially deadly germs on hands than soap
- It requires less time
- It is more accessible than hand washing sinks
- It reduces bacterial counts on hands, and
- It improves skin condition with less irritation and dryness compared to soap and water

Perform hand washing with plain or antimicrobial soap and water if:

- Hands are visibly soiled or dirty
- Caring for a patient with suspected or known gastrointestinal infection eg. *Norovirus* or a spore forming organism eg. *C.difficile*.

Avoid washing with hot water to prevent drying of skin.

Liquid soap from reusable containers must be cleaned regularly every 24 hours and dried before refilling with fresh soap to avoid microbial contamination. If the liquid soap reaches a minimum level, it needs to be changed and cleaned despite less than 24 hours.

Bar soap is not recommended as they can easily become contaminated. Gloves should not be regarded as a substitute for hand hygiene. An alcoholic rub or hand wash should be performed after removing gloves and before sterile gloves are worn.

Proper technique for decontamination of hands is probably of greater importance than the agent used. See figures for the technique of hand washing and antisepsis.

How to handrub?

RUB HANDS FOR HAND HYGIENE! WASH HANDS ONLY WHEN VISIBLY SOILED!

Duration of the entire procedure : 20-30 sec.



How to handwash?

WASH HANDS ONLY WHEN VISIBLY SOILED! OTHERWISE, USE HANDRUB!

Duration of the entire procedure : 40-60 sec.



*For the procedure involving the wrist (e.g palpation of the abdomen), additional step on rotational rubbing of right wrist clasped in left palm and vice versa should be included

Before performing hand hygiene:

- Expose forearms
- Remove all hand/wrist jewellery, watches
- Ensure finger nails are clean, short and artificial nail or nail products are not worn
- Cover all cuts or abrasions with water proof dressing

Your 5 Moments for Hand Hygiene

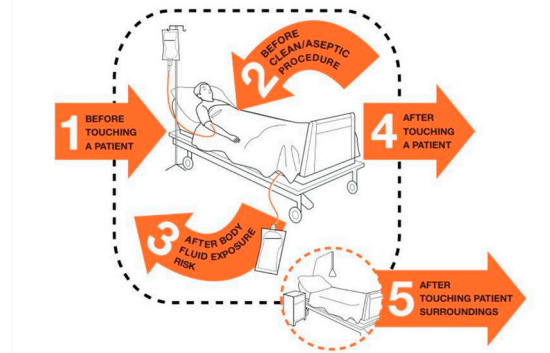

Five (5) moments in Hand Hygiene:

1. Before and after having direct contact with patients.
2. Before handling an invasive device for patient care, regardless of whether or not gloves are used.
3. After contact with body fluids or excretions, mucous membranes, non-intact skin, or wound dressings.
4. If moving from a contaminated body site to a clean body site during patient care.
5. After contact with inanimate objects (including medical equipment) in the immediate vicinity of the patient.

Surgical scrub

1. Remove rings, wrist-watch, and bracelets before beginning the surgical hand preparation
2. When performing surgical hand antisepsis using an antimicrobial soap, long scrub times are not necessary. Recommended duration is 2-3 minutes but not exceeding 6 minutes and should include wrists and forearms.
3. If hands are visibly soiled, wash hands with plain soap before surgical hand scrub.

Sterile disposable or auto-clavable nailbrushes may be used to clean the fingernails only, but not to scrub the hands. A brush should only be used for the first scrub of the day.

Surgical Handrubbing Technique

- Handwash with soap and water on arrival to OR, after having donned theatre clothing (cap/hat/bonnet and mask).
- Use an alcohol-based handrub (ABHR) product for surgical hand preparation, by carefully following the technique illustrated in Images 1 to 17, before every surgical procedure.
- If any residual talc or biological fluids are present when gloves are removed following the operation, handwash with soap and water.



1 Put approximately 5ml (3 doses) of ABHR in the palm of your left hand, using the elbow of your other arm to operate the dispenser.



2 Dip the fingertips of your right hand in the handrub to decontaminate under the nails (5 seconds).



3



4



5



6



7

Images 3-7: Smear the handrub on the right forearm up to the elbow. Ensure that the whole skin area is covered by using circular movements around the forearm until the handrub has fully evaporated (10-15 seconds).



8



9



10



11



12

Images 8-10: Now repeat steps 1-7 for the left hand and forearm.

Put approximately 5ml (3 doses) of ABHR in the palm of your left hand as illustrated, to rub both hands at the same time up to the wrists, following all steps in images 12-17 (20-30 seconds).

Cover the whole surface of the hands up to the wrist with ABHR, rubbing palm against palm with a rotating movement.



13

Rub the back of the left hand, including the wrist, moving the right palm back and forth, and vice-versa.



14

Rub palm against palm back and forth with fingers interlinked.



15

Rub the back of the fingers by holding them in the palm of the other hand with a sideways back and forth movement.



16

Rub the thumb of the left hand by rotating it in the clasped palm of the right hand and vice versa.



17

When the hands are dry, sterile surgical clothing and gloves can be donned.

Repeat this sequence (average 60 sec) the number of times that adds up to the total duration recommended by the ABHR manufacturer's instructions. This could be two or even three times.

Auditing hand hygiene compliance by health care providers shall follow the National Hand Hygiene Compliance Surveillance.

Areas Commonly Missed during Hand Washing

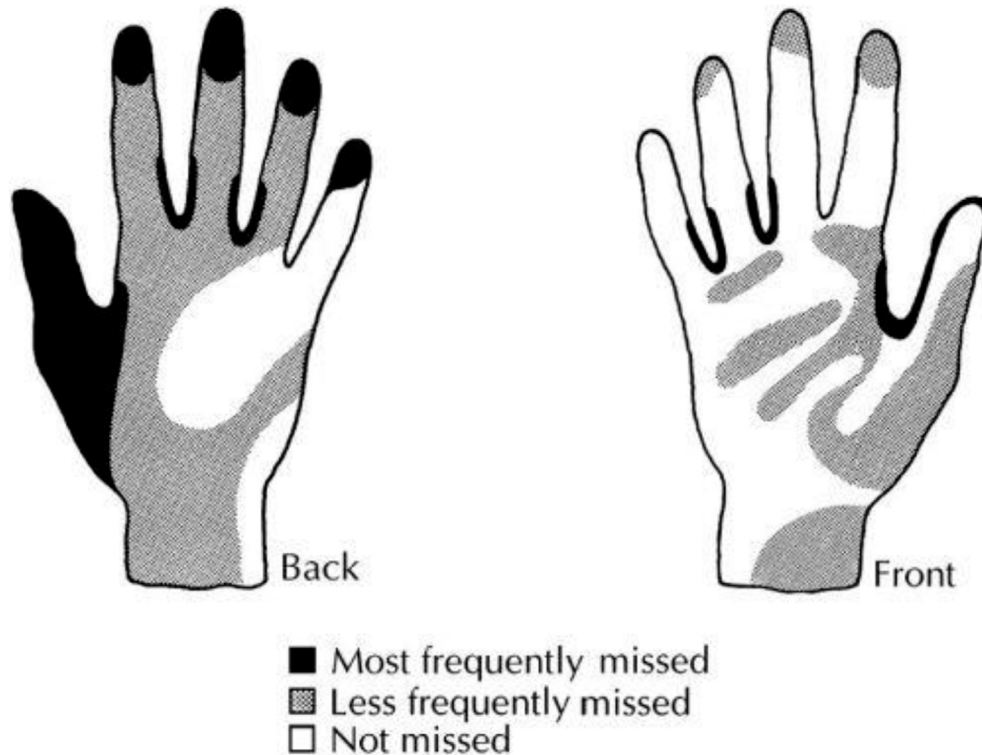

3.2 Personal Protective Equipment (PPE)

Personal protective equipment, commonly referred to as “PPE”, is equipment worn to minimise exposure to hazards that cause serious workplace injuries and illnesses. These injuries and illnesses may result from contact with chemical, radiological, physical, electrical, mechanical, or other workplace hazards. Personal protective equipment may include items such as gloves, safety glasses and shoes, earplugs or muffs, hard hats, respirators, or coveralls, vests and full body suits.

Recommendation by Occupational Safety and Health Administration (OSHA) United States

When selecting PPE, three key things need to be considered:

- **Type of anticipated exposure.** This is determined by the type of anticipated exposure, such as touch, splashes or sprays, or large volumes of blood or body fluids that might penetrate the clothing and by the category of isolation precautions a patient is on.
- **Durability and appropriateness of the PPE for the task.** Whether a gown or apron is more suitable. If a gown is selected, whether it needs to be fluid resistant, fluid proof, or neither.
- **Fit.** PPE must fit the individual user, and the employer should ensure that all PPE are available in sizes appropriate for the workforce that must be protected.

All PPE should be:

- Located close to the point of use;
- Stored to prevent contamination in a clean/dry area until required for use (expiry dates must be adhered to);
- Single use items unless specified by the manufacturer; and
- Disposed of after use into the correct waste stream i.e.. healthcare waste or domestic waste.

Reusable PPE items, e.g. non-disposable goggles/face shields/visors must have a decontamination schedule with responsibility assigned.

Gloves

Glove wearing by HCWs is recommended for two main reasons:

1. To prevent microorganisms which may be infecting, commensally carried, or transiently present on HCWs' hands from being transmitted to patients and from one patient to another; and
2. To reduce the risk of HCWs acquiring infections from patients.

Gloves must be:

- Worn when exposure to blood and/or other body fluids is anticipated/likely.
- Changed immediately after each patient and/or following completion of a procedure or task;
- Changed if a perforation or puncture is suspected; and
- Appropriate for use, fit for purpose and well-fitting to avoid excessive sweating and interference with task performance.

Limit opportunities for ‘touch contamination’

- Do not touch face area or adjust PPE with contaminated gloves
- Do not touch environmental surfaces except as necessary during patient care.

Double gloving is recommended during some Exposure Prone Procedures (EPPs) e.g. orthopaedic and gynaecological operations or when attending major trauma incidents.

For appropriate glove use and selection:

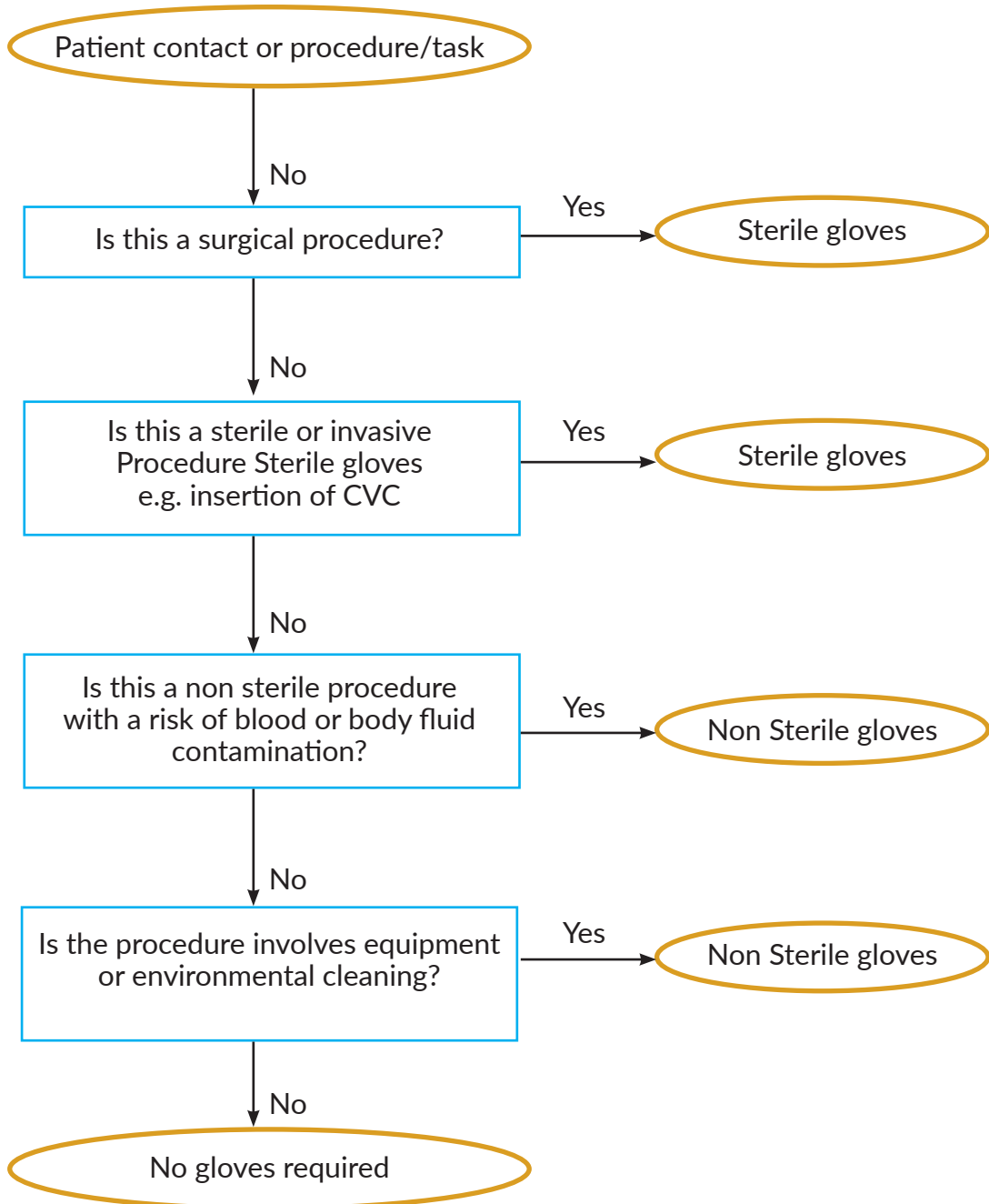

Isolation Gowns and Aprons

1. Clinical and laboratory coats or jackets worn over personal clothing for comfort and/or purposes of identity are not considered PPE.
2. Disposable plastic aprons should be worn when there is a risk that clothing or uniform may become exposed to blood, body fluids, secretions and excretions, with the exception of sweat.
3. Full body gowns need only be used where there is the possibility of extensive splashing of blood, body fluids, secretions or excretions and should be fluid repellent.
4. However, when contact precautions are used to prevent transmission of an MDRO, donning of both gown and gloves prior to room entry, regardless of the anticipated level of contact, may reduce unanticipated contact with an MDRO in the environment.
5. The practice of routine gowning upon entrance into an intensive care or other high risk area does not prevent colonisation or infection of patients.
6. Removal of isolation gowns before leaving the patient care area is advised to prevent opportunities for possible contamination outside the patient's room.

Face Protection: Masks, Goggles, Face Shields

1. Masks are used for three primary purposes in healthcare settings:
 - a. to protect health care workers from contact with infectious material from patients e.g. respiratory secretions and sprays of blood or body fluids as defined in standard and droplet precautions.
 - b. worn by healthcare workers when engaged in procedures requiring sterile technique to protect patients from exposure to infectious agents carried in a healthcare worker's mouth or nose.
 - c. placed on coughing patients to limit potential dissemination of infectious respiratory secretions from the patient to others (i.e.. Respiratory Hygiene/ Cough Etiquette).
2. Two types of mask available, the surgical mask and particulate respirator (e.g. N95) used to prevent inhalation of small particles that may contain infectious agents transmitted via the airborne route.
3. Personal eyeglasses and contact lenses are NOT considered adequate eye protection.

4. Disposable or non-disposable face shields may be used as an alternative to goggles. As compared with goggles, a face shield can provide protection to other facial areas in addition to the eyes.
5. Removal of a face shield, goggles and mask can be performed safely after gloves have been removed, and hand hygiene performed.

If the masks are used, then they should:

- Be worn according to the manufacturer's instructions.
- The front of the mask should not be touched by hands while being worn and must be removed by untying and handling only by the ties and never by the face-covering part which may be heavily contaminated with microorganisms.
- Not be worn loosely around the neck, but be removed and discarded as clinical waste as soon as practicable after use.



Respiratory protection

Air-purifying respirators (APRs) work by removing gases, vapours, aerosols (droplets and solid particles), or a combination of contaminants from the air through the use of filters, cartridges, or canisters.

1. Personal respiratory protection is required when dealing with micro-organisms that spread by droplet and airborne route. It should be worn during the performance of aerosol-generating procedures (e.g. intubation, bronchoscopy, suctioning) of patients with SARS, MERS-CoV infection, avian influenza, pandemic influenza and other novel respiratory syndromes. In these instances, surgical masks are not effective protection.
2. The respirator provides protection against inhalation of very tiny (<5 microns in size) airborne particles to the HCWs
3. Respiratory protection currently requires the use of a respirator with N95 or higher filtration – see Table A
4. (N series respirators provide protection against non-oil-based aerosols including *Mycobacterium tuberculosis* and the '95' indicates that the mask material is capable of 95 % efficient filtration of particles 0.3 μ m in diameter.
5. The appropriate respirator for a particular situation will depend on the environmental contaminant(s).



Table A: Type of respirator

Filtering Facepiece Respirator (FFR)	
<ul style="list-style-type: none"> • Disposable • Covers the nose and mouth • Filters out particles such as dust, mist, and fumes • Select from N, R, P series and 95, 99, 100 efficiency level • Does NOT provide protection against gases and vapours • Fit testing required 	
Powered Air Purifying Respirator (PAPR)	
<ul style="list-style-type: none"> • Can be used to protect against gases, vapours, or particles, if equipped with the appropriate cartridge, canister, or filter • Battery-powered with blower that pulls air through attached filters or cartridges • Provides eye protection • Low breathing resistance • Loose-fitting PAPR does NOT require fit testing and can be used with facial hair • Tight-fitting PAPR requires fit testing 	

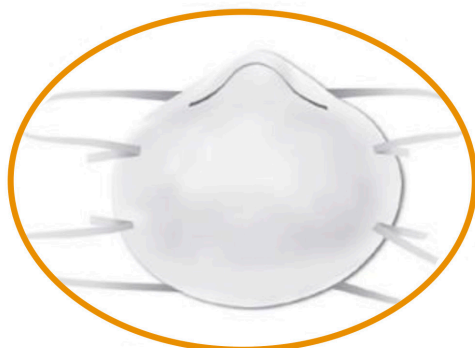

N95 Filtering Facepiece Respirator

or



Surgical Mask

	Close Contact	Aerosol-Generating Procedure
SEASONAL INFLUENZA		
Patient with suspected or confirmed seasonal influenza	Surgical mask	N95 Filtering Facepiece Respirator (FFR) equivalent or higher
AIRBORNE PRECAUTIONS		
Patient with suspected or confirmed infectious disease requiring airborne precautions (e.g. measles, tuberculosis)	N95 Filtering Facepiece Respirator (FFR) equivalent or higher	N95 Filtering Facepiece Respirator (FFR) equivalent or higher
DROPLET PRECAUTIONS		
Patient with suspected or confirmed infectious disease requiring droplet precautions (e.g. Pertussis, Mumps)	Surgical mask equivalent or higher	N95 Filtering Facepiece Respirator (FFR) equivalent or higher

A. Fit Test

1. Fit test is important to assure the expected level of protection is provided by minimizing the total amount of contaminant leakage into the respirator.
2. It is done to verify that a respirator is both comfortable and that the size correctly fits the user. It can be done via 2 ways
 - A. **Qualitative testing kit** where it relies on the respirator wearer's sense of taste and involuntary cough (irritant smoke) to determine if there is a gap in the seal of the respirator use.
 - a. Usually uses OSHA -accepted qualitative fit testing kit either using one of the below :
 - i. a sweet tasting aerosol mist
 - ii. a bitter tasting aerosol mist

- b. Qualitative Fit test kit is strongly recommended to be available for user assessment at all healthcare facilities.

B. Respiratory User Seal – check (Fit- check)

- a. It is a procedure conducted by the respirator wearer to determine if the respirator is properly sealed to the face.
- b. Respirator user Seal Check is performed every time the respirator is to be worn by the user.
- c. The user check is performed as a positive and negative pressure check.
- d. A positive pressure check is when the person wearing the respirator exhales gently while blocking the paths for the air to escape around the face piece. A successful test creates a slight pressure and causes the facepiece to fill up but there is no leak of air to the surrounding.
- e. A negative pressure check is when the person wearing the respirator inhales sharply while blocking the paths for the air to enter around the face piece and the respirator collapses slightly under negative pressure.

When should it be done

- Qualitative fit testing should be done everytime when there is a change in the brand, model and size of respirator facepiece and if weight of user fluctuates or facial/dental alterations occur. Otherwise, fit testing recommended to be performed at least annually to ensure continued adequate fit.
- Respirator user Seal Check is performed every time the respirator is to be worn by the user.

3.3 Disinfectant & Sterilisation

Patient Care Equipment (*Please refer to Chapter 13: Disinfectants & Sterilisation*)

All single-use medical equipment should preferably not be re-used. Healthcare facilities should ensure that all reusable medical equipment (e.g. blood glucose meters and other point-of-care devices, surgical instruments, endoscopes) is cleaned and reprocessed appropriately prior to use on another patient. Reusable medical equipment must be cleaned and reprocessed (disinfection or sterilisation) and maintained according to the manufacturer's instructions and MOH protocol. HCWs must wear appropriate PPE when handling and reprocessing contaminated patient equipment.

3.4 Environmental Hygiene

Facilities should establish policies and procedures for routine cleaning and disinfection of environmental surfaces as part of their infection prevention plan. The implementation of the cleaning and disinfection processes is either by the HCWs or the appointed maintenance company. All documentations pertaining the policy, procedure, classification, and practice shall comply with the current regulations of the Department of Environment.

Cleaning refers to the removal of visible soil and organic contamination from a device or environmental surface using the physical action of scrubbing with a surfactant or detergent and water or appropriate chemical agents. Emphasis for cleaning and disinfection should be placed on surfaces that are most likely to become contaminated with pathogens, including those in close proximity to the patient (e.g. bedrails) and frequently touched surfaces in the patient-care environment (e.g. doorknobs). Facility policies and procedures should also address prompt and appropriate cleaning and decontamination of spills of blood or other potentially infectious materials.





Environmental services staff should be trained and responsible for routine cleaning and disinfection of environmental surfaces. Cleaning procedures can be periodically monitored or assessed to ensure that they are consistently and correctly performed. HCWs should follow the manufacturer's recommendations for use of products selected for cleaning and disinfection (e.g. amount, dilution, contact time, safe use and disposal).

The area coverage of the cleansing services shall include the following user areas: Medical, specialized, general and other areas as described in the maintenance contract or agreement.

- The area coverage of cleansing services **EXCLUDES**:
 - Kitchen – Food rack, internal surface of kitchen hood, cooking utensils, cold room and equipment
 - Mortuary - Body freezer (internal) and cold room
 - Grease trap (grease trap compartment)
 - BEMS equipment
 - Removal of any animal carcasses
 - Ambulance

Colour coding of mop heads and cleaning cloth used in the cleansing services: The cleaning services should use the following colour code accordingly:



Colour	Type	Description	
RED	Mop Head	<ul style="list-style-type: none"> • Toilets • Dirty Utility • Sluice Room 	
			
			
			
	Dust Mop Head		

Colour	Type		Description
BLUE	Mop Head		Medical Areas / Clinics <ul style="list-style-type: none"> • Clinics (Examination Room, Waiting Area and Treatment Room) • All wards • Pantry (within wards)
	Wiping Cloth		
	Dust Mop Head		

Colour	Type	Description
GREEN	Mop Head	<p>Specialized Area and Spillages</p> <ul style="list-style-type: none"> • Operation room/ Theatre • Laboratories • Pharmacy • Central Sterile Services Unit(CSSD)/ Department • Blood Bank • Burns Unit • Labour Room • All Intensive Care Units • Iodine Room • Imaging and Diagnostic Rooms • Chemo Room • Scope Room • Isolation Wards / Rooms • Accident and Emergency Unit • Milk Room • Dental Department/ Clinics • Procedure Room • Haemodialysis Unit (HDU)
	Wiping Cloth	
	Dust Mop Head	

Colour	Type		Description
YELLOW	Mop Head	 	General Areas (Non-Clinical Areas) <ul style="list-style-type: none"> • Corridors • Lift lobbies at multi-storey carparks • Lobbies • Staircases • Lifts • Offices / Administration • Stores • Kitchen / Dining areas • Balcony • Pavement (foot path to attached building) • Pantry • Washing/Drying Area (patient) within ward • Canteen / Cafeteria (except food preparation, tables, chairs, counters, food serving area)
	Wiping Cloth		Other areas <ul style="list-style-type: none"> • Polyclinics (within the Contract Hospital compound) • Seminar Rooms • Auditoriums • Rehabilitation • Mortuary • Hostels/Quarters (within the Contract Hospital) • Sport Clubs

YELLOW	Dust Mop Head		<ul style="list-style-type: none"> • Garages (except pre-mix floor) • Security Post and Security Office/Guard House • Bus Stop within Hospital Compound • Mosque/Surau • Drain (Perimeter) • Grease Traps (External Only) • Flat Roof excluding Engineering Facilities • Lobbies • Corridors • Elevators/ Escalators/ Travelator
---------------	---------------	---	--

Colour	Type	Description
WHITE	Mop Head	<ul style="list-style-type: none"> • Polishing Floor • Metal polishing
	Wiping Cloth	
	Dust Mop Head	

**The colour of the mop, wiping cloth and dust mop head are subjected to changes due to contract review, availability of material and technology and practices in the near future.*

3.5 Waste Management

Waste generated by health care activities includes a broad range of materials, from used needles and syringes to soiled dressings, body parts, diagnostic samples, blood, chemicals, pharmaceuticals, medical devices and radioactive materials.

Of the total amount of waste generated by health-care activities, about 85% is general, non-hazardous waste comparable to domestic waste. The remaining 15% is considered hazardous material that may be infectious, chemical or radioactive.

Poor management of health care waste potentially exposes health care workers, waste handlers, patients and the community at large to infection, toxic effects and injuries, and risks polluting the environment. It is essential that all medical waste materials are segregated at the point of generation, appropriately treated and disposed of safely.

Wastes from hospitals and healthcare establishments can be categorized into the following types:





- i. Clinical waste;
- ii. Radioactive waste;
- iii. Hazardous chemical waste;
- iv. Pharmaceutical waste;
- v. Electric/electronic equipment waste;
- vi. Pressurized containers; and
- vii. General waste.



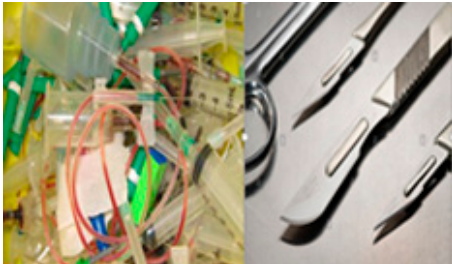

Clinical waste shall be defined as:

- Any waste which consists of wholly or partly of human or animal tissues, blood or other body fluids, excretions, used drug, swabs dressings, syringes, needles or other instruments, being waste which unless rendered safe may prove hazardous to any other person coming into contact with it; and
- Any other waste arising from medical, laboratory, nursing, dental, veterinary, investigation, treatment, care, teaching or research, or the collection of blood for transfusion, being waste which cause infection to any other person coming into contact with it.



Types of waste and segregation

Types	Example	Waste Segregation
<p>Clinical Waste Group A</p>	<ul style="list-style-type: none"> waste contaminated with blood and other bodily fluids (e.g. soiled gloves, plasters, swab, cotton wool, dressing ,bandages etc), pathological waste including all human tissue, organ, body parts, placenta, tissue from laboratories etc. 	
<p>Clinical Waste Group B</p>	<ul style="list-style-type: none"> Sharp waste E.g. syringes, needles, disposable scalpels and blades and other sharp instruments that could cause a cut or puncture. <p>Trocar is recommended to be discarded into a well fit trocar container.</p> 	

Types	Example	Waste Segregation
<p>Clinical Waste Group C</p>	<p>Waste from laboratory</p> <p>E.g. used culture plates, tubes, bottles, blood culture bottles</p> 	
<p>Clinical Waste Group D</p>	<p>Pharmaceutical waste</p> <p>E.g. expired, unused and contaminated drugs and vaccines</p> 	

Types	Example	Waste Segregation
<p>Clinical Waste Group E</p>	<p>Disposable medical instruments (non sharp)</p> <p>E.g. Bed pan, stoma bag , incontinence pad, urine container</p> 	
<p>General waste (non clinical / non hazardous waste)</p>	<p>Waste that does not pose any particular infectious/ biological, chemical, radioactive or physical hazard</p>	

**The colour of the plastic bag are subjected to changes due to availability of material and technology and practices in the near future.*

Flow chart for types of waste and its segregation

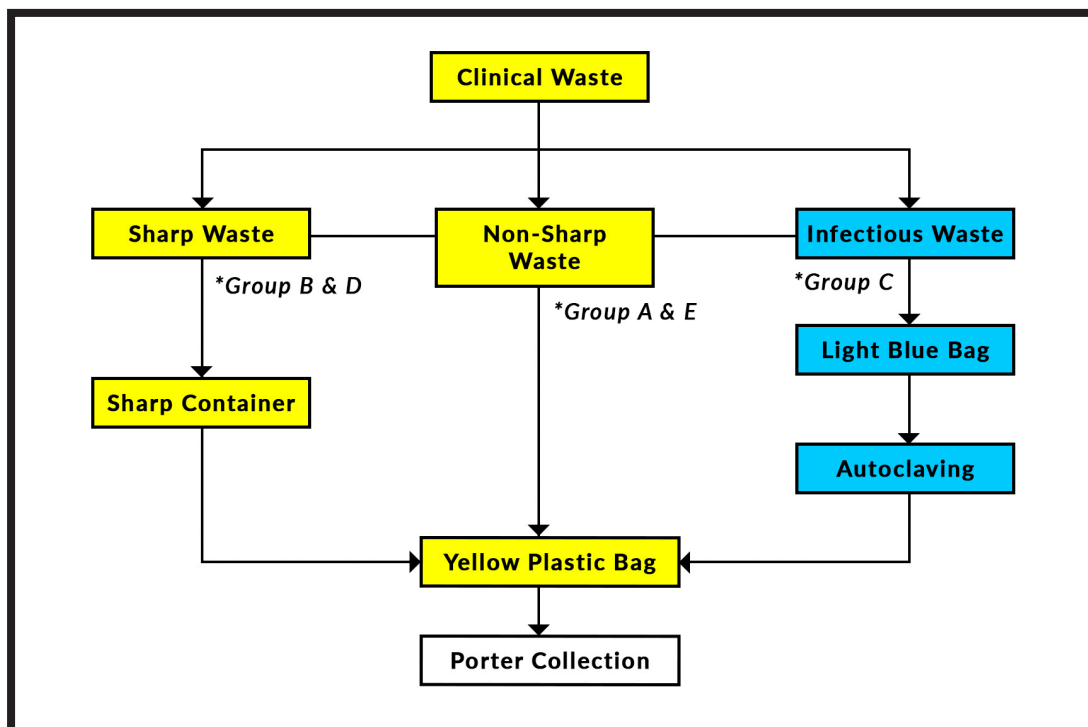

HCWs Responsibilities

- Clinical waste (Group A and E) shall be discarded into yellow colour coded bags for collection.
- Infectious type of clinical waste (Group C) shall be placed into blue plastic bag for autoclave before putting into the yellow bag for collection.
- Used sharps shall be discarded into a sharp container.
- Do not removed needle from the syringes.
- All syringes without needles discarded into clinical waste bin.
- DO NOT disconnect used Intravenous giving set. It should be tightly secured and put into the clinical waste bin.
- Sharps containers when filled to the fill line ($\frac{3}{4}$ full) shall be sealed to prevent further filling of sharps. A new container shall be taken and covers locked into place before putting into use.

3.6 Linen Management

Introduction:

Linen in a health-care facility may include bed sheets and blankets, towels, personal clothing, patient apparel, uniforms, scrub suits, gowns, and drapes for surgical procedures. It is widely accepted that high-quality laundries produce safe, reusable textiles through rigorous implementation of commercial laundering formulas, which carefully calibrate time, temperature, chemistry and mechanical action. When linen is heavily contaminated with potentially infective body substances, they can contain bacterial loads of higher than 10^6 – 10^8 CFU/100 cm² of fabric. Contaminated linen may be a source for HCAI and an outbreak.

a) Hygienic clean linen supply

Thus, all hospitals and other medical facilities should receive hygienic clean linen supply for their use. This is determined by adhering to good policies and practices of hygienic and clean storage and handling of the linen at every level. This ensures safety of clients/patients who are hospitalised or receive day-care procedures.

The employees handling the hygienic clean linen must be well trained. The employees or HCW should follow proper hand hygiene procedures and sanitize prior to handling clean healthcare linens and after touching potentially contaminated surfaces. They should don appropriate PPE (apron and mask) but gloving is not required.

i) Storage

Adequate storage space is very important to keep the clean linen prior to distribution. It must be kept separate from any soiled linen area and other possible contaminants.

Requirements for the storage area:

- Clean, not dusty, free of vermin and away from drains and pipes.
- Temp to 20-25 degree Celsius (in the air-conditioned area)
- Linen cupboard must always be kept closed to reduce dust accumulation.
- Cupboard and shelves must not be made of wooden material. The materials must be solid and easily cleaned.
- Shelves in the storage should be 5 cm from the walls, 20-25 cm from the floor, 50 cm from the ceiling. "First in, first out" (FIFO) must be adhered to based on date of supply (date must be stated on the packet)

- Regular cleaning schedules (daily) of the cupboard and shelves must be done and documented regularly.
- Clean linen must never be placed on the floor or contaminated surfaces
- Linen storage facilities are to be used for the storage of clean linen items only and not used for storage of any other equipment
- The linen that does not meet the clean hygienic standards should be rejected and returned.

ii) Transportation and Distribution

- The hygienically clean linen should be wrapped before transportation from the laundry plant but need to avoid plastic wrapper in view of local humidity and temperature.
- Carts transporting hygienic clean linen from laundry to medical facilities must be clean.
- The clean linen must be covered during the transport to the central storage and delivery to the wards/units.
- Carts used for clean or soiled linen must be separated with physical barriers.
- If clean linen is taken into an isolation area and not used the linen must be laundered again before storage/use.
- Staff member should avoid pressing/hugging hygienic clean linen to their uniforms at any times. This is important to prevent cross contamination via the staff's uniform:
 - Unloading from laundry bins or trucks onto racks in a clean linen storage area
 - Moving clean linen from storage area to carts
 - Removing clean linen from linen carts to a patient room
 - When clean linen are being used to make a patient bed

3.6.1 Soiled / dirty linen

Used linen soiled with blood, body fluids, secretions and excretions should be handled, transported and processed in a manner that prevents skin and mucus membrane exposure. Contamination of clothing and transfer of micro-organisms to other patients and the environment should be avoided. Adherence to standard precautions when handling contaminated linen and minimizing agitation of the contaminated items are considered sufficient to prevent the dispersal of potentially infectious aerosols.



Types

<p>White Linen Bag</p>  <p>For all normal soiled and foul linen</p>	<p>Green Linen Bag</p>  <p>For all Operation Theatre / CSSD linen</p>	<p>Red Linen Bag</p>  <p>For Infected linen to be lined with Red Alginate Plastics</p>
<p>Brown Linen Bag</p>  <p>For Reject Linen</p>	<p>Red Alginate Plastics</p>  <p>Red in colour, the material shall be fully dissolvable during washing process.</p>	

HCWs Responsibilities

In performing this, HCWs must don appropriate PPE (apron, mask and gloves) and perform hand hygiene beforehand.

- To segregate and remove any foreign items before placing soiled linen in the appropriate colour coded bags.

- To tie the soiled linen bag when it is $\frac{3}{4}$ full and replace with another bag. Red Linen Bag to be lined with Alginate Bag.
- To place soiled linen bags neatly on the racks at the Used Soiled Linen Area.
- To place contaminated linen directly into a laundry bag in the isolation room/area with minimal manipulation to avoid contamination of air, surfaces and persons

Used linen awaiting collection must be stored in a secure area away from public access and in the appropriately labelled wheelie bin. Do not transport linen in trash carts and trash on linen carts. Never move soiled and clean linen on the same carts.

3.6.2 Waterproof pillows and bedcover

Waterproof pillows and bed cover must not be sent to the laundry for laundering.

All pillows and bed must be covered by an impervious waterproof cover with welded not stitched seams. If they becomes soiled or damaged, it must be discarded and recorded as condemned.

All pillows and bedcover must be marked with the ward or area name in permanent marker pen.

3.7 Spillage Management

Management of spillage in healthcare facilities is very important. The process of spills management differ based on the setting in which they occur and the volume of the spills. The management of spillage within hospital as per maintenance contract shall be strictly followed.

- In patient-care areas, healthcare workers can manage small spills by cleaning with detergent solution.
- for spills containing large amounts of blood or other body substances, workers should contain and confine the spill by:
 - removing visible organic matter with absorbent material (e.g. disposable paper towels)
 - removing any broken glass or sharp material with forceps
 - soaking up excess liquid using an absorbent clumping agent (e.g. absorbent granules)



The table below demonstrates appropriate processes when managing spills.

If spillage has occurred on soft furnishings, a detergent solution can be used to clean the area thoroughly. Do not clean soft furnishings with a disinfectant such as sodium hypochlorite. Soft furnishings can also be wet vacuumed. Following cleaning of soft furnishings, every effort must be made to air the room to allow drying of the furnishing before reuse.

Alcohol solutions should not be used to clean spillages (HPS 2006).

Any spillage must be cleaned as soon as possible.
(Please refer to definition of small or large spills)

Spot cleaning	<ul style="list-style-type: none">- Select appropriate PPE- Wipe up spot immediately with a damp cloth, tissue or paper towel- Discard contaminated materials- Perform hand hygiene
Small spills (up to 10cm diameter)	<ul style="list-style-type: none">- Select appropriate PPE- Wipe up spill immediately with absorbent material- Place contaminated absorbent material into impervious container or plastic bag for disposal- Clean the area with warm detergent solution, using disposable cloth or sponge- Wipe the area with sodium hypochlorite and allow to dry- Perform hand hygiene
Large spills (greater than 10cm diameter)	<ul style="list-style-type: none">- Select appropriate PPE- Cover area of the spill with an absorbent clumping agent and allow to absorb- Use disposable scraper and pan to scoop up absorbent material and any unabsorbed blood or body substances- Place all contaminated items into impervious container or plastic bag for disposal- Discard contaminated materials- Mop the area with detergent solution- Wipe the area with sodium hypochlorite and allow to dry- Perform hand hygiene

Small spills

Remove with absorbent material, wipe with Sodium hypochlorite 1:10 or other suitable disinfectant solutions.

Large spills

- Cover spillage with absorbent material, pour Sodium hypochlorite 1:10 and leave for 5-10 min.
- Wipe up with absorbent material and place in yellow bin.
- Sprinkle chloride granules leave for 5-10 min.
- Scoop with brush and dust pan and discard into clinical waste bin.
- Mop the area with Sodium hypochlorite 1:100.

3.8 Injection safety & Sharps management

What is a safe injection (1)

A safe injection, phlebotomy (drawing blood), lancing procedure or intravenous device insertion is one of that:

- Does not harm the recipient;
- Does not expose the provider to any avoidable risk;
- Does not result in any waste that is dangerous for other people.

Unsafe injection practices put patients at risk for bacterial, fungal, viral, and parasitic infections:

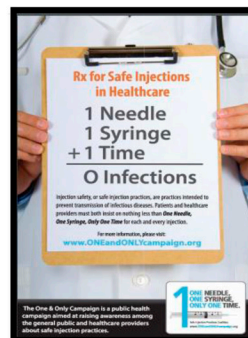

The following practices are recommended to ensure the safety of injections and related practices:

- Hand Hygiene;
- Gloves where appropriate;
- Other single-use personal protective equipment;
- Skin preparation and disinfection.

Skin preparation and disinfection

The following antiseptics are recommended for use prior to intradermal, subcutaneous, intramuscular and venous access procedures;

- Unsoiled skin, use 70% alcohol swab

Practical guidance on skin preparation and disinfection

To disinfect skin, use the following steps:

1. Apply a 70% alcohol-based solution on a single-use swab or cotton-wool ball. If skin is visibly soiled, skin should be cleaned with soap and water
2. Wipe the area from the centre of the injection site working outwards, without going over the same area.
3. Apply the solution for 30 seconds and allow to dry for a further 30 seconds to ensure bacteria are rendered inactive.

DO NOT pre-soak cotton wool in a container - these become highly contaminated with hand and environmental bacteria

DO NOT use alcohol skin disinfection for administration of vaccinations.

DO	DO NOT
Do carry out hand hygiene (use soap and water or alcohol rub), and wash carefully, including wrists and spaces between the fingers, for at least 30 seconds (follow WHO's 'My 5 moments for hand hygiene'*)	DO NOT forget to clean your hands

DO use one pair of non-sterile gloves per procedure or patient	DO NOT use the same pair of gloves for more than one patient DO NOT wash gloves for reuse
DO use a single-use device for blood sampling and drawing	DO NOT use a syringe, needle or lancet for more than one patient.
Do disinfect the skin at the venepuncture site	DO NOT touch the puncture site after disinfecting it.
Do discard the used device (a needle and syringe in a single unit) immediately in a robust sharps container..	Do NOT leave the unprotected needle lying outside the sharp container.
When recapping a needle is unavoidable, Do use one-hand scoop technique (see Annex B)	DO NOT recap a needle using both hands
DO seal the sharp container with a temper-proof lid	DO NOT overfill or decant a sharp container
DO place laboratory sample tubes in a sturdy rack before injecting into the rubber stopper	DO NOT inject into the laboratory tube while holding it with the other hand.
DO immediately report any incident or accident linked to a needle or sharp injury, start PEP as soon as possible, following protocols	DO NOT delay PEP after exposure to potentially contaminated material; beyond 72 hours, PEP is not effective
PEP: post exposure prophylaxis, WHO: World Health Organisation * World Health Organisation (30)	



Injection devices and medications

Injection Devices

Health-care facilities should ensure that an adequate supply of single-use devices are available, to allow providers to use a new device for each procedure.

Practical guidance on use of injection devices

When using a sterile single-use device:

- use a new device for each procedure, including for the reconstitution of a unit of medication or vaccine;
- inspect the packaging of the device to ensure that the protective barrier has not been breached;
- discard the device if the package has been punctured, torn or damaged by exposure to moisture, or if the expiry date has passed.

Medication

Practical guidance on giving medications

When giving medication:

- DO NOT use a single loaded syringe to administer medication to several patients (i.e.. ensure one needle, one syringe, one patient!);
- DO NOT change the needle in order to reuse the syringe;
- DO NOT use the same mixing syringe to reconstitute several vials;
- DO NOT combine leftover medications for later use.

Single-dose vials – Whenever possible, use a single-dose vial for each patient, to reduce cross-contamination between patients.

- *Multidose vials* – Only use multidose vials if there is no alternative.
- Open only one vial of a particular medication at a time in each patient-care area.
- If possible, keep one multidose vial for each patient, and store it with the patient's name on the vial in a separate treatment or medication room.
- DO NOT store multidose vials in the open ward, where they could be inadvertently contaminated with spray or spatte.

Discard a multidose vial:

- if sterility or content is compromised;
- if the expiry date or time has passed (even if the vial contains antimicrobial preservatives);
- if it has not been properly stored after opening

Preparing Injections

Injections should be prepared in a designated clean area where contamination by blood and body fluids is unlikely.

Practical guidance on preparing injections

Three steps must be followed when preparing injections.

1. Keep the injection preparation area free of clutter so all surfaces can be easily cleaned.
2. Before starting the injection session, and whenever there is contamination with blood or body fluids, clean the preparation surfaces with 70% Alcohol and allow to air dry.
3. Assemble all equipment needed for the injection

Procedure for septum vials

Wipe the access diaphragm (septum) with 70% alcohol on a swab or cotton-wool ball before piercing the vial, and allow to air dry before inserting a device into the bottle.

- Use a sterile syringe and needle for each insertion into a multidose vial.
- Never leave a needle in a multidose vial.
- Once the loaded syringe and needle has been withdrawn from a multidose vial, administer the injection as soon as possible.

Labelling

After reconstitution of a multidose vial, label the final medication container with date and time of preparation;

Administering Injections

Aseptic technique should be followed for all injection



Practical guidance on administering injections

General

When administering an injection:

- check the drug chart or prescription for the medication and the corresponding patient's name and dosage;
- perform hand hygiene;
- wipe the top of the vial with 70% alcohol (isopropyl alcohol or ethanol) using a swab or cotton-wool ball;
- open the package in front of the patient to reassure them that the syringe and needle have not been used previously;
- using a sterile syringe and needle, withdraw the medication from the ampoule or vial.

Reconstitution

- If reconstitution using a sterile syringe and needle is necessary, withdraw the reconstitution solution from the ampoule or vial, insert the needle into the rubber septum in the single or multidose vial and inject the necessary amount of reconstitution fluid.
- Mix the contents of the vial thoroughly until all visible particles have dissolved.
- After reconstituting the contents of a multidose vial, remove the needle and syringe and discard them immediately as a single unit into a sharps container.

Needleless system

If a needleless system is available:

- wipe the rubber septum of the multidose vial with an alcohol swab;
- insert the spike into the multidose vial;
- wipe the port of the needleless system with an alcohol swab;
- remove a sterile syringe from its packaging;
- insert the nozzle of the syringe into the port;
- withdraw the reconstituted drug.

Delay in administration

If the dose cannot be administered immediately for any reason, cover the needle with the cap using a one-hand scoop technique.

Prevention of sharps injuries to healthcare workers

Use of best practices can help to prevent sharps injuries to health workers. Further information on this topic can be found in Chapter 11.

Sharps Management

Safe waste and sharps disposal

Recommendation on safe disposal of sharps

The blood-sampling device - a needle and syringe, evacuated needle and tube holder, or winged butterfly-should be disposed of immediately after use as a single unit. It should be placed in a puncture-proof, leak-proof, closable sharp container that is clearly visible and is paced within arm's reach of a health worker.

Phlebotomy Procedure

Best practices in phlebotomy

Best practices in phlebotomy involve the following factors:

- planning ahead;
- using an appropriate location;
- quality control / assurance (Table lists the main components of quality assurance)

Element	Notes
Education and training	Education and training is necessary for all staff carrying out phlebotomy. It should include an understanding of anatomy, awareness of the risks from blood exposure, and the consequences of poor infection prevention and control.
Standard operating procedures (SOP)	SOPs are required for each step or procedure. They should be written and be ready available to health workers.

Correct identification of the patient	<p>Identification should be through matching to the laboratory request form.</p> <p>For blood donation, the identity of the donor should be accurately matched to the results of screening tests.</p> <p>For blood sampling, after samples have been taken from a patient or donor; a system of identification and tracking is essential to ensure that the sample is correctly matched with the result and with the patient or donor.</p>
The condition of the sample	The condition of the sample should be such that the quality of the results is satisfactory.
Safe transportation	Making safe transportation of blood or blood products part of best practices will improve the quality of results from laboratory testing
An incident reporting system	A system is required for reporting all adverse events. A log book or register should be established with accurate details of the incident, possible causes and management of adverse events

- standards for quality care for patients and health care workers, including
 - availability of appropriate supplies and protective equipment
 - availability of post-exposure prophylaxis (PEP)
 - avoidance of contaminated phlebotomy equipment
 - appropriate training in phlebotomy
 - cooperation on the part of patients

- quality of laboratory sampling

Procedure for drawing blood

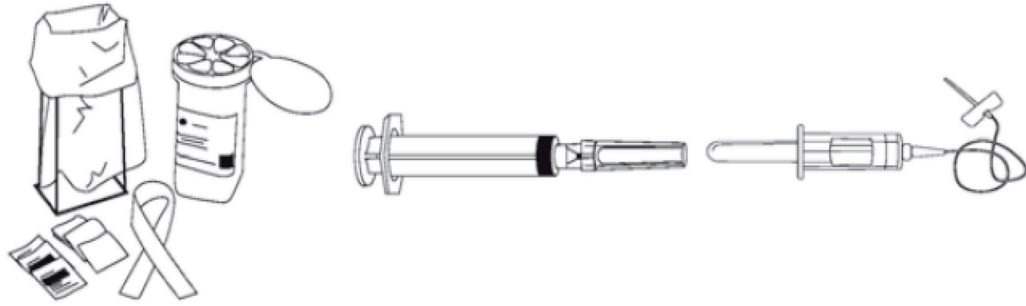

1. Assemble equipment, and include needle and syringe or vacuum tube, depending on which is to be used.

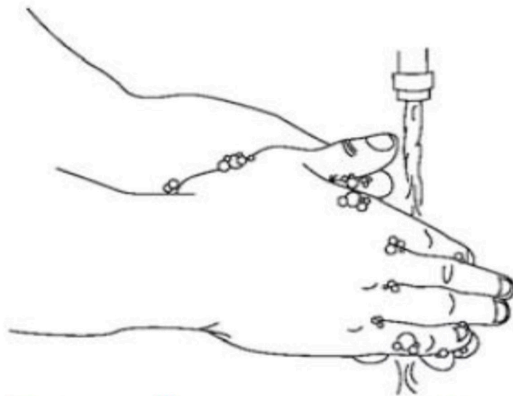

2. Perform hand hygiene (if using soap and water, dry hands with single-use towels).



3. Identify and prepare the patient.

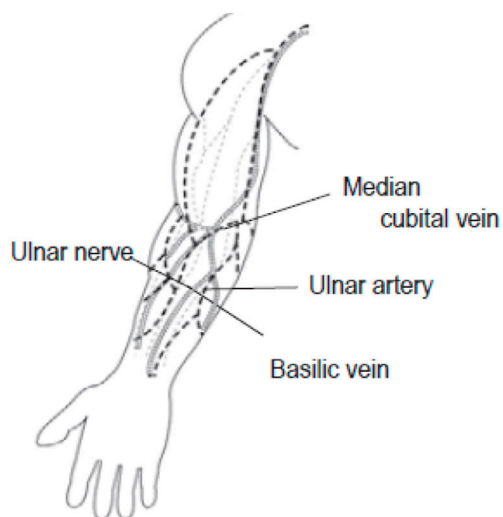

4. Select the site, preferably at the antecubital area (i.e. the bend of the elbow). Warming the arm with a hot pack, or hanging the hand down may make it easier to see the veins. Palpate the area to locate the anatomic landmarks. **DO NOT** touch the site once alcohol or other antiseptic has been applied.
5. Apply a tourniquet, about 4–5 finger widths above the selected venipuncture site.

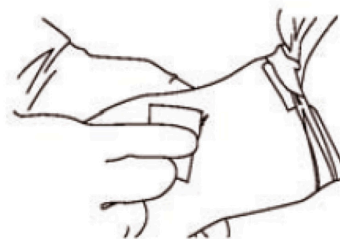

6. Ask the patient to form a fist so that the veins are more prominent.
7. Put on well-fitting, non-sterile gloves.
8. Disinfect the site using 70% isopropyl alcohol for 30 seconds and allow to dry completely (30 seconds).



9. Anchor the vein by holding the patient's arm and placing a thumb **BELOW** the venepuncture site.

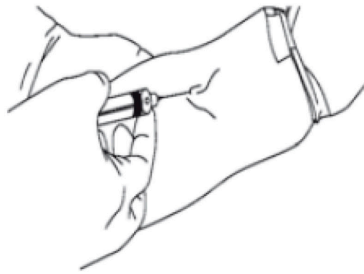

10. Enter the vein swiftly at a 30 degree angle.

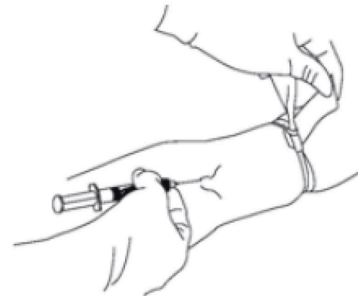

11. Once sufficient blood has been collected, release the tourniquet **BEFORE** withdrawing the needle



12. Withdraw the needle gently and then give the patient a clean gauze or dry cotton-wool ball to apply to the site with gentle pressure.



13. Discard the used needle and syringe or blood-sampling device into a puncture-resistant container.

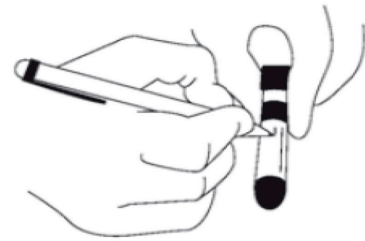

14. Check the label and forms for accuracy.

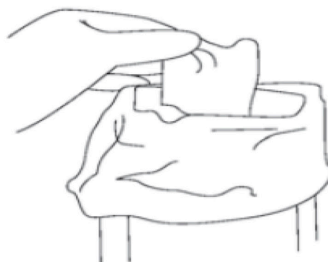

15. Discard sharps and broken glass into the sharps container. Place items that can drip blood or body fluids into the infectious waste.

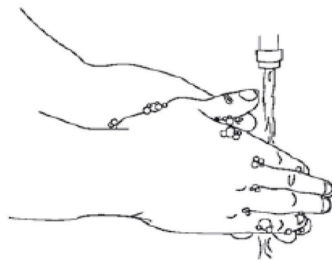

16. Remove gloves and place them in the general waste. Perform hand hygiene. If using soap and water, dry hands with single-use towels.

3.9 Respiratory Hygiene & Cough Etiquette

Respiratory hygiene/cough etiquette

Controlling the spread of pathogens from infected patients (source control) is key to avoid transmission to unprotected contacts. For diseases transmitted through large droplets and/or droplet nuclei, respiratory hygiene/cough etiquette should be applied by all individuals with respiratory symptoms.

All individuals (HCWs, patients and visitors) with signs and symptoms of a respiratory infection should:

- Cover their mouth and nose when coughing/sneezing;
- Use tissues, handkerchiefs, cloth masks or medical masks if available, as source control to contain respiratory secretions, and dispose of them into the waste containers;
- Use a medical mask on a coughing/sneezing person when tolerated and appropriate; and perform hand hygiene.

Hospital should promote respiratory hygiene / cough etiquette:

- Promote the use of respiratory hygiene/cough etiquette by all HCWs, patients and family members with acute febrile respiratory illness;
- Educate HCWs, patients, family members, and visitors on the importance of containing respiratory aerosols and secretions to help prevent the transmission of respiratory diseases;
- Consider providing resources for hand hygiene (e.g. dispensers of alcohol-based hand rubs, hand-washing supplies) and respiratory hygiene (e.g. tissues) in areas of gathering, such as waiting rooms, should be prioritized.

Sequence of a particular respirator seal check



1. Cup the respirator in your hand with the nosepiece at your fingertips allowing the headbands to hang freely below your hand



2. Position your respirator under your chin with the nose-piece up



3. Pull the top strap over your head resting it high at the back of your head. Pull the bottom strap over your head and position it around the neck below the ears



4. Place fingertips of both hands at the top of the metal nose-piece. Mould the nose-piece (USING TWO FINGERS OF EACH HAND) to the shape of your nose. Pinching the nose-piece using the hand may result in less effective respirator performance



5. Cover the front of the respirator with both hands, being careful not to disturb the position of respirator



5A Positive seal check

- Exhale sharply. A positive pressure inside the respirator = no leakage. If leakage, adjust position and/or tension straps. Retest the seal.
- Repeat the steps until respirator is sealed properly

5B Negative seal check

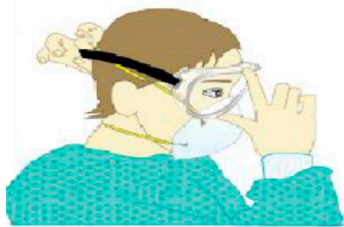

- Inhale deeply. If no leakage, negative pressure will make respirator cling to your face.
- Leakage will result in loss of negative pressure in the respirator due to air entering through gaps in the seal.

Donning on PPE (when all PPE items are needed)



	<ul style="list-style-type: none">• Identify hazards & manage risk.• Gather the necessary PPE.• PPE don before contact with patient, generally before entering the room• Do you have a buddy to assist?mirror?• Ensure items needed for waste management are available
	<ul style="list-style-type: none">• Put on a gown• Select appropriate type and size• Opening is in the back• Secure at neck and waist• If gown is too small, use two gowns<ul style="list-style-type: none">- -Gown #1 ties in front- -Gown #2 ties in back
	<ul style="list-style-type: none">• Put on particulate respirator or medical mask• Place over nose, mouth and chin• Fit flexible nose piece over nose bridge• Secure on head with ties or elastic• Adjust to fit
	<ul style="list-style-type: none">• Put on eye protection e.g face shield/ goggles• Optional: face shield, caps (to put on after eye protection)• Adjust to fit comfortably

	<ul style="list-style-type: none"> • Put on gloves • Extend gloves over isolation gown cuffs
---	--

Removing of PPE

	<ul style="list-style-type: none"> • At doorway, before leaving patient room or in anteroom <ul style="list-style-type: none"> - avoid contamination of self, others & the environment - remove the most heavily contaminated item first • Removes gloves and gown: <ul style="list-style-type: none"> - peel off gown & gloves and roll inside, out - dispose gloves and gown safely
	<ul style="list-style-type: none"> • Perform hand hygiene • Ensure that hand hygiene facilities are available at the point needed, e.g., sink or alcohol-based hand rub
	<ul style="list-style-type: none"> • Remove cap (if worn) • Remove goggles from behind • Put goggles in a separate container for reprocessing



	<ul style="list-style-type: none"> • Remove respirator from behind <ul style="list-style-type: none"> - Lift the bottom elastic over your head first - Then lift off the top elastic - Discard
	<ul style="list-style-type: none"> • Perform hand hygiene

B. TRANSMISSION BASED PRECAUTION

Transmission-Based Precautions are the second tier of basic infection control and are to be used in addition to Standard Precautions for patients who may be infected or colonized with certain infectious agents for which additional precautions are needed to prevent infection transmission.

Three types of transmission-based precautions have been developed;

- I. Contact Precaution
- II. Droplet Precaution
- III. Airborne Precaution

The core elements of each precaution are outlined below:

3.10 Contact

Contact transmission is the most common route of transmission of infectious agents. It may be any of the following:

- a. Direct contact, which occurs through touching e.g. a person may transmit microorganisms to others by touching them.
- b. Indirect contact, which occurs when microorganisms are transferred via contaminated objects or environment e.g. *C. difficile* / MRSA infections

Infections that require contact precautions are:

- a. Bacteria
 - MDRO - MRSA/ ESBL producers/VRE/CRE
 - *Clostridium difficile*
- b. Viruses
 - Respiratory virus – *Adenovirus, Influenza, Parainfluenza, Enterovirus*
 - Gastrointestinal – *Astro, Rotavirus, Hepatitis A*

Core Component	
Patient Placement	<p>In order of preference;</p> <ol style="list-style-type: none">1. Single room with attached bathroom with dedicated toilet facilities and sink2. Single room without attached bathroom3. Cohorted with patients with the same infections.4. In the general ward with an isolation tray/trolley beside the bed.
Personal Protective Equipment (PPE)	<p>Basic requirements:</p> <p>When patient is placed in isolation, the following must be worn before entering the room</p> <ul style="list-style-type: none">- Gown- Gloves <ul style="list-style-type: none">• Upon exiting the room: gloves need to be removed first before gowns.• 5 moments of Hand hygiene and elements of standard precaution must be practiced

	<p>For MDRO carriers who are nursed in a multi-bedded cubicle:</p> <ul style="list-style-type: none"> • Wear gloves and gown/ apron only when there is bodily contact (i.e.. HCP's clothing will have direct contact with the patient) or potentially contaminated environmental surfaces or equipment in close proximity to the patient. • Remove and discard gloves before removing gown / apron. • Clean hands after removing each PPE. • Where there is no bodily contact, hand hygiene is to be practised according to WHO 5 moments. • Remove gown before leaving the patient-care environment and perform hand hygiene immediately. <p><i>Mask and Face Shield should be worn for procedures/activities likely to generate splashes/sprays of blood, body fluids, secretions and excretions</i></p>
Environmental Control	<ul style="list-style-type: none"> • Bedside equipment and frequently touched surfaces are to be cleaned daily. • Clean the environmental surfaces with hospital-approved disinfectants <p>Note; Refer to chapter 12; Environmental Cleaning, for further information on specific organisms</p>
Patient care equipment and Linen	<ul style="list-style-type: none"> • Dedicate the use of non-critical patient-care equipment to avoid sharing between clients/patients/residents • E.g. stethoscope, sphygmomanometer, thermometer or bedside commode • If unavoidable, then adequately clean and disinfect them before use on another client/patient/resident • Do not wear the same gowns and gloves when going from patient-to-patient within the cohort. • Contaminated linen should be handled as little as possible to prevent gross microbial contamination of the air. Washing / Disinfecting linen should be handled according to hospital protocol

Patient movement	<p>Limit the movement and transport of the patient from the room to essential purposes only. If transport or movement is necessary,</p> <ul style="list-style-type: none"> • Use clean linen. • Cover all open wounds before transport. • Inform the receiving department of the need for Contact Precautions • Clients / patients / residents who are respiratory dispersers should wear a surgical mask en-route. • Minimize contacts with other patients and disinfect frequently touched surfaces <p><i>Staffs who accompany the client / patient / resident during the transportation are to discard gown and gloves and perform hand hygiene before leaving the room. They need not put on gown / apron and gloves during transportation.</i></p> <p>Standard precautions are to be practiced at all times</p>
------------------	---

*Isolation tray/trolley must contain the following items: non-sterile gloves, non-sterile gowns, surgical masks, thermometer, BP set, stethoscope, alcohol hand rub.

3.11 Droplet

1. Designed to prevent the transmission of diseases by particles >5 µm containing infectious agent. These droplets are larger, do not remain suspended in the air, and do not travel long distances.
2. They are produced when the infected patient talks, coughs, or sneezes, and during some procedures (e.g. suctioning and bronchoscopy). A susceptible host may become infected if the infectious droplets land on the mucosal surfaces of the nose, mouth, or eye.
3. Used in addition to Standard Precautions
Droplet Precautions are indicated in patients with the following infectious agents:
 - A) Bacteria
 - *N. meningitidis*
 - *B. pertussis*
 - *H. Influenza*
 - B) Viruses
 - Respiratory virus – *Adenovirus, Influenza, Parainfluenza, Enterovirus, Coronavirus*

Core Component	
Patient Placement	<p>In order of preference;</p> <ol style="list-style-type: none"> 1. Single room with en-suite bathroom 2. Single room 3. Cohort – place the patient in a room with a patient(s) who has active infection with the same microorganism but with no other infection. 4. In the general ward, but maintain a spatial separation of at least 3 feet between an infected patient and other patients and visitors. <p>* <i>Place an isolation trolley / tray at the entrance of the isolation zone.</i></p> <p>* <i>Droplet Precautions signage for the appropriate Personal Protective Equipment should be displayed before entering the room / area.</i></p> <p>* <i>Need to include the proper instructions of PPE removal.</i></p>
Personal Protective Equipment (PPE) / Hand Hygiene	<p>Basic Requirements:</p> <ul style="list-style-type: none"> • Gown • Gloves • Mask – A surgical mask is sufficient unless aerosol generating procedures are performed, an N95 mask should be worn (nebulizers / intubating / BAL) • Face Shield or eye protection are recommended for <i>procedures / activities likely to generate splashes / sprays of blood, body fluids, secretions and excretions</i> <ul style="list-style-type: none"> - Upon exiting the room: gloves need to be removed first before gowns. - 5 moments of Hand hygiene and elements of standard precaution must be practiced

Environmental control	Patient-care items, bedside equipment and frequently touched surfaces are cleaned daily. Clean the environmental surfaces with hospital-approved disinfectants.
Patient Care equipment and linen	(as Contact Precaution)
Patient Transport	<p>Do not Move patient Unnecessarily</p> <ul style="list-style-type: none"> • If can't be avoided, The patient should wear a surgical mask and follow Respiratory Hygiene Cough Etiquette in order to minimise the dispersal of droplet nuclei during transportation. • Receiving area should be fully aware of patients condition • Standard Precautions to be practiced always

3.12 Airborne

Airborne Precautions used in addition to Standard Precautions,

- Reduces the risk of airborne transmission of infectious agents (< 5 µm in size). Minute infectious droplets may be generated by an infectious person during coughing, sneezing, talking or performing of procedures (e.g. Intubation). These droplets remain suspended in air for long periods of time.

Airborne transmission is further classified into obligate or preferential airborne transmission:

- Obligate airborne transmission occurs with pathogens that are transmitted only by deposition of droplet nuclei under natural conditions (e.g. pulmonary tuberculosis).
- Airborne transmission occurs with pathogens such as:
 - A) Bacteria - *Mycobacterium tuberculosis*
 - B) Viruses - *Measles, Varicella-Zoster,*
 - C) Fungal - *Aspergillus, Histoplasma, P.marneffeii*

<p>Patient Placement:</p>	<p>In order of preference;</p> <ol style="list-style-type: none"> 1. Airborne Infection Isolation Room (AIIR) 2. Single room (nursed with door closed) and en-suite bath 3. Single room 4. Cohort (not recommended unless absolutely necessary) or consider transferring to a centre with AIIR. <ul style="list-style-type: none"> - consult Physicians /microbiologists <p>The room should meet the following ventilation standards:</p> <ul style="list-style-type: none"> • minimum 12 air changes per hour (ACH) • inward directional airflow from adjacent spaces to the room with negative pressure differentials of > - 2.5 Pascal. • supply of clean air flowing first to the area of the room where staff or visitors are likely to be present, and then flowing across the bed area to the exhaust. • exhaust air directed to outside or HEPA-filtered, if recirculated. • room monitored on initiation of use and at least daily when in use. • door kept closed at all times when not required for entry and exit. • If performing Aerosol generating Procedures : compulsory to perform in a Negative Pressure room <p><i>Please refer to Chapter 4: Isolation room</i></p>
<p>Personal Protective Equipment</p>	<p>N95 mask or Higher level respirator</p> <ul style="list-style-type: none"> • Appropriate fit test must be performed • Avoid touching the mask • Change if soiled / or failed fit test <p>Practice standard precaution at all times along with 5 moments of hand hygiene.</p> <p>Appropriate PPE for Contact Precaution if patient has indications</p>

Environmental Cleaning	As before
Equipment Handling	As before
Transporting patients	<ul style="list-style-type: none"> • Patient movement and transport from the room should be limited unless for essential purposes. • If a patient needs to be transported out of the room, inform the receiving department of the need for airborne precautions. • Healthcare personnel should wear an N95 mask or respirator during transportation of patients. • Patients should wear a surgical mask if tolerable and follow Respiratory Hygiene /Cough Etiquette in order to minimise the dispersal of droplet nuclei during transportation.

3.13 Translocation

1. Bacterial translocation is defined as the passage of viable bacteria from the gastrointestinal (GI) tract to extra-intestinal sites, such as the mesenteric lymph node (MLN) complex, liver, spleen, kidney, and bloodstream. This may promote the systemic spread of indigenous translocating bacteria to cause lethal sepsis.
2. Factors that predisposes to translocation
 - a. intestinal obstruction;
 - b. jaundice;
 - c. inflammatory bowel disease;
 - d. malignancy;
 - e. pre-operative total parenteral nutrition (TPN);
 - f. emergency surgery; and
 - g. gastric colonisation with microorganisms.
3. Measures to reduce bacterial translocation
 - Luminal nutrients rather than TPN
 - Measures that discourage bacterial overgrowth in the proximal gut.
 - Reduce the use of acid suppressing medications
 - Consider acidified enteral feeding
 - Judicious use of antibiotics(avoid broad spectrum antibiotics)

- Gut-specific nutrients and immune enhancing feeds, such as glutamine and arginine.
- Measures to improve splanchnic blood flow, dopexamine, inotropes and ischaemia-reperfusion injury (no evidence this improves mortality)
- Measures to control acute abdominal compartment syndrome may lead to a decrease in translocation
- Intra-operative bowel manipulation has been shown to adversely affect gut barrier function and increase bacterial translocation in humans
- Decrease the use of opiates in the critically ill when suitable alternatives are available
 - Opiate sparing protocols for analgesia are known to reduce nausea and vomiting, enhance transit times, preserve intestinal migratory motor complexes

Visitors

Patient with TB:

- Household contacts who have been exposed do not need to wear an N95 respirator.
- Visitors who are non-household contacts should be discouraged from visiting. They should be counselled about their risk and taught how to use an N95 respirator appropriately if they do visit.

Patient with varicella and measles:

- Household contacts who have been exposed do not need to wear N95 respirator. They should be assessed for presence of active infections before visiting.
- Visitors who are known to be immune or vaccinated do not need to wear an N95 respirator.

Visitors who are non-household contacts, not immune or vaccinated and have no history of varicella and measles should not visit.

4

ISOLATION ROOM

Introduction

Patients suspected or diagnosed with an infectious disease which is transmitted by droplets or airborne will be required to be placed in an isolation room to interrupt the transmission of microorganisms.

The isolation rooms can be part of a department or a ward or can be grouped into a dedicated ward or building.

4.1 Classification of Isolation room

The isolation rooms are classified into two main categories based on the basic principle of pressure controls which are:

- Airborne Infection Isolation Room (AIIR) and
- Protective Environment (PE) Room.

4.1.1 Airborne Infection Isolation Room (AIIR) (Negative Pressure Room)

The AIIR is commonly known as Negative Pressure Room. It refers to the negative pressure relationship between the patient's room and the corridor i.e.. the air pressure in the patient's room is more negative compared to the corridor (air shall flow from the corridor to the patient's room). This is to prevent infectious particles generated by the patient in the isolation room from spreading to other patients, HCWs and visitors. The room requires a ventilation system that shall not be shared with other rooms or areas.

AIIR is a suite made up of the patient's room and an en-suite bathroom with an anteroom. However, en-suite bathrooms are not required in specialized areas; e.g. intensive care unit, neonatal care unit, cardiac care unit.

4.1.2 Protective Environment Room (PE) (Positive Pressure Room)

PE room, commonly known as Positive Pressure Isolation Room whereby the air pressure in the patient's room is more positive than the corridor (air flow from the patient's room to the corridor). This is to protect the patient against infectious particles. These rooms are used to house suspected or infected patients who are severely immunocompromised. The PE is a room made up of patient's room and en-suite bathroom with an anteroom.

4.1.3 Contact Isolation Room

This type of room is for patients infected with MDROs or has food and water borne diseases. This room does not require special design measures for air-conditioning and ventilation systems.

Table 4.1 Summary of the basic differences between the AIIR and a PE Room.

	Airborne Infection Isolation Room (AIIR)	Protective Environment (PE Room)
Key Ventilation Criteria	Lower air pressure in the room than in the adjacent corridor.	Greater air pressure in the room than in the adjacent corridor.
Transmission based precaution	To prevent transmission of pathogens from AIIR to the outside environment.	To prevent transmission of pathogens from the outside environment to immunocompromised patients

Table 4.2: Functional Classification of Isolation Room

	Airborne Infection Isolation Room (AIIR)	Protective Environment (PE Room)
Examples of cases	Patients with: Tuberculosis, Chickenpox, Avian Flu, Severe Acute Respiratory Syndrome (SARS), measles etc.	Immunocompromised patients: Bone marrow or organ transplant recipients, severe burns, severe neutropenia, Allogeneic Hematopoietic Stem Cell Transplant etc.

Note: Alternating mode of ventilation shall not be permitted.

Anteroom

An Anteroom or 'airlock lobby', when attached to an Isolation room, functions as:

- A controlled area in which the transfer of supplies, equipment and persons can occur without contamination impacting on the surrounding health care areas
- A barrier against the potential loss of pressurisation
- Controls the entry or exit of contaminated air when the anteroom door is opened
- A controlled area where personal protective equipment (PPE) or clothing can be donned or removed prior to entry/exit of the isolated contamination area.
- Sinks should be available for hand washing.
- The Anteroom will require adequate space to allow for storage of Personal Protective Equipment (PPE) i.e.. gowns and gloves for protective isolation. Anterooms should not be shared between Isolation rooms.

Each isolation room should have an individual pressure regulator. *Dual function of positive and negative pressure regulator for an isolation room is not recommended. The faulty or malfunction of the link between both pressures can cause pressure imbalance. When rooms are not properly pressurised (positive or negative), airborne contaminants can escape putting the health of patients and staff at risk.



* Dual function of pressure regulator (both positive & negative) for an isolation room which shall not be permitted

Patients on isolation require special protection

- Family and visitors play a key role in infection prevention. Hand hygiene practice must be followed before entering and leaving the room.

- To assure safety for the patient and family/visitors, those entering the patient's room shall don the required personal protective equipment (PPE) as required for the type of isolation.
- Family and/or visitors' presence may be limited or minimized under certain circumstances. Examples include family or visitors who have a contagious illness or a known exposure to a communicable disease that may jeopardize the patient's health, those who are not able to wear PPE or maintain isolation precautions, etc.
- Children under the age of 12 are not allowed to visit.

4.2 Preparation of the AIIR before patient placement

- Ensure negative pressure system is functioning.
- Post signage on the door.
- Remove all non-essential furniture; the remaining furniture should be easy to clean, and should not conceal or retain dirt or moisture within or around it.
- Stock PPE supply and linen outside the isolation room/area (e.g. in the anteroom).
- Stock the sink area with suitable supplies for hand hygiene. Wall-mounted soap and disinfectant dispensers which are preferably touch free
- Storage for clean PPE
- Ensure the two-way communication system (e.g. intercom) should be functioning to enable patients or family members/visitors to communicate with HCWs in order to minimise the necessity for HCWs to enter the room/area.
- Place appropriate waste bags in the pedal operated bin.
- Place a puncture-proof container for sharps disposal inside the isolation room/area.
- Keep the patient's personal belongings to a minimum. Keep water pitchers and cups, tissue wipes, and all items necessary for attending to personal hygiene within patient's reach.
- Room should be dedicated with a stethoscope, thermometer, blood pressure cuff, and sphygmomanometer
- Any patient-care equipment that is required for use by other patients should be thoroughly cleaned and disinfected immediately after use.
- Place an appropriate container with a lid outside the door for non-disposable equipment that requires disinfection or sterilisation.
- Keep adequate equipment required for cleaning or disinfection inside the isolation room/area and ensure daily cleaning of the isolation room/area.

- Educational information on necessary precautions and procedures should be readily available and accessible for staffs, patients and visitors, while ensuring there is no breach of medical confidentiality.

4.3 Special Safety Design and Operational Consideration

The stringent monitoring of room pressurization via appropriate devices or verification mechanism(s) should be strictly adhered to in order to eliminate any possibilities of pressure scheme changes in the dedicated isolation room.

For design and engineering requirement, please refer to “*Guideline on Conceptual Design and Engineering Requirements for Isolation Room, Ministry of Health Malaysia, MOH/ESD/2017-01*”

4.4 Room Pressure Monitoring System

All isolation rooms require a permanently installed visual mechanisms to constantly monitor the pressure difference between the isolation room and the adjacent spaces when occupied by a patient.

The nursing care plan when caring for patient in the isolation room will include daily monitoring and documentation of room and anteroom pressures.

The maintenance staff shall ensure all related gauges and environmental parameter indicators at the isolation room are inspected, serviced and calibrated as per stipulated frequency for optimum operation of the room. Records shall be kept for evidence and reference.

4.5 Verifying Room Pressure

The pressure readings in the isolation room shall be verified on a daily basis by the HCWs to ensure that the systems are functioning as per designed or standard requirements. Any deviation or inconsistency of readings shall be immediately reported to the maintenance staff.

CLINICAL PRACTICE

5.1 Aseptic Technique

The aseptic technique is a method to prevent transmission of microorganisms from various sources to a patient by creating a microorganism-free environment, maintaining sterility of instruments and preventing microbial contamination during various clinical procedures performed on a patient.

5.1.1 Non touch technique

- Non touch technique is a method of performing a procedure without directly touching any other surface that might come into contact.
- It is essential to ensure that hands, even though they have been washed, do not contaminate the sterile equipment or the patient.
- This can be achieved either by the use of forceps or wearing sterile gloves.
- Contact with the non-gloved hand and any other non-sterilized object renders the instrument or item non-sterile.
- Work processes need to be coordinated so that the sterile or disinfected item or instrument does not come into contact with non-sterile items.

5.1.2 Minimizing microorganisms on hands by hand hygiene

(Please refer section on hand hygiene)

- Hand hygiene is a must before and after performing any clinical procedure. This practice maintains the cleanliness of the health care workers' hands at all times.

5.1.3 Rendering the Hand Sterile by Wearing Sterile Gloves

- Sterilized gloves are worn to render the hand sterile.
- During the gloving process, touch only the inside surface of the glove with the non-gloved hand. The outside of the glove can be touched with the gloved hand.

- Once gloved, do not touch non-sterile areas or articles with the gloved hand. **Remember that the patient's skin is non-sterile.**
- If the glove is punctured or torn, replace it.
- When working alone, perform tasks that do not require a sterile hand first before gloving. (For example, when preparing sets/instruments for a procedure, open the set and put in additional items or lotions first. Open the outer layer of the gloves packet before washing the hand).
- In most instances, an assistant/partner is recommended to perform tasks that do not require a sterile hand.
- When one hand is required to perform a task which requires contact with a non-sterile object or surface, consciously identify the contaminated hand and perform procedures with the other hand. These situations include:
 - When performing urinary catheterisation; hold the labia minora or prepuce of penis with the non-dominant hand. Cleanse the urethra and insert the catheter with the dominant sterile hand.
 - When performing laryngeal suction; (e.g. in a patient with a tracheostomy) hold the non-sterile sucker tubing with the left hand and the sterile suction catheter with the right hand.
 - When performing tracheo-bronchial suction on a ventilated patient; the aseptic technique is possible only if two care providers perform the task. One person disconnects and reconnects the ventilator tubing to the endotracheal /tracheostomy tube. The other person performs the suction with a sterile catheter.

5.1.4 Minimizing bacteria at entry points

- The presence of bacteria depends on the site where the procedure is to be performed.
- The patient's skin harbour commensals (e.g. *Staphylococcus epidermidis*), which are harmless on the skin surface but may cause infection if it enters the bloodstream.
- Use antiseptic for skin preparation prior to sterile procedures.

5.1.5 Creating a sterile field

- There should be a sterile area within which instruments used for the intended procedure can be placed without risk of it being contaminated.



- A sterile field is created by covering the patient's body and work surfaces with drapes made of sterilized fabric or synthetic sheets. It is important for the sterile field to be wide enough to accommodate the instruments used and for the HCW to perform his/ her tasks.
- The amount of skin exposed should be as minimum as possible.
- The HCW is allowed to be in contact with the sterile field if a sterile gown is worn. If only a glove is worn then the rest of the body should not come into contact with the sterile field.

5.1.6 Maintaining sterility of instruments / disposable items during a procedure

- The non-touch technique is also used to ensure that instruments or items remain sterile during a procedure. The person opening packets/ envelopes must ensure that the inside of the packet is not touched.
- Transfer the instrument by letting it drop on to the sterile field. Another method is for the person receiving the item to grasp the item or the inside package from the packet with a gloved hand or sterile forceps without touching the exterior of the packet.
- The entire sterile instruments/disposable items (such as lines and catheters) should lie within a sterile field. Special care must be taken when using long lines or wires e.g. guide wires.
- Problems arise when the sterile catheter or tubes need to be connected to non-sterile connectors. Below are some of the situations when some of these problems occur and how they can be resolved:
 - When inserting a central line; introduce the IV catheter and all connecting tubes into the sterile field. After the catheter is inserted, pass the end of the intravenous tubing (used to puncture the IV solution bag) to the assistant.
 - The assistant connects the tubing to the bag and the fluid is run in to prime the line. The other end remains sterile in the sterile field and is then connected to the intravenous catheter.
 - A similar technique is used when inserting chest drains, peritoneal dialysis catheters and urinary catheter. Place all tubes and containers into the sterile field.
 - The person performing the procedure should secure the connections before passing the containers (underwater seal bottles /urine containers /dialysate bags) to the assistant.

5.2 Enteral Nutrition

5.2.1 Introduction

Enteral Nutrition is the provision of nutrients through the gastrointestinal tract, which includes feeding given via tube and oral route (Refer Figure 5.1). Enteral nutrition preparation and formulation is very complex and should be individualised according to patient's underlying conditions and needs.

Complications resulting from enteral nutrition are not uncommon among hospitalised patients which may occur due to:

- Contaminated formulas that may cause gastrointestinal complications such as diarrhoea and vomiting.
- Colonisation of feeding tubes that may cause tube occlusion and degradation whilst colonisation of the stomach has been associated with healthcare associated infections.

Therefore, minimizing potential microbial contamination is crucial to ensure patients achieve optimal nutrition and prevent serious infections or complications related to enteral nutrition.

Contamination of enteral formula can occur at any point throughout the production, preparation, storage, administration process, (Refer Figure 5.2) and of the formula or the design of feeding system used. Closed enteral formula systems (in bags or rigid containers) are preferred to the open systems (in cans or bottles) due to the minimal microbial content.

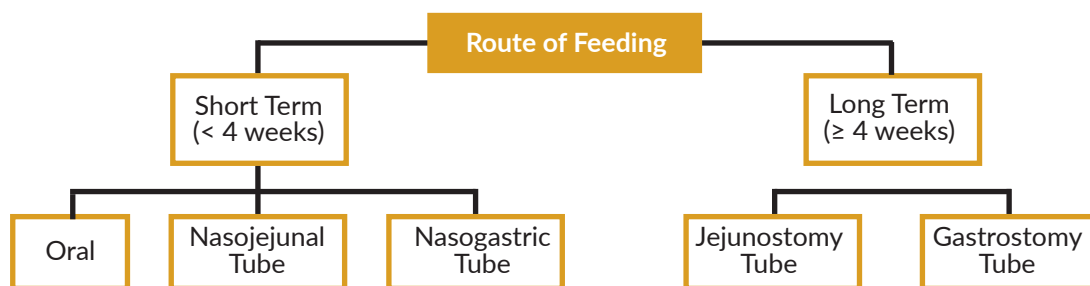
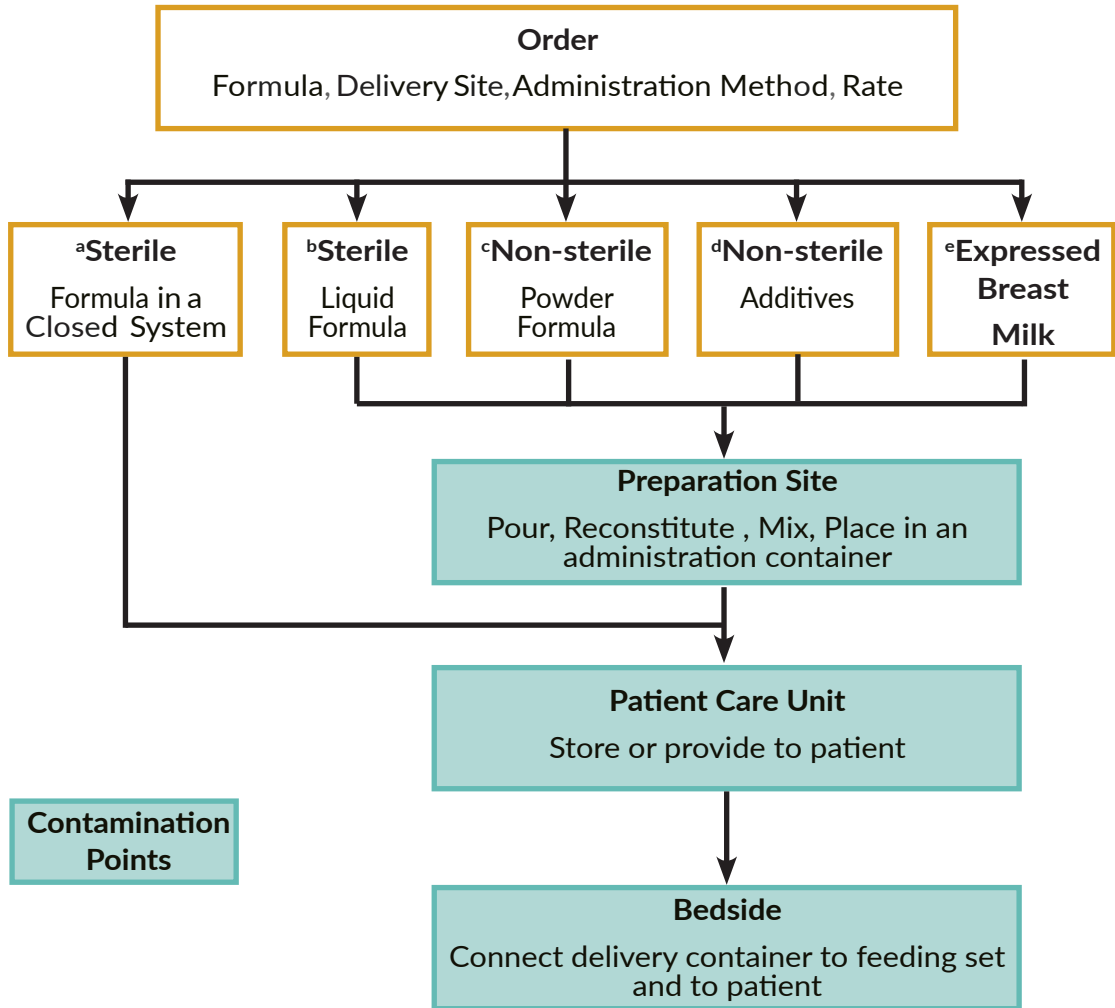

Figure 5.1: Route of Feeding



^a -Hang Time 24 to 48 hours

^b -Hang Time 4 to 8 hours

^{c, d, e} -Hang Time 4 hours

Figure 5.2: Hang Time and Potential Points for Contamination

5.2.2 Causes of Microbial Contamination and Preventive Measures

Causes of Contamination	Preventive Measures
<p>Personnel</p>	<ol style="list-style-type: none"> 1. Health care workers with active diarrhoea should not handle enteral formula until they have been cleared. 2. Use of gloves when handling enteral formula is recommended. 3. Open skin lesions should be covered to prevent potential contamination with bacteria. 4. Enteral formula should be prepared in a clean environment. 5. All personnel involved should be trained for the tasks and follow accepted best practices.
<p>Physical facility</p>	<ol style="list-style-type: none"> 1. There should be a room equipped with the necessary facilities and designed for the purpose of packaging or preparing enteral formula. 2. The preparation area should be clean and hand washing facilities with stainless steel sink should be made available. 3. The area should be well ventilated.
<p>Formula preparation <i>Adding water or other substances, or using procedures that increases handling of formulas or administration system increases the potential contamination</i></p>	<ol style="list-style-type: none"> 1. Use commercial formulas and avoid foods which are blended. Sterile, liquid enteral formula should be used in preference to powdered, reconstituted formulas whenever possible. 2. Use boiled water for formula reconstitution and medication dilution. 3. Avoid adding colorants, medications or other substances directly to formula.



	<ol style="list-style-type: none"> 4. Use full strength formula. For gastrointestinal intolerance, reduce administration rate instead of diluting the formula. Reduce handling by using closed feeding system. 5. Label product, date and time of preparation on the container. 6. For neonates preparation for enteral formula, refer WHO guidelines for PIF hospital setting (2008)
<p>Touch contamination during preparation</p>	<ol style="list-style-type: none"> 1. Practice hand hygiene before handling formula or administration system. 2. Use disposable gloves. 3. Sanitise all equipment and surfaces used for formula preparation. 4. When using decanted formula, sanitise the container before opening.
<p>Unsafe storage and transportation</p> <p><i>Even low-level contamination can grow logarithmically in nutrient-rich solutions at warm temperatures</i></p>	<ol style="list-style-type: none"> 1. Store unopened commercial liquid enteral formula under controlled (avoid direct sunlight, dry area, less than 23oC) conditions. Recommended to have air-conditioned room for storage. 2. Maintain a rapid enteral formula inventory turnover well within the product's expiration date. 3. Keep prepared formula at suitable temperature until ready for use. Freshly prepared formula is a better option. 4. Cover, label and refrigerate opened and reconstituted formulas. Discard after 24 hours if unused. Do not allow refrigerated formulas to sit at room temperature for more than 20 minutes before feeding. 5. Do not freeze or overheat the formula. 6. Do not reheat formula with microwave oven.



<p>Administration and prolonged hang time</p> <p><i>Regardless of administration system, all tube-feeding formulas have risk of microbial growth.</i></p> <p><i>Prolonged hang time is associated with unacceptable microbial levels</i></p>	<ol style="list-style-type: none"> 1. Limit hang time (refer to figure 5.2) 2. When using decanted formula, allow feeding to empty completely and rinse before adding fresh formula. 3. Avoid topping up freshly prepared formula until all the previous formula in feeding bag is completely administered. 4. Use feeding tube with appropriate size to avoid clogging of enteral formula. Flush feeding tube with clean water regularly. 5. Use clean technique to add medication to the feeding tube if cannot be given by other route. Avoid mixing medications together 6. Withhold feeding, flush tube with water to check for tube patency prior to administration of medications. 7. Administer medication using a clean oral syringe. 8. Resume feeding immediately for continuous feeding.
<p>Touch contamination during administration</p>	<ol style="list-style-type: none"> 1. Practice hand hygiene before handling feeding systems. 2. Reduce handling by using pre-filled containers. 3. Reduce the number of times that a delivery system must be disconnected. 4. Use clean technique when refilling or changing feeding containers. 5. Assemble feeding systems on a clean, dry, disinfected surface (not on the patient's bed)
<p>Reuse of feeding sets</p>	<ol style="list-style-type: none"> 1. Feeding sets for closed system should be changed per manufacturer's guidelines. 2. Feeding sets for open system should be changed every 24 hours. 3. Feeding sets for expressed breast milk should be changed every 4 hours. 4. Discard feeding sets and containers according to instructions. Prolonged use of feeding systems 5. causes significant contamination.



Microbial analysis may be performed in the following conditions:

- As part of the investigation of an outbreak
- When the food is suspected as the potential source of infection

5.3 Parenteral Nutrition

5.3.1 Introduction

Infection related complications may be a major threat to patients receiving centrally or peripherally infused parenteral nutrition (PN). In addition to patient factors such as compromised immunity, infection may result from insertion of any IV administration device. Organisms commonly known to cause infections are staphylococci (the most common and tend to be the most pathogenic), enterococci and *Candida* spp.

The difference between PN and other modes of intravascular therapy are as follows:

- a) PN tubes usually remain in place much longer than other catheters
- b) PN solutions are a good medium for bacterial and fungal growth

The underlying disease of the patient may increase the risk of acquiring Health Care Associated Infections (HCAI).

Contamination of the PN can occur:

- During the preparation of PN
- At the time of insertion of the catheter
- As a result of manipulation of catheter
- Due to prolonged hanging time

The following factors should be followed in the preparation of PN,

(Please refer to ASPEN 2013 Safety Consensus)

- Prepare PN strictly under aseptic technique
- A clean room environment is required.
- Compounding should be prepared by trained staff
- Personal Protective Equipment (PPE) should be worn before entering the clean room.

Catheter care-related factors

(Please refer to Chapter 6: Prevention of HCAI)

1. **Selection of catheter insertion site**
 - a) The risk of catheter-related infection can be reduced by using specialized catheters such as implant catheter, single lumen catheter and peripheral access catheter
 - b) If triple lumen catheter port is used for PN administration, a single lumen must be dedicated for PN only. This should be labelled and dated. There should not be any entries to the PN line except for lipid infusions.
2. **Procedure for insertion of catheter**
(Please refer to Chapter 6: Prevention of HCAI)
3. **Surveillance of the PN line**
 - a) PN solutions hang time:
 - Compounded for 24 hours
 - Ready to use (commercial preparation) for 48 hours
 - b) Evaluate the patient at least 8 hourly for evidence of cannula-related complications
 - c) The patient should be monitored for complications which include:
 - Signs of local infection at the insertion site
 - Fever without obvious source
 - Symptoms of local bloodstream infection
 - Allergic type reaction.

If the above complications are present or suspected, the doctor in-charge and pharmacist should be notified.
 - d) Surveillance culture of PN solution should be performed routinely after the preparation.
 - e) Surveillance cultures of PN devices should not be performed routinely.
4. **Replacement of PN tubing and filters**
 - a) PN solution shall be infused through a filter appropriate for the type of formulation. Administration tubing should be attached to PN containers using sterile technique, immediately prior to initiating the infusion.
 - b) Filters are manufactured for single patient use and should be changed according to the guidelines by the manufacturer. The filters available are as follows :
 - Filter 0.2 micron for 24-hour use

- Filter 0.2 micron for 96-hour use
- Filter 1.2 micron for 24-hour use

However, the tubing and bag must be changed every 24 hours.

- c) During compounding at pharmacy; due to the potential of contamination and subsequent release of endotoxin, filters should not be primed with PN solution in advance.
 - d) Change the tubing and filter if the infusion rate is slow or poor. Flushing or irrigation of the system should be avoided.
 - e) In between changes of the components, the IV system should be maintained as a closed system as much as possible.
5. **Nursing considerations for PN**
- a) PN solution that is not opened nor used should be returned to Pharmacy Unit
 - b) PN solution shall be maintained at the prescribed rate:
 - Correct pump settings shall be monitored at regular intervals.
 - PN infusion rate shall not be adjusted and to discard the leftover solution at 24 hours.
 - If additional fluid therapy is required it should be given via a separate infusion line.
 - PN infusion should not be interrupted for routine care or patient transport for diagnostic studies.
 - c) Monitor vital signs, electrolyte, glucose monitoring and fluid input / output
 - d) In the event that a patient with PN has fever of unknown source, removal of the PN catheter may be considered.
6. **Storage**
- a) If the PN solution is not being used immediately, store the PN solutions in the refrigerator (recommended temperature is between 20C-80C). The temperature of the PN infusion should be brought to room temperature one hour prior to the infusion.
 - b) PN solution should be returned to the Pharmacy when:
 - Cloudy or particulate matter is present in the solution
 - Orders for the PN administration are modified / discontinued

5.4 Wound Care

The need for dressing or wound care depends on the type of wound which includes incision wounds, abrasions, pressure injuries, ulcers, and wounds at drain sites.

The attending physician/HCW may apply different types of wound dressings for each type of wound. However, the size of the dressing should be large enough to cover and protect the wound site and the surrounding tissue. It should allow air circulation to the skin, secured to prevent slippage and is comfortable to the patient.

Extra caution by the HCW is necessary when dealing with infected wounds, especially when it involves MDRO.

General principles of wound care

1. Standard Precaution:
 - a) Hand hygiene
 - b) Sterile glove
 - c) Apron

Note: Gown should be used when dealing with wound infected by MDRO or during procedures which may give rise to possibility of splash

2. Comprehensive assessment of wound in a patient.
 - a) General assessment:
 - b) identify contributing factors and underlying cause
 - c) Local assessment of the wound (*refer to National Wound Care Manual 2014*)
 - Type of wound (e.g. leg. ulcer, pressure injury)
 - Aetiology (e.g. venous insufficiency, pressure)
 - Duration of wound
 - Anatomical location
 - Wound dimensions
 - Clinical characteristics of wound bed (e.g. aggranulation, granulation, hypergranulation, epithelialisation, slough, necrotic/eschar, exposed bone or tendon, foreign body, fistula).
 - Wound edge characteristics (e.g. raised, rolled, undermined, sloping, everted)
 - Periwound and surrounding skin characteristics (e.g. erythema, oedema, induration, maceration, desiccation, dermatitis/eczema, callus, hyperkeratosis, changes in pigmentation).

- Exudate, for example:
 - Type (e.g. serous, haemoserous, sanguineous, seropurulent, purulent)
 - Consistency (e.g. thick or thin)
 - Amount
 - Odour
- Signs and symptoms of inflammation or infection.
- Digital photography or technologies may be used to document wound size and appearance in conjunction with above assessments.

3. Dressing Technique

Dressing technique is applicable to all types of wound

- a) Perform hand hygiene and wear appropriate PPE.
- b) Use non sterile clean glove to remove previous dressing.
- c) To perform hand hygiene again and put on sterile glove before the start of new dressing.
- d) Practice a 'non-touch' dressing technique if possible. All instruments used during wound dressing must be sterile.
- e) Use sterile water as a cleansing solution unless other solution is recommended by the doctor.
- f) Perform the wound dressing according to the sequence below:
 - Swab from clean area to dirty area. Use one (1) swab for each stroke.
 - Remove debris, scabs, slough, biofilm when necessary.
 - Irrigate with sterile water / saline solution if required.
 - Clean the periwound area thoroughly.
- g) Cover the entire wound to prevent bacterial contamination. Use non-allergenic dressing to promote wound healing.
- h) Used gloves, apron and soiled dressing must be properly disposed into the clinical waste plastic bag.
Note: For MDRO patients, the clinical waste should be disposed in the designated clinical waste bin.
- i) Wound care in the ward should be.g.in with the uninfected wound first, then followed by the infected wound. Patients infected with MDRO should be placed last on the list to undergo the procedure.

4. Environment

Maintain a clean environment to minimise dust. High dusting or vacuum cleaning should be completed an hour before the dressing procedure begins. Fans should be switched off.

5. Principles of Management
 - a) For full wound management refer to *National Wound Care Manual 2014*.
 - b) Wound swab for culture is recommended for infected wound.

5.5 Blood and Blood Component Transfusion

Blood transfusion has saved many lives. The blood and blood components shall be screened negative for appropriate transfusion-transmitted infections and subjected to compatibility test prior to transfusion.

5.5.1 General Principles

All blood and blood products should be considered as potentially infectious and need to be handled cautiously. Common organisms that can be transmitted through blood transfusion are Hepatitis B virus, Hepatitis C virus, HIV, and malarial parasites among others. The basis of precautionary measures taken prior or during the blood and blood components transfusion involves procedures to protect portal entry, thus preventing:

- i. Access of microorganism into the host tissue.
- ii. Cross contamination

Note: Medications should not be added intravenously with the blood or blood components.

5.5.2 Transfusion practices (transport, storage administration, and disposal)

- a) Blood and blood components should be kept in appropriate blood box as recommended by the blood bank during transportation from the blood bank to the ward.
 - Transfusion of red cells must be started within 30 minutes of removing them from refrigerator (stored at 2-6°C) and should be completed within four hours.
 - Platelet and plasma must be transfused immediately.
- b) Inspect the supplied units of blood and blood components for date of expiry, cracks and leaks. Do not use leaking blood bag and immediately return it to the blood bank.
- c) Ensure that the correct blood and blood components is given to the intended patient. Follow local procedure manual for patient identification.

- d) Insert intravenous line using aseptic technique.
- e) Choose a site on an upper extremity which will minimise patient discomfort and restriction of movement. **Avoid groin, lower extremities and bony prominences because these sites have higher risk of infection.**
- f) Label date and time of onset of transfusion.
- g) Monitor the patient's pulse rate, temperature and blood pressure during transfusion. STOP transfusion immediately if any suspected adverse reaction including fever and hypotension occurs; as this could be early signs of septic shock.
 - After completion of blood transfusion, the used blood bags and intravenous giving set should be tightly secured and put aside into a transparent bag. DO NOT disconnect giving set from the blood bag. Send it immediately to the blood bank for proper disposal.
 - DO NOT REUSE INTRAVENOUS GIVING SET for the next/subsequent fluid transfusion.

6

PREVENTION OF HEALTHCARE ASSOCIATED INFECTIONS

6.1 Catheter Associated Urinary Tract Infection (CAUTI)

6.1.1 Introduction

Urinary tract infection (UTI) is a common type of HCAI, accounting for 20% of all infections in Malaysian hospitals. In addition, several studies have reported that about 80% of UTIs occur following instrumentation, primarily catheterisation. The usually benign nature of catheter-associated UTIs and the perception that they are easily treated by antibiotics may inhibit aggressive measures for both their prevention and their recognition.

6.1.2 Indications for Catheterization

Placement of an indwelling catheter should be performed only when indicated. It should be removed as soon as possible.

The accepted indications for catheterisation are:

1. Patient with acute urinary retention or bladder outlet obstruction.
2. Need for accurate measurement for urinary output in critically ill patients
3. Perioperative use for selected surgical procedures:
 - a. Patients undergoing urologic surgery or other surgery on contiguous structures of the genitourinary tract.
 - b. Anticipated prolonged duration of surgery (Catheters inserted for this reason should be removed in OT recovery area/ as soon as possible)
 - c. Patients anticipated to receive large volume infusions or diuretics during surgery
 - d. Need for intra-operative monitoring of urinary output.
4. Patient who require prolonged immobilization (e.g. Potentially unstable thoracic or lumbar spine, multiple trauma injuries such as pelvic or spinal fractures)

5. To improve comfort for end of life care if needed.

Notes:

- a. Avoid catheterisation as the main management in patients with urinary incontinence
- b. Minimise use in all patients, particularly those at higher risk of CAUTI (women, elderly, impaired immunity) e.g. elderly patient with benign prostatic hypertrophy.
- c. In patients with urinary incontinence who have sacral sore or perineal sore, try to use condom catheter if possible.

6.1.3 Recommendations for the prevention of CAUTI

1. Insert catheters only for appropriate indications
2. Leave catheters in place only as long as needed.
3. Trained personnel should insert and maintain the catheters.
4. Insert catheters using aseptic technique and sterile equipment.
5. Following aseptic insertion, maintain a closed drainage system.
6. Maintain unobstructed urine flow.
7. Adhere to Hand hygiene and Standard Precautions

Notes;

For selected patients, other methods of urinary drainage such as condom catheter drainage, suprapubic catheterisation, and intermittent urethral catheterisation may be more appropriate.

6.1.4 Catheter Insertion

- Catheters should be inserted using aseptic technique and sterile equipment.
- Catheters should be inserted using aseptic technique and sterile equipment.
- Gloves, drape, sponges, sterile water solution for peri-urethral cleaning and a single-use packet of lubricant should be used for insertion.
- In order to minimise urethral trauma, a small size and patent catheter should be used.
- Indwelling catheters should be properly secured after insertion.

6.1.5 Closed Sterile Drainage

- The catheter collection system should remain closed and not be opened unless required for diagnostic or therapeutic reasons e.g. irrigation.

- If break in aseptic technique, disconnection, or leakage occur, the collecting system should be replaced using aseptic technique after disinfecting the catheter tubing junction.

6.1.6 Irrigation

- Continuous irrigation should be avoided unless indicated (e.g. after prostatic or bladder surgery).
- Continuous irrigation of the bladder with antimicrobials has not proven to be useful and should not be performed as a routine infection prevention measure.
- The catheter-tubing junction should be disinfected before disconnection.
- If the catheter becomes obstructed, the catheter should be changed.

6.1.7 Specimen Collection

- If a small volume of fresh urine are needed for examination, the distal end of the catheter, or preferably the sampling port if present, should be cleansed with a disinfectant, and urine then aspirated with a sterile needle and syringe.
- Larger volume of urine for special analyses should be obtained aseptically from the drainage bag but this should not be used for urine culture.

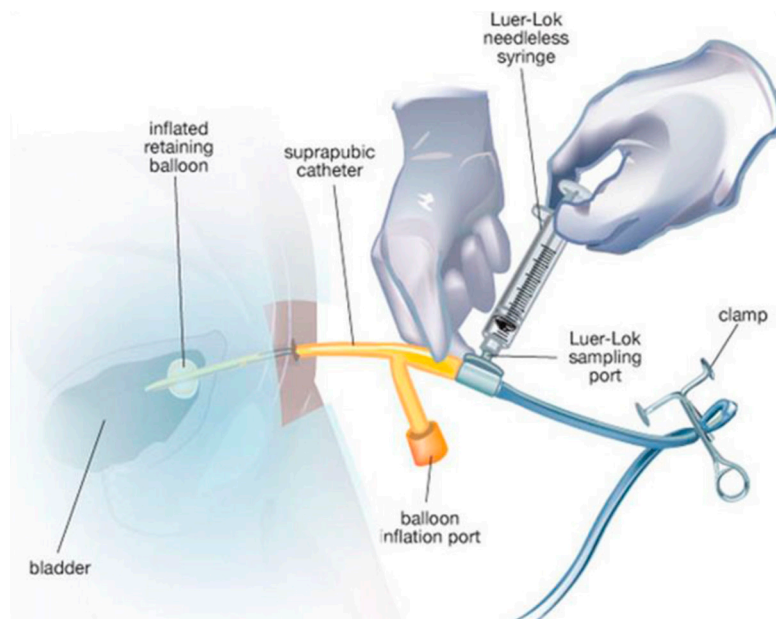

Figure 6.1: A correct method of urine specimen collection

Figure 6.2: Specimen should not be collected from the tap from the main collecting chamber of the catheter bag as colonisation and multiplication of bacteria within the stagnant urine or around the drainage tap may have occurred.



6.1.8 Urinary Flow

- Urine flow should be maintained and should be checked several times a day to ensure that the catheter is not blocked.
- Collecting bags should always be kept below the level of the bladder and it should not touch the floor.

6.1.9 Meatal Care

- Clean the urethral meatal area after each bowel movement or when soiled.

6.1.10 Catheter Change Interval

There is no strong evidence to suggest that interval of catheter change will reduce CAUTI incidence.

- The timing of catheter change should be individualized.
- Indications for changing the catheter include obstruction either by encrustation or mucus, symptomatic infection, or leakage around the catheter.
- Latex catheters are prone to encrustation and require more frequent changes than silicone or hydrogel-coated latex.

6.1.11 Bacteriologic Monitoring

- The value of regular bacteriologic monitoring of catheterized patients as an infection control measure has not been established and is not recommended.

6.2 Surgical Site Infection (SSI)

6.2.1 Microbiology of SSI

The pathogens isolated from SSIs have not changed markedly. The common source of pathogens is the endogenous flora of the patient's skin, mucous membranes, or hollow viscera. Therefore, the pathogens isolated from infection differ, primarily depending on the type of surgical procedure. In clean surgical procedures, in which the gastrointestinal, gynaecologic, and respiratory tracts have not been entered, *Staphylococcus aureus* from the exogenous environment or patient's skin flora is the usual cause of infection. In other categories of surgical procedures, including clean contaminated, contaminated, and dirty, the polymicrobial aerobic and anaerobic flora closely resembling the normal endogenous microflora of the surgically excised organ are the most frequently isolated pathogens.

Other sources of SSI pathogens are from distant foci such as in patients with prosthesis or implant placed during the surgery, surgical personnel, operating environment, surgical tools, instruments, and materials brought to the field during an operation.

6.2.2 Surgical site infection prevention guidelines

An SSI prevention measure can be defined as an action or set of actions intentionally taken to reduce the risk of an SSI. Many measures are directed at reducing opportunities for microbial contamination of the patient's tissues or sterile surgical instruments; others are considered as adjunctive, such as using antibiotics prophylaxis or avoiding unnecessary traumatic tissue dissection.

6.2.3 Preoperative measures

6.2.3.1 Preparation of the patient:

1. Whenever possible, identify and treat all infections remote to the surgical site before elective operation and postpone elective surgeries on patients with remote site infections until the infection has resolved.
2. As far as possible shorten the pre-operation hospital stay.
3. Do not remove hair preoperatively unless the hair at or around the incision site will interfere with the operation.
4. If hair needs to be removed, it is done just prior to the operation, preferably using electric clippers and not razor blade.

5. Adequate control of blood glucose levels in all diabetic patients. Aim the blood glucose level at < 200mg/dl (11mmol/l)
6. Encourage cessation of smoking (cigarettes, cigars, pipes, or any other form of tobacco consumption) at least 30 days prior to the surgery.
7. Do not withhold necessary blood products transfusion
8. Encourage patients to shower or bathe the night before the operative day. Gross contamination around and at the incision site should be thoroughly cleaned.
9. It is preferable and advisable to:
 - a. Taper or discontinue systemic steroid use (when medically permissible).
 - b. Improve patients' nutrition status prior to the surgery.
10. Each surgical discipline should provide specific procedure-related pre-operative preparation e.g. bowel prep in colorectal surgery.

6.2.3.2 Surgical team members

1. Keep nails short and do not wear artificial nails.
2. Do not wear hand or arm jewellery.
3. Clean underneath each fingernail prior to performing the first surgical scrub of the day.
4. Perform a preoperative surgical scrub for at least 2 to 5 minutes using an appropriate antiseptic (Alcohol-based antiseptic).
5. After performing the surgical scrub, keep hands up and away from body (elbow in flex position) so that water runs from tips of the fingers toward the elbow. Dry hand with sterile towel and don a sterile gown and gloves.
6. Limit the number of surgical team members in the OT.
7. Provide Continuous Professional Development (CPD) on Infection prevention,
8. SSI and other appropriate topic for the hospital staff especially for OT and surgical-based ward staff.

6.2.3.3 Management of infected or colonized surgical personnel

1. Educate and encourage surgical personnel who have signs and symptoms of a transmissible infectious illness to report conditions promptly to their supervisors who have the authority to restrict or even remove personnel from duty.

2. Develop well-defined policies concerning patient-care responsibilities when personnel have potentially transmissible infectious conditions. These policies should govern work restriction and clearance to resume work after an illness that required work restriction.
3. Obtain appropriate cultures from, and exclude from duty, surgical personnel who have draining skin lesions until infection has been ruled out or personnel have received adequate therapy and infection has resolved.
4. Do not routinely exclude surgical personnel who are colonized with organisms such as *Staphylococcus aureus* (nose, hands, or other body site) or group A *Streptococcus*, unless such personnel have been linked epidemiologically to dissemination of the organism in the healthcare setting.
5. Adhere to the CDC recommendations for Prevention of HIV and HBV Transmission during Invasive Procedures (Table 6.1) and HIV Infection Guide Book from MOH Clinical Practice Guidelines.

Table 6.1: CDC recommendations for prevention of HIV and HBV transmission during invasive procedures

1. Health care workers with exudative lesions or weeping dermatitis should cover any unprotected skin, or they should not provide patient care until the damaged skin has healed..
2. Hands should be washed after every patient contact.
3. Health care workers should wear gloves when contact with blood or body substances is anticipated; double gloves should be used during operative procedures; hands should be washed after gloves are remove.
4. Gowns, plastic aprons, or both should be worn when soiling of clothing is anticipated.
5. Mask and protective eyewear or face shield should be worn if aerosolisation or splattering of blood or body substances is expected.
6. Resuscitation devices should be used to minimise the need for mouth-to-mouth resuscitation.



7. Disposable containers should be used to dispose of needles and sharp instruments.
8. Avoid accidents and self-wounding with sharp instruments by following these measures:
 - Do not recap needles.
 - Use needleless systems when possible.
 - Use cautery and stapling devices when possible.
 - Pass sharp instruments in metal tray during operative procedures.
9. In case of an accidental spill of blood or body substance on skin or mucous membranes, do the following:
 - Rinse the site immediately and thoroughly under water.
 - Wash the site with soap and water.
 - Document the incident.
10. Blood specimens from all patients should be considered hazardous at all times.
11. Prompt attention should be given to spills of blood or body substances, which should be cleaned with an appropriate disinfectant.

6.2.4 Antimicrobial prophylaxis

1. Administer a prophylactic antibiotic agent only when indicated, and select it based on its efficacy against the most common pathogens causing SSI for a specific operation, and also adhere to MOH Antibiotic Guidelines.
2. Administer by IV route the initial dose of prophylactic antibiotic agent preferably within 30 minutes (for beta-lactams) or 60 min (for glycopeptides) prior to incision
3. Before elective colorectal operations, mechanically prepare the colon by use of enemas and cathartic agents and administer appropriate antimicrobial agents. (Refer to National Antibiotic Guidelines)
4. Administer the appropriate parenteral prophylactic antimicrobial agents before skin incision in all caesarean section procedures.
5. Application of antimicrobial agents (e.g. ointment, solution or powders) to the surgical incision is not recommended for prevention of SSI.

6. Patients undergoing cardiothoracic surgery with known nasal carriage of *Staphylococcus aureus* should receive perioperative intranasal application of mupirocin 2% ointment with or without a combination of CHG body wash.

6.2.4 Intra-operative measures

6.2.4.1 Operation Theatre (OT) environment

1. The OT should be maintained under positive pressure ventilation
2. Maintain adequate air exchanges
3. Filter all air, re-circulated and fresh air, through the appropriate recommended filters.
4. Maintain optimum room temperature according to standard parameters.
5. Keep OR room doors closed except as needed for passage of equipment, personnel, and the patient.
6. Limit the number of personnel entering and also the movement of personnel in the OT.
7. Consider performing implant operations in OT supplied with ultraclean air.

(Please refer to Chapter 7: Infection Control in Specific Healthcare setting, Operation Theatre and Chapter 12: Environment)

6.2.4.2 Procedure for Cleaning Operating Rooms In-between Cases

1. Prepare fresh disinfectant solution according to manufacturer's instructions.
2. Clean hands and put on gloves.
3. Collect and remove waste.
4. Collect and remove all soiled linen.
5. Remove gloves and perform hand hygiene.
6. Use a cloth wet with hospital-grade disinfectant solution to clean and disinfect horizontal surfaces that have come in contact with a patient or body fluids, including tops of surgical lights, blood pressure cuffs, tourniquets and leads.
7. Clean electronic equipment (i.e. monitors) according to manufacturer's instructions.
8. Clean equipment such as X-ray machines and compressed gas tanks from the operating room prior to leaving.
9. Clean suction canisters, reflective portion of surgical lights.

10. Clean top and sides of mattress, turn over and clean underside.
11. Clean floors. (*Refer to Chapter 12 Environment*)
12. Insert new waste liner bags.
13. When cleaning is complete, remove gloves and perform hand hygiene.
14. Place a cautionary 'Wet Floor' sign at the entrance to the room

6.2.4.3 Cleaning and disinfection of environmental surfaces

1. When visible soiling or contamination with blood or other body fluids of surfaces or equipment occurs during an operation, use approved hospital disinfectant to clean the affected areas before the next operation.
2. Do not perform special cleaning or closing of OT after contaminated or dirty operation.
3. Do not use tacky mats at the entrance to the OT suite or individual
4. OTs for infection control.
5. Wet vacuum the OT floor after the last operation of the day or night with an approved hospital disinfectant.

6.2.5 Microbiological sampling

Routine environmental sampling of the OT is not recommended. Perform microbiologic sampling of OT environment surfaces or air only as part of an epidemiological investigation, or when there is gross violation of the OT sterility.

(Please refer Chapter 7: Infection Control in Specific Healthcare setting, Operation Theatre)

6.2.6 Sterilization and disinfection of surgical and other medical instruments

1. Critical items

Instruments or objects that enter directly into the vascular system or sterile areas of the body. These items should be sterilised according to the recommended approved sterilisation methods; such as steam under pressure, dry heat, ethylene oxide, or other approved methods.

Flash sterilisation should only be used in emergency situations with the condition that the instruments must be already manually cleaned, decontaminated, and properly arranged in the container before sterilisation. Implantables should not be flash sterilized.

2. **Semi-critical items**

Instruments or objects that come into contact with mucous membranes or skin that is not intact (bronchoscopes and gastroscopes), such items generally require high-level disinfection that kills all microorganisms except bacterial spores. The approved disinfectants are glutaraldehyde 2%, and ophthalmaldehyde (OPA) which is a newer agent approved by FDA. In order to achieve high-level disinfection, make sure that the internal and external surfaces and channels should come into contact with the disinfecting agent for a minimum of 20 minutes.

3. **Non-critical items**

Instruments or objects that come in contact with intact skin (e.g. blood pressure cuffs). They generally require only washing or scrubbing with a detergent and warm water or disinfection agents such as 70% alcohol.

Reuse of single-use medical devices is not encouraged although the implied cost is a major concern.

6.2.7 Surgical attire and drapes

1. The mask must fully cover the mouth and nose when entering the OT if an operation is about to be.g.in or already under way, or when sterile instruments are exposed. The mask must be worn throughout the operation.
2. Wear a cap or hood to fully cover hair on the head and face when entering the OT.
3. A scrub-surgical team member must wear sterile gloves. Put on gloves after donning a sterile gown.
4. Use surgical gowns and drapes that are effective barriers when wet.
5. Change scrub suits whenever it is soiled, contaminated, and/or penetrated by blood or other potentially infectious materials.
6. Double gloving for any invasive surgical procedures.
7. Don special surgical gown/attire e.g. space suit in arthroplasty surgery, due to the potential of morbidity/mortality if SSI occurs.

6.2.8 Asepsis and surgical technique

1. Adhere to principles of asepsis when placing instruments or devices.
2. Assemble sterile equipment and solution immediately prior to use.



3. Use sharp surgical blade or scissors to avoid unnecessary soft tissue trauma.
4. Handle tissue gently, maintain effective haemostasis, minimise devitalised tissue and foreign bodies, and eradicate dead space at the surgical site.
5. Use delayed primary skin closure or leave an incision open to heal by secondary intention if the surgeon considers the surgical site to be heavily contaminated.
6. If drainage is necessary, use a closed suction drain. Place drain through a separate incision distant from the operative incision. Remove the drain as soon as possible.

6.2.9 Post-operative care measures

1. Protect with sterile dressing for 24 to 72 hours postoperatively if the incision has been closed primarily.
2. Separate post-operation clean surgical wound patients from infected patients; assign separate areas for them.
3. Maintain post-op glucose control.
4. Wash hand before and after changing dressing and following contact with the surgical site.
5. Do not unnecessarily open the wound or change dressing.
6. When an incision dressing must be changed, use sterile technique.
7. Educate patient and family members regarding proper incision care, symptoms of SSI, and the need to report such symptoms.
8. Discharge post-operative patients early, as soon as they are fit to be discharged.

6.2.10 Developed a good surveillance system to study the incident of SSI.

1. Use CDC definitions of SSI for identifying SSI among surgical inpatients and outpatients.
2. Use method that accommodates available resources and data needs for the surveillance.
3. Periodically calculate operation specific SSI rates stratified by variables shown to be associated with increased SSI risk (e.g., NNIS risk index).
4. Report appropriately stratified operation specific SSI rates to surgical team members. The frequency and format for such rate documentations will be determined by the surgical load, the objectives of the local and national continuous quality improvement initiatives.

6.3 Hospital Acquired Pneumonia (HAP)

Pneumonia is one of the three most common HCAs. The risk factors for nosocomial pneumonia are extremes of age, severe underlying disease, immunosuppression, depressed sensorium, cardiopulmonary disease, and post thoraco-abdominal surgery. Patients who are mechanically ventilated are at risk for ventilator-associated pneumonia.

Most bacterial nosocomial pneumonias occur by aspiration of bacteria colonising the oropharynx or upper gastrointestinal tract of the patient. Intubation and mechanical ventilation greatly increase the risk of nosocomial bacterial pneumonia because they alter first-line patient defenses.

Hospital-acquired pneumonia (HAP) or nosocomial pneumonia refers to any pneumonia contracted by a patient in a hospital at least 48–72 hours after being admitted. It is thus distinguished from community-acquired pneumonia. It is usually caused by a bacterial infection, rather than a virus.

Ventilator-associated pneumonia (VAP) is defined as nosocomial pneumonia in a patient on mechanical ventilatory support (by endotracheal tube or tracheostomy) for at least 48 hours.

Healthcare associated Pneumonia (HCAP) covers pneumonias acquired in non-hospitalized patients who had significant experience with the health care system. Such contact include:

1. residence in nursing home or other long term care facility,
2. have undergone IV therapy (including chemotherapy or wound care) within the previous 30 days,
3. have been hospitalized in an acute care hospitals within the previous 90 days, or
4. outpatient treatment in a hospital or haemodialysis centre within the previous 30 days).

This excludes HAP and VAP. Thus the term HAP is often used to represent both HCAP and VAP.

6.3.1 Prevention of Person-to-Person Transmission of Bacteria

1. Wear gloves when in contact with mucous membranes, handling respiratory



- secretions or objects contaminated with respiratory secretions. Hand hygiene should be performed after removal of gloves.
2. Change gloves and decontaminate hands between contacts with different patients.
 3. Change gloves between contacts with a contaminated body site and the respiratory tract or respiratory device on the same patient.
 4. Wear a mask and an apron or gown when soiling of respiratory secretions from a patient is anticipated (e.g. intubation, tracheal suctioning, tracheostomy, bronchoscopy) and change it after performing a procedure and before providing care to another patient.
 5. Use a sterile, single-use catheter, if the open-method suction system is employed. Use only sterile fluid to remove secretions from the suction catheter if the catheter is to be used for re-entry into the patient's lower respiratory tract.

6.3.2 Precautions for prevention of aspiration

1. Remove devices such as endotracheal, tracheostomy, oro/nasogastric tubes from patients as soon as they are not indicated.
2. Perform orotracheal rather than nasotracheal intubation unless contraindicated.
3. When feasible, use an endotracheal tube with subglottic suctioning to allow drainage of tracheal secretions that accumulate in the subglottic area.
4. Ensure that secretions are cleared from above the endotracheal tube cuff before deflating the cuff in preparation for tube removal or before moving the tube.
5. Elevate the head of the bed 30 – 45 degrees in a patient on mechanical ventilation or at high risk for aspiration (e.g. on oro or nasogastric tube)
6. Routinely verify appropriate placement of the feeding tube.
7. Routinely assess the patient's feeding tolerance by measuring residual gastric volume and adjust the rate and volume of enteral feeding to avoid regurgitation.

6.3.3 Prevention of Postoperative Pneumonia

The following patients are at high risk for developing postoperative pneumonia:

- i. Age >60 years
- ii. History of chronic lung disease or smoking
- iii. On steroids for chronic conditions

- iv. History of chronic alcohol consumption
 - v. Impaired sensorium
 - vi. History of cerebrovascular accident with residual neurologic deficit
 - vii. General anaesthesia
 - viii. Upper abdominal or thoracic surgery
 - ix. Emergency surgery
 - x. Obesity
1. Patients at risk should receive pre and postoperative instructions on deep breathing exercises and incentive spirometry.
 2. Encourage all postoperative patients to take deep breaths and ambulate them as soon as possible postoperatively, unless medically contraindicated.
 3. Provide adequate postoperative analgesia to facilitate effective coughing and deep breathing.

6.3.4 Prevention of VAP

The ventilator care bundle has four key components:

1. Elevation of the head of the bed to between 30 and 45 degree
 2. Daily sedation vacation
 3. Peptic ulcer prophylaxis.
 4. Deep venous thrombosis prophylaxis unless contraindicated
- (Refer to Ventilator Care Bundle Manual, Quality of Health Care Section, Medical Development Division, MOH; Nov. 2006)*

Note:

The implementation of ventilator care bundle, regular oral hygiene with chlorhexidine 2% and appropriate use of antibiotics are associated with a significant reduction in VAP rate.

The monitoring of Ventilator care bundles compliance and VAP rates are Key Performance Indicators for all ICUs in Ministry of Health Hospitals.

6.3.5 Sterilization or disinfection and maintenance of respiratory equipment and devices.

For sterilisation or disinfection of respiratory equipment *(Refer to Chapter 7: Infection Control in Specific Healthcare setting, General Intensive Care)*

1. Do not routinely sterilise or disinfect the internal machinery of mechanical ventilators.

2. Do not routinely change the ventilator breathing circuit on the basis of duration of use. Change the ventilator breathing circuit when visibly soiled.
3. Drain and discard periodically any condensate in the circuit. Take precautions not to allow the condensate to drain towards the patient.
4. Use sterile water to fill bubble-through humidifiers.
5. Do not routinely change more frequently than every 48 hours an HME that is in use on a patient. Change when it malfunctions mechanically or becomes visibly soiled.
6. Change the oxygen delivery system (tubing, nasal prongs or mask) that is in use on one patient when it malfunctions or becomes visibly contaminated or between uses on different patients.
7. Clean, disinfect, rinse with sterile water and dry nebulisers between treatments on the same patient. Replace nebulisers with those that have undergone sterilisation or high-level disinfection between uses on different patients.
8. Use only sterile fluid for nebulisation, and dispense the fluid into the nebuliser aseptically. Use aerosolised medications in single dose vial whenever possible.
9. Change the mouthpiece of a peak flow meter or the mouthpiece and filter of a spirometer between uses on different patients.
10. Change entire length of suction-collection tubing and canisters between uses on different patients.
11. Between uses on different patients, clean reusable components of the anaesthetic breathing system, inspiratory and expiratory breathing tubing, y-piece, reservoir bag, humidifier, and tubing, and then sterilise or subject them to high-level liquid chemical disinfection or pasteurization in accordance with the device manufacturers' instructions. A bacterial-viral filter placed between the y-piece and the mask or endotracheal tube serves to protect the patient and the anaesthesia delivery system from contamination.

6.4 Intravascular Catheter Related Infections

6.4.1 Surveillance

1. Monitor the catheter sites visually or by palpation through the intact dressing on a regular basis, depending on the clinical situation of individual patients. If patients have tenderness at the insertion site, fever without obvious source, or other manifestations suggesting local or BSI, the dressing should be removed to allow thorough examination of the site.

2. Encourage patients to report any changes in their catheter site or any new discomfort.
3. Record the date of catheter insertion and removal, and dressing changes. Do not routinely culture catheter tips.

6.4.2 Hand hygiene

1. Adhere to proper hand hygiene.
2. Palpation of the insertion site should not be performed after the application of antiseptic, unless aseptic technique is maintained.

6.4.3 Aseptic technique during catheter insertion and care

1. Maintain aseptic technique for the insertion and care of intravascular catheters.
2. Wearing clean gloves rather than sterile gloves is acceptable for the insertion of peripheral intravascular catheters if the access site is not touched after the application of skin antiseptics.
3. Sterile gloves should be worn for the insertion of arterial and central catheters.
4. Change the dressing on intravascular catheters using aseptic technique.

6.4.4 Catheter insertion

Do not routinely use arterial or venous cut down procedures as a method to insert catheters

6.4.5 Catheter site care

1. For cutaneous antisepsis - Disinfect clean skin with an appropriate antiseptic before catheter insertion and during dressing changes. Although an alcoholic-chlorhexidine 2% preparation is preferred, tincture of iodine, an iodophor, or 70% alcohol can be used.
2. Allow the antiseptic to remain on the insertion site and to air dry before catheter insertion.
3. Allow povidone iodine to remain on the skin for at least 2 minutes or longer if it is not yet dry before insertion.
4. Do not apply organic solvents (e.g. acetone and ether) to the skin before insertion of catheters or during dressing changes.

6.4.6 Catheter-site dressing regimens

1. Use either sterile gauze or sterile, transparent, semi permeable dressing to cover the catheter site.
2. Tunnelled CVC sites that are well healed might not require dressings.
3. If the patient is diaphoretic, or if the site is bleeding or oozing, gauze dressing is preferable to a transparent, semi-permeable dressing
4. Replace catheter-site dressing if the dressing becomes damp, loosened, or visibly soiled.
5. Change dressings at least weekly for adult and adolescent patients depending on the circumstances of the individual patient.
6. Do not use topical antibiotic ointment or creams on insertion sites (except when using dialysis catheters) because of their potential to promote fungal infections and antimicrobial resistance.
7. Do not submerge the catheter under water. Showering should be permitted if precautions can be taken to reduce the likelihood of introducing organisms into the catheter (e.g. if the catheter and connecting device are protected with an impermeable cover during the shower).

6.4.7 Selection and replacement of intravascular catheters

1. Select the catheter, insertion technique, and insertion site with the lowest risk for complications (infectious and non-infectious) for the anticipated type and duration of IV therapy.
2. In adults, use an upper- instead of a lower-extremity site for catheter insertion. Replace a catheter inserted in a lower-extremity site to an upper-extremity site as soon as possible. In paediatric patients, the hand, the dorsum of the foot, or the scalp can be used as the catheter insertion site.
3. Promptly remove any intravascular catheter that is no longer essential. Do not routinely replace central venous or arterial catheters solely for the purposes of reducing the incidence of infection.

6.4.8 Replacement of Peripheral and Midline Catheters

There is no need to replace peripheral catheters more frequently than every 72-96 hours to reduce risk of infection and phlebitis in adults except as clinically indicated.

6.4.9 Replacement of CVCs, Including PICCs and Hemodialysis Catheters

1. Do not routinely replace CVCs, PICCs, haemodialysis catheters, or pulmonary artery catheters to prevent catheter-related infections.
2. Do not remove CVCs or PICCs on the basis of fever alone. Use clinical judgment regarding the appropriateness of removing the catheter if infection is evidenced elsewhere or if a non-infectious cause of fever is suspected.
3. Do not use guide wire exchanges routinely for non-tunnelled catheters to prevent infection.
4. Do not use guide wire exchanges to replace a non-tunnelled catheter suspected of infection.
5. When adherence to aseptic technique cannot be ensured (i.e.: when catheters are inserted during a medical emergency), replace all catheters as soon as possible and after no longer than 48 hours.
6. Use clinical judgment to determine when to replace a catheter that could be a source of infection (e.g. do not routinely replace catheters in patients whose only indication of infection is fever). Do not routinely replace venous catheters in patients who are bacteremic or fungemic if the source of infection is unlikely to be the catheter.
7. Replace any short-term CVC if purulence is observed at the insertion site, which indicates infection.
8. Replace all CVCs if the patient is haemodynamically unstable and if Catheter Related Blood Stream Infection (CRBSI) is suspected.
9. Do not use guide wire techniques to replace catheters in patients suspected of having catheter-related infection.

6.4.10 Replacement of administration sets, needleless systems, and parenteral fluids

6.4.10.1. Administration sets

1. Replace administration sets, including secondary sets and add-on devices, no more frequently than at 72-hour intervals, unless catheter-related infection is suspected or documented.
2. Replace tubing used to administer blood, blood products, or lipid emulsions (those combined with amino acids and glucose in a 3-in-1 admixture or infused separately) within 24 hours of initiating the infusion.

6.4.10.2. Needleless intravascular devices

1. Change the needleless components at least as frequently as the administration set.
2. Change caps no more frequently than every 72 hours or according to manufacturers' recommendations.
3. Ensure that all components of the system are compatible to minimise leaks and breaks in the system.
4. Minimise contamination risk by wiping the access port with an appropriate antiseptic and accessing the port only with sterile devices.

6.4.10.3. Parenteral fluids

1. Complete the infusion of lipid-containing solutions (e.g. 3-in-1 solutions) within 24 hours of hanging the solution.
2. Complete the infusion of lipid emulsions alone within 12 hours of hanging the emulsion. If volume considerations require more time, the infusion should be completed within 24 hours.
3. Complete infusions of blood or other blood products within 4 hours of hanging the blood.

6.4.11 IV-injection ports

Clean injection ports with 70% alcohol or an iodophor before accessing the system. Cap all stopcocks when not in use.

6.4.12 Preparation and quality control of IV admixtures

1. Admix all routine parenteral fluids in the pharmacy in a laminar-flow hood using aseptic technique.
2. Do not use any container of parenteral fluid that has visible turbidity, leaks, cracks, or particulate matter or if the manufacturer's expiration date has passed.
3. Use single-dose vials for parenteral additives or medications when possible.
4. Do not combine the left over content of single-use vials for later use.
5. Multidose should be discouraged whenever possible.
6. If multidose vials are used;
 - Refrigerate multidose vials after they are opened if recommended by the manufacturer.

- Cleanse the access diaphragm of multidose vials with 70% alcohol before inserting a device into the vial.
- Use a sterile device to access a multidose vial and avoid touch contamination of the device before penetrating the access diaphragm.
- Discard a multidose vial if sterility is compromised.

6.4.13 In-line filters

Do not use filters routinely for infection-control purposes.

6.4.14 Prophylactic antimicrobials

Do not administer intranasal or systemic antimicrobial prophylaxis routinely before insertion or during use of an intravascular catheter to prevent catheter colonisation or BSI

6.4.15 Central Venous Catheters, Including PICCs, Hemodialysis, and Pulmonary Artery Catheters, in Adult and Pediatric Patients.

6.4.15.1 General principles

1. Use a CVC with the minimum number of ports or lumens essential for the management of the patient.
2. Use totally implantable access devices for patients who require long-term, intermittent vascular access. For patients requiring frequent or continuous access, a PICC or tunnelled CVC is preferable.
3. Use a fistula or graft instead of a CVC for permanent access for dialysis.
4. Do not use haemodialysis catheters for blood drawing or applications other than haemodialysis except during dialysis or under emergency circumstances.
5. Use antiseptic at the haemodialysis catheter exit site after catheter insertion and at the end of each dialysis session only if this antiseptic does not interact with the material of the haemodialysis catheter per manufacturer's recommendation.

6.4.15.2 Selection of catheter insertion site

1. Weigh the risk and benefits of placing a device at a recommended site to reduce infectious complications against the risk for mechanical



complications (e.g. pneumothorax, subclavian artery puncture, subclavian vein laceration, subclavian vein stenosis, haemothorax, thrombosis, air embolism, and catheter misplacement).

2. Use a subclavian site (rather than a jugular or a femoral site) in adult patients to minimise infection risk for non-tunnelled CVC placement.
3. Place catheters used for haemodialysis and pheresis in a jugular or femoral vein rather than a subclavian vein to avoid venous stenosis if catheter access is needed.

6.4.15.3 Maximal sterile barrier precautions during catheter insertion

1. Use aseptic technique including the use of a cap, mask, sterile gown, sterile gloves, and a large sterile sheet, for the insertion of CVCs (including PICCS) or guide wire exchange.
2. Use a sterile sleeve to protect pulmonary artery catheters during insertion.

6.4.15.4 Replacement of catheter

1. Do not routinely replace CVCs, PICCs, haemodialysis catheters, or pulmonary artery catheters to prevent catheter-related infections.
2. Do not remove CVCs or PICCs on the basis of fever alone. Use clinical judgment regarding the appropriateness of removing the catheter if infection is evidenced elsewhere or if a non-infectious cause of fever is suspected.
3. Guide wire exchange:
 - Do not use guide wire exchanges routinely for non-tunnelled catheters to prevent infection.
 - Use a guide wire exchange to replace a malfunctioning non-tunnelled catheter if no evidence of infection is present.
 - Use a new set of sterile gloves before handling the new catheter when guide wire exchanges are performed.

6.4.15.5 Catheter and catheter-site care

1. General measures
Designate one port exclusively for hyperalimentation if a multi-lumen catheter is used to administer parenteral nutrition.

2. Antibiotic lock solutions
Do not routinely use antibiotic lock solutions to prevent CRBSI. Use prophylactic antibiotic lock solution only in special circumstances (e.g. in treating a patient with a long-term cuffed or tunneled catheter or port with a history of multiple CRBSIs despite optimal maximal adherence to aseptic technique).
3. Catheter-site dressing regimens;
 - Replace the catheter-site dressing when it becomes damp, loosened, or soiled or when inspection of the site is necessary.
 - Replace dressings used on short-term CVC sites every 2 days for gauze dressings and at least every 7 days for transparent dressings, except in those paediatric patients in which the risk for dislodging the catheter outweighs the benefit of changing the dressing.
 - Replace dressings used on tunneled or implanted CVC sites no more than once per week, until the insertion site has healed.
4. Ensure that catheter-site care is compatible with the catheter material.
5. Use a sterile sleeve for all pulmonary artery catheters.

6.4.15.6 Additional Recommendations for Peripheral Arterial Catheters and Pressure Monitoring Devices for Adult and Pediatric Patients

1. Use disposable, transducer assemblies when possible in selection of pressure monitoring system.
2. Do not routinely replace peripheral arterial catheters and pressure monitoring system to prevent catheter-related infections.
3. General measures in care of pressure monitoring systems;
 - Keep all components of the pressure monitoring system (including calibration devices and flush solution) sterile.
 - Minimise the number of manipulations of and entries into the pressure monitoring system. Use a closed-flush system (i.e., continuous flush), rather than an open system (i.e., one that requires a syringe and stopcock), to maintain the patency of the pressure monitoring catheters.
 - Do not administer dextrose containing solutions or parenteral nutrition fluids through the pressure monitoring circuit.



4. Sterilisation or disinfection of pressure monitoring systems Use disposable transducers.
5. Recommendations for Umbilical Catheters Replacement of catheters;
 - Remove and do not replace umbilical artery catheters if any signs of CRBSI, vascular insufficiency, or thrombosis are present.
 - Remove and do not replace umbilical venous catheters if any signs of CRBSI or thrombosis are present.
 - Cleanse the umbilical insertion site with alcoholic chlorhexidine 2% before catheter insertion. Avoid tincture of iodine because of the potential effect on the neonatal thyroid.
 - Do not use topical antibiotic ointment or creams on umbilical catheter insertion sites because of the potential to promote fungal infections and antimicrobial resistance.
 - Add low doses of heparin (0.25-1.0 F/ml) to the fluid infused through umbilical arterial catheters.
 - Remove umbilical catheters as soon as possible when no longer needed or when any sign of vascular insufficiency to the lower extremities is observed. Optimally, umbilical artery catheters should not be left in place >5 days.
 - Umbilical venous catheters should be removed as soon as possible when no longer needed but can be used up to 14 days if managed aseptically.

6.5 Prevention of CVC-line related Infection.

The CVC care bundle consists of five evidence-based procedures as recommended by the CDC:

1. Hand hygiene
2. Maximal barrier precautions upon insertion
3. Chlorhexidine skin antisepsis
4. Optimal catheter site selection, with subclavian vein as the preferred site for non-tunnelled catheters.
5. Daily review of line necessity with prompt removal of unnecessary lines.

6.5.1 Hand hygiene

When caring for CVCs, hand hygiene should be performed:

- a. Before and after palpating catheter insertion sites.
- b. Before donning gloves and gown.
- c. Before and after inserting, replacing, accessing, or dressing a catheter
- d. After removing gloves

6.5.2 Maximal barrier precautions upon insertion

Maximal barrier precautions during CVC insertion are the same as for any other surgical procedure that carries a risk of infection.

- They consists of the use of a cap, mask, sterile gloves and long sleeved gowns by the operator or those assisting in the insertion.
- Maximal barrier precautions also includes covering the patient with a large sterile drape, with a small opening for the site of insertion.
- The assistant who helps to drop items into the field should wear cap and mask.

6.5.3 Chlorhexidine skin antisepsis

- It is recommended that the skin is to be disinfected with 2% chlorhexidine-based preparation before catheter insertion and during dressing changes.
- The proper method of sterilising an insertion site with chlorhexidine 2% involves scrubbing in a back and forth motion for 30 seconds as this method may be more effective in reducing the bacterial burden prior to the puncture of the skin and dressing.
- The antiseptic solution must be allowed to dry completely before puncturing the site.

6.5.4 Optimal catheter site selection, with subclavian vein as the preferred site for non-tunnelled catheters

6.5.5 Daily review of line necessity with prompt removal of unnecessary lines.

Daily review of central line necessity will prevent unnecessary delays in removing lines that are clearly not needed for the care of the patient. Many times, central lines remain in place simply because they provide reliable access and because medical personnel have not considered removing them.



Apart from the daily review of central line necessity, the healthcare worker should also look into the followings:

- The CVC dressing is intact and changed
- The CVC hub decontamination has been performed before each hub access
- Hand hygiene has been performed before and after all CVC maintenance/ access procedure.

Note: Chlorhexidine gluconate 2% in alcohol has been used for cleaning the insertion site during dressing change.

7

INFECTION CONTROL IN SPECIFIC HEALTHCARE SETTINGS

7.1. General Intensive Care Unit

Many infectious agents are present in the intensive care unit. Patients may develop infections during their stay in the unit while healthcare workers may be infected during the course of their duties. It is therefore important for all healthcare workers working in the intensive care units to observe infection control measures strictly to minimise nosocomial infections.

For Standard Precautions, Transmission-based (Additional) Precautions and Hand Hygiene, please refer to Chapter 3 on Isolation Precautions.

7.1.1 Healthcare Workers and Visitors

1. All healthcare workers shall remove their white clinical coats before entering the unit.
2. There is no necessity to change footwear or use shoe covers upon entering the unit.
3. All healthcare workers shall perform hand hygiene with alcohol-based hand rub upon entering and before leaving the unit.
4. Staff nurses shall change out of their uniforms and wear ICU attire/OT suits while working in the unit. It is advisable for those who wear headscarves to change to caps while on duty. Headscarves or ties if worn shall be neatly tucked into blouses/shirts.
5. Wearing of bangles or bracelets is not allowed during patient care. Ear studs (not dangling earrings) and flat band rings are allowed. Wristwatches and flat band rings must be removed when performing hand hygiene.
6. Sleeves shall be rolled up above the elbow when handling patients and equipment.

7. Healthcare workers with transmittable infections are advised not to work in the unit until treated.
8. Visitors shall be limited to not more than two per patient at any one time.
9. Visitors shall be instructed on hand hygiene practices before and after visiting.
10. Visitors shall not be discouraged from having contact with the patients e.g. touching. However, they shall be instructed to observe transmission-based precautions whenever applicable.

7.1.2 Personal Protective Equipment

1. Wearing of gloves does not replace hand hygiene. Perform hand hygiene both before wearing and after removing gloves.
2. Wear sterile gloves when performing procedures requiring a sterile field or involving sterile areas in the body e.g. arterial cannulation, central venous cannulation, tracheal suction, bronchoscopy, wound dressing, lumbar puncture, tracheostomy and urinary catheterisation.
3. Wear non-sterile gloves when touching blood, saliva, body fluids or secretions, excretions, contaminated items or surfaces, mucous membranes and non-intact skin.
4. Change gloves when performing separate procedures, from a contaminated to a clean body site on the same patient.
5. Wear surgical mask and protective eyewear or face shield to protect mucous membranes of the eyes, nose and mouth during procedures and patient-care activities that are likely to generate splashes or sprays of blood, body fluids, secretions e.g. tracheal intubation, tracheal suction and tracheostomy.
6. Wear gown (clean, non-sterile) or plastic apron during procedures and patient-care activities that are likely to generate splashes or sprays of blood, body fluids, secretions or excretions, e.g. chest physiotherapy, wound dressing, sponging, tracheal intubation, tracheal suction.
7. Remove gloves, soiled gown or apron promptly and perform hand hygiene after removal. Do not use the same gown, apron or gloves on different patients.
8. Refer to table below for common procedures and recommendations for personal protective equipment.

Procedure	Gloves		Gown		Goggle/ Eye shield	Apron
	Sterile	Non-sterile	Sterile	Non-sterile		
Arterial cannulation	✓				✓	✓
Bone marrow aspiration	✓		✓		✓	
Bronchoscopy	✓			✓	✓	
Blood sampling for culture	✓					✓
Central venous catheter, haemodialysis catheter insertion	✓		✓		✓	
Chest tube insertion	✓		✓		✓	
Lumbar puncture	✓		✓		✓	
Nasogastric tube insertion		✓				✓
Peripheral venous cannulation		✓			✓	✓
Pulmonary artery catheterisation	✓		✓		✓	
Peritoneal dialysis catheter insertion	✓				✓	
Urinary catheterisation	✓					✓
Tracheal intubation		✓			✓	✓
Tracheostomy	✓		✓		✓	
Tracheostomy tube change	✓				✓	✓
Tracheal suctioning	✓				✓	✓
Ventilator tube change	✓				✓	✓
Wound dressing	✓					✓
Physiotherapy		✓			✓	✓
Sponging		✓				✓

Note: Mask is to be worn for all above procedures



7.1.2.3 Ward Environment

1. The ward shall be kept tidy and neat at all times.
2. Flowers and plants are not allowed in patient-care areas.
3. Patients who are infected or colonised shall be nursed in isolation rooms if available or cohorted in a designated area or cubicle.
4. The cleaning schedule shall be followed, with adequate daily cleaning of all work areas. Cleaning tasks shall follow in the order from 'clean' to 'dirty'.
5. Floors shall be cleaned according to cleaning schedule (follow HSIP schedule) or as necessary. Brooms shall not be used in clinical areas. Use dust-retaining mops, which are specially treated or manufactured to attract and retain dust particles.
6. Clean and disinfect high touch areas (work areas, bedrails, drip stands, bedside nursing tables, keyboards, light switches, doorknobs) with medium-level disinfectant at least daily or when visibly dirty.
7. Sinks, hand basins and surrounding floor and wall areas shall be cleaned at least daily, or more frequently as required.
8. Hand basins shall ideally be equipped with non-touch taps with anti-splash devices. Antiseptic hand wash in non-refillable dispensers and disposable paper towels shall be readily available.
9. Clean wall, blinds or window in patient-care areas when visibly dusty or soiled and when patients are discharged.
10. Curtains in patient-care areas shall be changed weekly and when patients are discharged. Use plastic curtain that can be decontaminated regularly (e.g. daily) if feasible.
11. Protect mattresses and pillows with water impermeable material. Clean and disinfect between patients.
12. Standard precautions apply in spills management. Confine and contain the spill by using paper towels or disposable absorbent material to absorb the bulk of the blood or body substances. Spills shall be cleaned up before the area is disinfected. Avoid aerosolisation of spilled material.
13. Terminal disinfection must be done when a patient is discharged. The bed, all reusable items and equipment in the room/area are to be cleaned and then disinfected. The bed can be used for the next patient only when it is completely dry. If possible, open the windows to air the room. The room can be used for the next admission only when it is completely dry.

7.1.2.4 Medical Instruments and Equipment

1. All reusable medical items must be thoroughly decontaminated before disinfection or sterilisation. If not adequately decontaminated, disinfection or sterilisation is not effective.
2. All packaged and wrapped sterile items must be transported and stored while maintaining the integrity of packs to prevent contamination. If a sterile item is suspected of being unsterile (e.g. damaged packaging) the item must not be used.
3. Reusable equipment must not be used for another patient until it has been appropriately cleaned and/or disinfected.
4. Each patient shall have his/her own set of bedside equipment e.g. stethoscope, BP cuff, thermometer.
5. Surfaces of computers, keyboards and non-critical medical equipment e.g. physiologic monitors, ventilators, infusion pumps shall be cleaned at least daily with a low or intermediate level instrument grade disinfectant and allowed to air dry. Use washable keyboard covers if feasible. Alternatively cover keyboard with 'cling wrap' and change daily.

7.1.2.5 Respiratory Equipment

1. Use only sterile water/fluid for respiratory care e.g. suctioning, filling of humidifiers and nebulisers.
2. Use a closed system for filling of sterile water into heated water humidifier.
3. Do not routinely change the ventilator breathing circuit based on duration of use. Change the ventilator breathing circuit when visibly soiled.
4. Drain and discard periodically any condensate in the circuit. Take precautions not to allow the condensate to drain towards the patient.
5. Do not routinely change the heat-moisture exchanger more frequently than recommended by the manufacturer. Change when it malfunctions mechanically or becomes visibly soiled.
6. Change the oxygen delivery system (tubing, nasal prongs or mask) that is in use on one patient when it malfunctions or becomes visibly contaminated or between uses on different patients.
7. Clean, disinfect, rinse with sterile water and dry nebulisers between treatments on the same patient. Replace nebulisers with those that have undergone sterilisation or high-level disinfection between uses on different patients.

8. Use only sterile fluid for nebulisation and dispense the fluid into the nebuliser aseptically. Use aerosolised medications in single dose vials whenever possible.
9. Change the mouthpiece of a peak flow meter or the mouthpiece and filter of a spirometer between uses on different patients.
10. Change the entire length of suction-collection tubing and canisters between uses on different patients.
11. Closed-suction system for tracheal suctioning is recommended for infectious respiratory cases.

Isolation Rooms in ICU

General

An isolation facility aims to control the airflow in the room so that the number of airborne infectious particles is reduced to a level that ensures cross-infection of other people within a healthcare facility is highly unlikely. The rooms have high rates of air exchange relative to other patient areas. This applies to both ventilation air supply and exhaust flow rates.

Isolation rooms do not necessarily always require the provision of an Anteroom. This should be determined by the proposed operational policy and be included at an early stage of the design process. Where an Anteroom is however a requirement, it must be provided with self-closing doors and be of adequate area to allow for the donning or removal of personal protective equipment or clothing.

7.2. Neonatal Intensive Care Unit

7.2.1 Introduction

The prevention, control, and surveillance of infections within the Neonatal Services, includes the new-born in special care and neonatal intensive care nursery.

7.2.1.2 Personnel

7.2.1.2.1 Employee Health

- HCW must understand the risks of transmission of contagious diseases to new-borns and report acute infections to their immediate supervisor.
- HCW with acute airborne infections should not be working.

- HCW with exudative hand dermatitis, staphylococcal skin lesions, or herpetic hand lesions should not perform direct patient care.
- Varicella vaccinations for non-immune staff are strongly recommended. (Please refer to Chapter 11: Occupational Health & Safety).
- Needle stick/sharps injuries must be reported immediately in accordance with hospital policy

7.2.1.2.2 Education

- All HCW should be briefed and orientated on the Infection Control Policies specific to Neonatal Unit upon entry to the nursery.
- All HCW should attend regular in-services training on Infection Control practices i.e.. hand hygiene, sharps safety, personal protective equipment, and medical waste training etc.

7.2.1.2.3 Personal Protective Equipment

- The routine use of gowns upon entering NICU is not encouraged. Protective clothing should be worn by all HCW in contact with blood, body fluids, secretions, and excretions (with the exception of sweat), or during close contact with the patient, materials or equipment which may lead to contamination of clothing with micro-organisms.
- Personnel should wear a sterile scrub suit prior to performing aseptic procedures.
- Gloves:
 - Gloves must be worn for invasive procedures, contact with sterile sites, and non-intact skin, mucous membranes, and all activities that have been assessed as carrying a risk of exposure to blood, body fluids, secretions and excretions; and when handling sharp or contaminated instruments.
 - Gloves should be worn by personnel taking care of infants with respiratory viral infections and other infectious diseases to reduce the risk of transmission
 - Gloves should be worn as single use items.
 - Change gloves between caring for different patients, or between different care/treatment activities for the same patient.



- Mask and eye protection / face shield must be worn to protect the mucous membranes of the eyes, nose, and mouth during procedures that are likely to generate splashes or sprays of blood, body fluids, secretions, and excretions.
- A closed incubator may be used in maintaining barrier precautions, however since the exterior surfaces and entry ports are readily contaminated by micro-organisms, the exterior surface of the incubator should always be considered contaminated.

7.2.1.3 Procedures

1. Full aseptic techniques should be observed whenever invasive techniques are performed on the patient
2. Blood and body fluid specimens should not be placed on the writing table adjacent to the patient.
3. Care of IV lines:
 - Full aseptic technique for insertion of central venous lines. Chlorhexidine 2% with or without alcohol 70% may be used prior to insertion of arterial and central line.
 - For ELBW infants the chlorhexidine should be removed with sterile water or normal saline after the procedure to avoid dermatitis or chemical burn.
 - Dressings are changed whenever there is contamination with blood.
 - Keep three way taps ports always clear of blood contamination and the port must be spigotted if not in use.
 - IV-line tubing which is temporarily disconnected should be protected from contamination.
 - Always maintain the TPN lines in a closed system with no other infusions running through it. Inline filters should be used.
 - Injections of drugs should be given through an injection port or via a needleless connector.
 - IV cannulas are to be removed when no longer required or if there are signs of local inflammation.

7.2.1.4 Hand Hygiene

- Good hand hygiene is mandatory as per standard hand hygiene procedure.

- Rings, watches, bracelets, and artificial nails should not be worn during patient care. All jewellery should be removed before hand hygiene as it interferes with effective hand washing. Cuts and abrasions should be covered with waterproof dressings.
- All other HCW such as radiographers, physiotherapists and occupational therapists must observe strict hand hygiene before and after attending to these neonates.

7.2.1.5 Newborn Isolation

- Most infections in new-borns do not require special isolation precautions. General new-born care measures will prevent transmission of most infections between new-borns.
- For most infections, where airborne precaution is not necessary, an isolation area can be defined in the nursery or NICU.
- Infants suspected or diagnosed with infections transmitted by contact or droplets (i.e., rubella, mumps, pertussis, and RSV) may require special precautions. A distance of at least three feet should separate infected infants from other infants.
- Cohorting of infants may be necessary during nosocomial outbreaks. All patients with multi-resistant organism infections should be clearly identified and isolated.
- There are no special restrictions for admission of infants born outside the hospital. They should be treated the same as infants born in the hospital. Infants suspected or diagnosed with perinatal varicella, measles or TB would require airborne precautions and isolation.

7.2.1.6 Infected Mother

- Transmission from mother to new-born usually occurs during delivery. The advisability of maternal-infant contact will be discussed and decided on an individual basis.
- If a mother develops a fever or infection while the infant is rooming in, she will be evaluated on an individual basis by the Paediatric doctor as to the advisability of the infant remaining with the mother.
- Infant of active pulmonary tuberculosis mother should not be separated from mother and breast-feeding can be continued. Separation is not necessary as these infants would be commenced

on full anti - TB treatment for active TB or isoniazid prophylaxis for latent TB. Surgical mask however, should be provided for mother if she is still infectious.

- Postpartum separation of the mother and new-born is considered in the following conditions:
 - Uninfected new-born of mother with peripartum varicella should be separated until maternal lesions have dried.
 - Mother has extensive *Staph. Aureus* infection with drainage not contained by dressings.

7.2.1.7 New-born

7.2.1.7.1 Feeding

- Infant should be given breastmilk or colostrum from the biological mother. It should not be shared.
- Hand expression is preferred. If breast pump is used, the apparatus should be changed between patients, washed in soap and water and rinsed thoroughly with cooled boiled water
- Breast milk is collected and stored in a clean manner. Milk will be expressed into clean containers.
- Breast milk may be stored in the refrigerator for a maximum of 48 hours or frozen for three (3) months. (Please refer to Breast Feeding Guideline WHO/UNICEF 2009)
- Frozen breastmilk should be:
 - used within 24 hours
 - thawed in a refrigerator or no more than 15 minutes under warm water with precautions to prevent contamination.
 - after thawing, milk should be used promptly or stored in the refrigerator for no longer than 24 hours.
 - any prepared milk at room temperature that is unused after 2 hours should be discarded. (Please refer to Breast Feeding Guideline WHO/UNICEF 2009)
- Contraindications of breast feeding:
 - Maternal HIV infection
 - HSV lesions around the nipples
- Infant formula can be stored in the ward refrigerator at temperature of 40C for 24 hours. (Please refer to Breast Feeding Guideline WHO/ UNICEF 2009)

- Continuous infusion tube feeding should be set up with the same aseptic precautions used for intravenous fluids. Syringes of milk and tubing should be changed regularly.
- Orogastric tube for feeding should be replaced based on manufacturer recommendation and tube material, usually every 5 days.

7.2.1.7.2 Skin care

- Maternal blood and secretions will be removed with sterile cotton sponges and sterile water once the new-born's temperature has stabilised. Gloves will be worn for handling of all infants until this has been done.
- Localized cleaning of the diaper area and other soiled areas will be carried out as needed, using sterile water.
- Whole body bathing and antiseptic soaps are not necessary for routine care but may be indicated in outbreaks.

7.2.1.7.3 Cord care

- The cord will be cut and tied using aseptic technique.
- The umbilical cord stump is left to dry or may be cleaned with 70% alcohol daily.

7.2.1.7.4 Eye care

- At delivery, the new-born's eyes should be cleansed with sterile cotton to remove secretions and debris.
- Profuse purulent discharge within the first day of life should be informed immediately to the paediatric doctor to be treated as gonococcal conjunctivitis until proven otherwise

7.2.1.8 Infant Contact with Parents

- Only parents can visit the neonatal wards.
- Infants should only be handled by their own parents after proper hand hygiene.
- Parents are not allowed to visit during sterile procedures.
- Parents who are unwell with respiratory or diarrhoeal illness, should not be allowed to visit.

7.2.1.9 Patient Care Equipment.

- Disposable items are utilized as much as possible where available.
- All infant care units are cleaned and disinfected between each use. Equipment will be labelled, cleaned and stored ready for use.
- All infants are transferred to a clean bassinet, incubator or radiant warmer every seven days or whenever necessary.
- Ventilator breathing circuits and tubing must not be routinely changed. Change the circuit when it is visibly soiled.
- Air filters from incubators should be changed every three months.
- Fan, unit, and housing unit will be cleaned with a damp cloth with disinfectant on a weekly basis.
- Routine daily cleaning of incubator with sterile water is recommended. Use different piece of cloth for inner and outer incubator surfaces.
- Equipment assigned to a single patient such as resuscitation bags, masks, and other items in contact with the new-borns skin or mucous membranes should be replaced and sterilized or receive high-level disinfection on a regular basis.
- Sterile supplies and equipment are preferably stored according to policy (refer to Chapter 13).
- Examining equipment, such as stethoscopes and ophthalmoscopes should be reserved for use for each patient or disinfected with 70% alcohol in-between patients.

7.2.1.10 Housekeeping

- The nursery should be kept clean and dust free. The ward manager/ senior staff nurse is responsible for supervising the cleaning of their areas.
- Cleaning methods that minimise dust dispersal should be used. Cleaning and dusting of the accessory areas (windows, shelves, and counters) will be done daily with an approved hospital disinfectant. Phenolic solutions should not be used.
- Where a piece of equipment is used for more than one patient, e.g. weighing machine, it must be cleaned following each use.
- Floors and other horizontal surfaces are cleaned daily with an approved hospital disinfectant.
- All blood spills should be attended to immediately using spillage kit.
- No food or drinks are allowed in patient care area.

7.2.1.11 General Policies

- Soiled linen will be handled according to hospital policy. Clean linen and gowns will be stored in closed cabinets.
- Needles, syringes, and sharps are disposed of (uncapped and uncut) into puncture resistant sharp containers.
- Staff will report promptly, all occupational injuries or infectious exposures to the hospital Occupational Safety and Health committee for treatment and follow-up.

7.3 Operation Theatre

This policy deals principally with Infection Control Practices in operating theatre, MOH. The objective of the policy is to provide safer environment for both patients and HCWs in the operating theatre.

7.3.1 Maintaining a Safer Environment in the Surgical Procedure Area

1. Clean OT attire is a part of aseptic environmental control in OT. It ensures protective barrier for the patients undergoing surgery as well as for the personnel during the surgical procedures. The OT attire is to be worn within the OT only. One should not go outside the OT in the attire.
2. Specific rooms should be designated for performing surgical/clinical procedures and for processing instruments and other items.
3. It is important to control number of HCWs, traffic and activities in these areas since the number of people and the amount of activity influence the number of microorganisms that are present and therefore influence the risk of infection post surgery.

7.3.2 Location of the Operating Theatre Suites

1. Operating theatres may be located in either purpose-built units or in converted hospital accommodation.
2. Separated from the main flow of hospital traffic and from the main corridors; however, it should be easily accessible from surgical wards, emergency rooms and other supporting departments.
3. The floor should be covered with antistatic material, and the walls should be painted with impervious, antistatic paint (polyurethane paint, epoxy paint) to reduce dust levels and allows for frequent cleaning. The surfaces must with stand frequent cleaning and decontamination with disinfectant.



7.3.3 Layout of the Operating Theatre

1. The operating theatre should be zoned and access to these zones should be under the control of OT personnel.
2. Aseptic and clean areas should be separated from the outer areas.
3. Physical barriers are needed in order to restrict access and to maintain unidirectional movement of air in converted theatre units.
 - i. **Outer zone:** This zone should contain:
 - A main access door
 - An accessible area for the removal of waste
 - A sluice
 - Storage for medical and surgical supplies
 - An entrance to the changing facilities.
 - ii. **Clean or semi-restricted zone:** This zone contains:
 - The sterile supplies store
 - An anaesthetic room
 - A recovery area
 - A scrub-up area
 - A clean corridor
 - Rest rooms for the staff.

Staff must change into theatre clothes, protective hair cover and shoes before entering this area, but there is no need for a mask, gloves, or a gown. There should be unidirectional access from the above area to the aseptic area i.e.. the operating theatre, preferably via the scrub-up area. The OT should be restricted to HCWs involved in the actual operation.

- iii. **Aseptic or restricted zone:** This zone should be restricted to the working team. It includes:
 - The operating theatre.
 - The sterile preparation room (preparation of sterile surgical instruments and equipment

Staff working in this area should change into theatre clothes, should wear masks and gowns, and, where necessary, should wear sterile gloves.

7.3.4 Doors

1. The doors to the OT should be kept closed except for the necessary passage of the patient, personnel, supplies and equipment.
2. Disrupted pressurization mixes the clean air of the OT with the corridor air, which has a higher microbial count. Cabinet doors should remain closed..

7.3.5 Temperature and Humidity

(Please refer to 12: Environmental)

7.3.6. Standard Ventilation for Conventional (non-laminar airflow) Operating Theatres

1. Airborne contaminants may enter OT via the following routes:
 - Through the supply air
 - Shed by operating staff
 - Through surgical activities
 - Transferred from adjacent spaces
2. The air flow and microbiological air quality should be assessed on commissioning, after major renovation/repair, change of HEPA filter or outbreak of an infectious disease in the theatre or elsewhere within the theatre suite.
3. For non-emergency repairs, the Infection Control Team must be notified by the manager in charge of the theatre, at least a week in advance, so that microbiological air sampling, particle air sampling and tests for positive pressure ventilation can be performed if deemed necessary by the team.
4. The minimum standard for microbiological air counts for conventional operating rooms is less than 10 CFU (colony-forming unit)/m³ when the theatre is empty.
5. The particle count in OT should follow the ISO 5 Standard. (refer Appendix)
6. Airflow from ceiling to floor and directed under positive pressure (15% of access air); higher in operating room than in the corridor.
7. The air within the operating room should be at a positive pressure compared with other theatre suites and with the external corridors, and should be at a range of 20 -25 ACH (air changes per hour).
8. Planned preventive maintenance shall be performed following the agreement between MOH and the maintenance concession companies
9. Changing of HEPA filter shall follow the manufacturer requirement or as stipulated in the maintenance agreement, whichever is earlier.
10. Frequency of temperature, ACH and humidity monitoring shall be according to the documented agreement between each hospital and the concession company.

7.3.7 Ultra clean ventilated (UCV) OT

- UCV OT is used in high risk operation such as
- Cardiac surgery
- Vascular surgery
- Implant/bone surgery
- Neurosurgery
- Transplant surgery

Below are recommended standard parameters:

Standard Parameters	UCV OT
1. OT temperature	18-22 °C in general
	15-17 °C (cardiac OT)
2. Air sampling count	Colony count ≤ 1 CFU/m ³
3. Air humidity	50 - 60%
4. Air change rates	> 25 air changes / hour
5. Particle count	3520 particles / m ³ (> = 0.5 μ micron)

7.3.7.1 Ultra clean air or laminar air flow systems.

1. Laminar airflow is designed to move free air particle over the aseptic operating field in one direction. It can be designed to flow vertically or horizontally and is usually combined with high efficiency particulate air (HEPA) filters. HEPA filters remove particles > 0.3 micron in diameter with an efficiency of 99.97%.
2. Ultraclean air can reduce the incidence of infection especially for high risk operations. The air from ultra clean air or laminar flow systems used for high-risk surgery must be tested microbiologically annually or following major modification. Preferably, room should be equipped with laminar air flow system with a unidirectional ventilation system in which filtered, bacterial free air is circulated over the patient and return to receiving air inlet (HEPA filter).

When do we perform particle counts?

- Once a year in conventional OT and every 6 months in ultraclean OT
- HEPA filters are replaced
- Increased in reported OT infections
- If any alterations or construction were done within the OT

Procedure to be followed if OT fails a Particle Count test:

- Inform hospital administrator and engineering unit
- Close the affected OT
- Shut down the AHU and change HEPA filter
- Restart AHU and do terminal cleaning of OT
- Suggest to re-test after 24 hours
- OT should not be utilised until all the measurements are within the standards recommendation
- Any failure in getting the particle count shall be consulted with the Engineering Unit, maintenance company and the contractor (new project).

7.3.8 Type of Air supplied to the operating theatre

1. Plenum/Unidirectional Ventilation

This is the most frequently used system in general purpose operating theatre

2. Laminar Flow Ventilation (Ultra Clean Ventilation)

This system is unidirectional and delivers air flow over the operating table of 25-30 ACH.



Samples of Laminar airflow

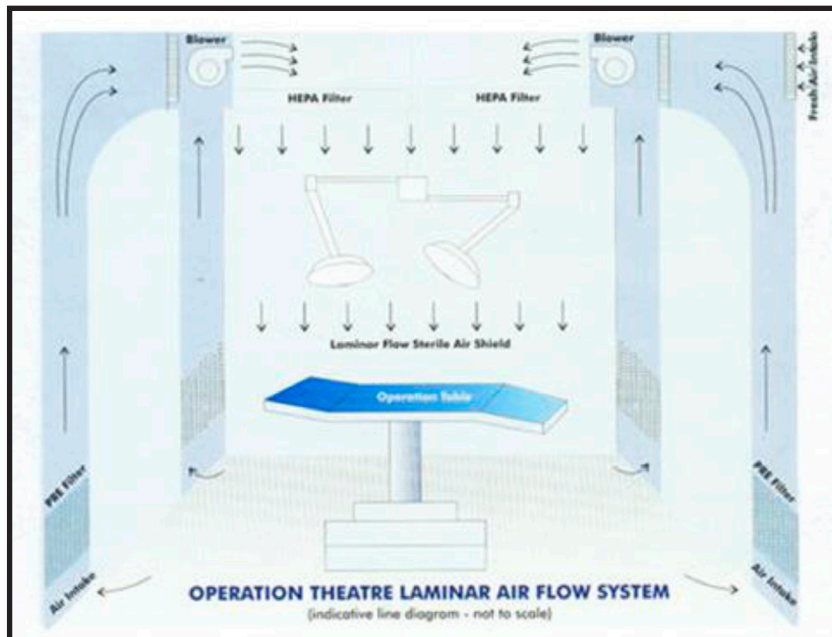
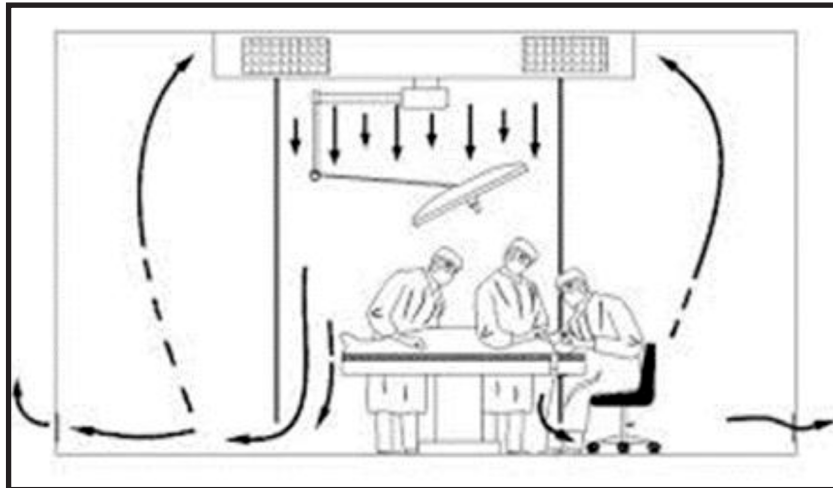

7.3.9 Protective Clothing for Use in the Operating Theatre

The use of barriers minimizes a patient's exposure to microorganisms that might be shed from the skin, mucous membranes, or hair of surgical team members as well as protects surgical team members from exposure to blood and to blood-borne pathogens.

1. Theatre attire should include such as items as sterile gloves, caps, masks, gowns or waterproof aprons, and protective eyewear.
2. All personnel entering the operation theatre should have good personal hygiene e.g. bath and shampoo. All personnel should change to new scrub suite which is 'lintfree' before entering the theatre.
3. The operation theatre should have specific written policy and procedure for proper attire to be worn. The attire should be changed if wet or grossly soiled.
4. Head cover is worn to protect gross contamination from hair during procedures.
5. Change footwear before entering operation theatre area. Footwear should be comfortable, supportive, able to minimise fatigue and provide personnel safety.
6. A single disposable 3-ply surgical mask to be worn in restricted area which is 95% efficient in filtering microbes from droplet particles in exhalation and also filter inhalation. Fluid resistant mask is an advantage. Change mask when necessary when wet or after it has been removed for other purposes.

7.3.10 Surgical Hand Scrubbing

(Please refer to Chapter 3 on hand hygiene section)

1. A thorough hand wash for 5 minutes for first operation using antiseptic lotion with brush on finger nails and followed by rubbing method to all the rest of the fingers and hands including 2 inch above elbow. Rinse thoroughly with clean water.
2. Dry hands and arms using sterile towel. The top half of the sterile towel is held in one hand while the opposite hand and forearm is dried.
3. A rotating motion beginning at the hand and working toward the elbow is used for drying. When the first hand and forearm are dry, the towel half of the towel that is unused is grasped with the dry hand, and the opposite hand and forearm is then dried. Care is taken not to return to an area that is already dried.
4. For subsequent cases, a 2 minutes recommended hand rub with alcohol based solution is sufficient and dry hand as stated above.

7.3.11 Gowning

1. The sterile gown is put on after drying the hands and arms with a sterile towel. Sterile gowns may be reusable or disposable.
2. The gown should be constructed of a material that provides a barrier to prevent the passage of microorganisms from the surgical team to the patient and vice versa. Gowns should be as lint free as possible, free from tears or holes, fluid resistant or fluid proof.
3. Reusable gowns eventually lose their barrier qualities with repeated laundering. Quality monitoring should be in place to ensure that only gowns of appropriate quality are used.

7.3.12 Gloving

1. Gloves are donned after gowning. The sterile gloves are put on in two ways: using closed method technique and open method technique.
2. The closed gloving method is preferred for establishing the initial sterile field.
3. The open gloving method is used when changing a glove during a surgical procedure or when donning gloves for procedures not requiring gowns.
4. Sterile gloves donned should be rinsed or wiped with sterile water or sterile saline prior to the surgical incision in order to remove the glove powders.

7.3.13 Draping

1. Drapes serve as a barrier to prevent the passage of micro-organism between sterile and non-sterile areas. Sterile drapes are used to create a sterile surface around the incision site. Draping is also used for sterile supplies and equipment. This area is referred to as a sterile field.
2. The sterile field includes the patient, furniture and other equipment that is covered with sterile drape. The sterile field is isolated from unsterile surfaces and items.
3. Draping should always be done from a sterile area to an unsterile area. Drape the area nearest to the scrub person first. Once the drape is applied, it should not be adjusted.
4. Sterile drapes are positioned over the patient in such a way that only minimal area of skin around the incision site is exposed.
5. Drapes maybe reusable or disposable. Criteria of drape must be water resistant, lint-free, flame resistant and able to provide an effective barrier to prevent passage of microorganisms from non-sterile to sterile areas.

7.3.14 Establishing a Sterile Field

1. All items used in the sterile field must be sterile.
2. A sterilisation indicator (tape) must be applied to each sterile package / item used. Where penetration is of concern, a chemical indicator should be inserted into each packet.
3. All tables and flat surfaces must be dry and dust-free prior to the placement of sterile bundles and /or supplies.
4. The instrument table is draped with a repellent drape prior to the placement of instruments and supplies. The instrument table is considered sterile only at top level.
5. All draped tables should be moved by the circulating nurse whose hands should be placed below the drape, on the table leg..
6. Ring stands if used, must be draped with a water repellent drape. When the scrub nurse moves the ring stand, she does so by placing her hands inside the basin.
7. The gown is considered sterile from axilla level to the table level in front only and from the elbow to the stockinette cuff. The gown should have a barrier front and sleeves. Wrap around gowns should be turned by a sterile person. If a sterile instrument is used by a non-sterile person to turn the gown, the instrument should be discarded after use.

7.3.15 Dispensing of the Sterile Supplies

1. Supplies should be opened as close as possible to the time that the surgical procedure is to commence.
2. Each package is checked for the expiry date and wrapper integrity prior to opening.
3. The edges of envelope wrapped packages are opened away from circulating nurse with corners secured before presenting it to the scrub nurse.
4. Peel back packages should be carefully opened to ensure proper adhesive separation and prevent tearing of the package.
5. The scrub nurse should take each item directly from the package held by the circulating nurse. Careful placement of items on the sterile field is acceptable if the hand of the circulating nurse is covered by the wrap and does not extend over the sterile field.
6. Sterile supplies are handled as little as possible and once positioned should not be moved and/or shifted.
7. Once supplies are opened they should not be left unattended. Sterile set-ups should not be covered for future use.

8. Non-sterile persons should not reach over the sterile field. Sterile persons should not reach over non-sterile areas.
9. Fabric or paper wrapped sterile items which are dropped on the floor should be considered non-sterile and should not be used.
10. Once the patient has entered the theatre where sterile supplies have been opened, those supplies may only be used on that particular patient. These supplies should be discarded in the event of cancellation.
11. Large bundles of packages should be opened on a flat surface and not while holding it in the hand.
12. Opened sterile bottles should be used for only one patient. The entire contents of bottle should be dispensed or the remainder discarded.
13. Care should be taken when pouring solutions to avoid splashing. The scrub nurse should hold the edge of the table so that circulating nurse need not reach over the sterile field to pour. The solution should be poured in a slow steady stream.

7.3.16 Maintaining the Sterile Field

1. Precautions should be taken to prevent moisture contamination and subsequent strike-through by using water resistant materials.
2. The scrub team should remain close to and face the sterile field. Movement is only from sterile to sterile areas. When changing positions the scrub personnel will pass front to front or back to back. They should avoid changing levels, they either sit or stand. Talking should be kept to a minimum. Scrub personnel should not lean on sterile areas.
3. The unscrubbed team should remain at least one foot from the sterile field. Movement is from non-sterile to non-sterile areas. They should not pass between sterile areas.
4. Breaks in aseptic technique should be monitored, documented and corrective action taken as soon as possible.
5. A sterile field is maintained by:
 - Placing only sterile items within the sterile field.
 - Opening, dispensing, or transferring sterile items without contaminating them.
 - Considering items located below the level of the draped client to be non-sterile.
 - Not allowing sterile personnel to reach across non-sterile areas or vice versa or to touch non-sterile items.
 - Recognizing and maintaining the service provider's sterile area.

- When gowned this area extends from chest to the level of the sterile field; sleeves are sterile from 5 cm above the elbow to the cuff. The neckline, shoulders, and back are considered to be non-sterile areas of the gown.
- Recognizing that the edges of a package containing a sterile item are considered non-sterile;
- Recognizing that a sterile barrier that has been penetrated (wet, cut or torn) is considered contaminated;
- Being conscious of where your body is at all times and moving within or around the sterile field in a way that maintains sterility;
- Not placing sterile items near open windows or doors.

7.3.17 Management of infectious cases that requires additional precaution. (e.g. TB and MDRO)

1. Pre-operative Management

- Appropriate personal protective equipment should be worn when performing hazardous procedures.
- All infectious cases should be listed last, unless in an emergency situation. Terminal cleansing will have to be done after this. Patient to be sent straight from ward to the operation room.
- All personnel involved should be informed regarding the infectious case.
- Proper specific disposable and protective attire to be used by all personnel.
- Personnel involved should be kept to the minimum.
- Only specifically required equipment should be kept in the operation room.
- Additional protective face shield should be worn when receiving patient in OT to protect from splashes especially when patients carry organisms that are transmissible via droplets (SARS, Ebola, H5N1)

2. Intra operative

- Induction of patient to be done on operation table in the theatre. Disposable items should be use wherever possible.
- Gentle handling during draping is required to minimise aerosol contamination of the environment.
- Additional protective face shield should be worn during the procedure to protect from splashes.

- Any operating attire to be changed as soon as possible when soiled during the procedure.
 - All the clinical waste should be thrown into the clinical waste bin and sharps to be disposed into the sharps bin by the person handling the sharps.
3. **Post-operative**
- Surgical instruments should be sent to CSSD as soon as possible.
 - Whenever it is not possible to do so (after office hours – spray with disinfectant (e.g..Endozyme) before sending to CSSD coming morning).
 - For bio-hazard cases, instruments are wrapped in 'biohazard plastic bag' and then sent to CSSD.
 - All laboratory specimens must be in clean secure containers and placed into the biohazard specimen plastic bag before being send to pathology.
 - Any contamination to the outside of containers should be cleaned with sodium hypochlorite 1:100. Ensure the containers are tightly sealed to avoid spillage.
 - Any linen used in the operating room will be placed in alginate red linen bag to be treated and laundered in hot water.
 - The room and all equipment should be decontaminated with sodium hypochlorite solution 1:100 and left to dry. The room can be reused once it's dry.

7.3.18 Waste and Linen

1. Waste should always be disposed of with minimal handling because there is a risk of blood-borne pathogen transmission.
2. Body fluids should be disposed of in the sluice by staff with appropriate PPE.
3. Used linen should be contained in hampers or in soiled laundry bags at the point of use. Linen that is saturated with body fluids should be placed in fluid proof bags.
4. Other contaminated waste should be handled and disposed of according to the facility's medical waste process.

7.3.19 Cleaning of the Operation theatre

(Please refer to Chapter 12 – Environment)

There should be a simple, clear, cleaning policy that can be adhered to easily. The cleaning equipment for the operating room must be dedicated and kept separate from the outer zone.

1. **Initial cleaning (at the beginning of the day)**
 - Clean floors and all horizontal surfaces operating/ procedure tables, examination couches, chairs, trolley tops or Mayo stands, lamps, counters, and office furniture with a cloth dampened with water to remove dust and lint that may have accumulated over night.
2. **Concurrent cleaning (between cases)**
 - Clean operating/procedure tables, examination couches, trolley tops or Mayo stands, lamps, counters, and any other potentially contaminated surfaces in operating theatres and procedure rooms with a cloth dampened with a disinfectant solution.
 - Immediately clean spills of blood or other body fluids with a chlorine solution. Clean visibly soiled areas of the floor, walls, or ceiling with a mop or cloth dampened with a disinfectant solution.
 - Discard waste when plastic bags of waste containers that are 2/3 full. Discard safety (sharps disposal) boxes, when they are 2/3 full.
 - Do not perform special cleaning or closing of the operating theatres after contaminated or dirty operations. (Please refer to Chapter 6 on Surgical site infection)
 - Thorough, routine cleaning is sufficient to provide a safe environment for subsequent cases given the high frequency of air changes in the well-designed OT.
3. **Terminal cleaning (end of the day)**
 - Clean all surfaces – including counters, tables, sink, lights, door handles with detergent, water and low level disinfectant then dry.
 - Pay particular attention to operating/procedure tables, making sure to clean the sides, base, and legs thoroughly.
 - Clean sluice with warm water and detergent. Wipe over non-metallic surfaces and equipment.
 - Clean the floors with a mop soaked in a disinfectant solution. Check sharps bins and remove and replace them if they are 2/3 full.
 - Clean non-clinical equipment and containers.

7.4 Dental Practice

7.4.1. Introduction

In dental practice, there is a significant risk of cross infection between patients and oral healthcare workers (OHCW) if adequate precautions are not taken. These guidelines set out standard infection control measures that OHCW should take to protect their patients, other OHCW and themselves.

7.4.2. Personal Protective Equipment (PPE)

PPE such as gloves, masks, protective eyewear, face shields and protective clothing should be worn by all OHCW in appropriate situations (Refer to Chapter 3).

Note: (specific for dental settings).

Debris, sprays and splashes generated during procedures may contain pathogens, which can enter the bloodstream of the OHCW (both the operator and assistant) through the nasal and oral mucosa and the conjunctiva.

1. **Gloves**

- Gloves must be worn when examining and treating patients or in any other situation where their hands may come in contact with blood, body fluids and clinical debris.
- Wearing gloves should never replace hand washing. Hands must be washed both before wearing and after removing gloves.
- Gloves must be discarded in the event of a visible puncture, and hands must be washed before new gloves are put on.
- Disposable gloves are single use items and must be discarded after each patient.
- If any item not directly involved in patient care needs to be touched, over-gloves (non-powdered gloves) may be worn or the treatment gloves removed. The over-gloves are then discarded or new gloves are put on upon returning to patient care.
- Double gloving should be practised during the treatment of high risk patients and during dental procedures.
- Gloves in boxes must not be exposed to aerosol contamination and therefore must be kept in a closed space.
- OHCW with non-intact skin (wounds, skin lesions etc.) on their hands must cover all breaks of the skin with waterproof dressings before wearing gloves (especially when performing a procedure).

Double gloves should be used if the hands are extensively affected.

- OHCW should however avoid invasive procedures or procedures involving the use of sharp instruments when their skin lesions are active, or if there are extensive breaks of the skin.
- Medical grade utility gloves that are puncture and chemical resistant must be worn when cleaning contaminated instruments and clinical contact surfaces. Used utility gloves must be considered contaminated and handled appropriately until properly disinfected. Utility gloves must be discarded if their barrier properties become compromised.

2. Mask

- Surgical masks which cover both the mouth and nose should be worn during all dental procedures, by both the operator and the assistant.
- Masks should be changed:
 - after a patient, if sprays or splashes have been generated during the procedure; or
 - when it becomes wet
- Single and 2-ply masks should not be used by either the operator or the assistant as they provide almost no protection. Fluid-resistant mask should be used and should not be touched while being worn.

3. Protective Eyewear and Face Shields

- OHCW and clinical support staff must wear protective eyewear to protect the mucous membranes of the eyes during procedures where there is the potential for penetrating injury or exposure to aerosols, splattering or spraying with blood, saliva or body substances.
- A face shield may be used as an alternative to protective eyewear.
- However, this does not protect from inhaled microorganisms and must be worn in conjunction with a surgical mask.
- Patients must be provided with protective eyewear to minimise the risk of possible injury from materials or chemicals used during treatment
- Protective eyewear and face shields must be cleaned with soap and water and disinfected with a low-level disinfectant after each patient.

7.4.3 Cleaning, Disinfection And Sterilisation Of Patient Care Items

Instrument Classification

Instruments are classified into 3 categories according to the degree of contamination and the type of post-treatment processing required.

- a. **Critical instruments** are surgical and other instruments that penetrate soft tissue or bone or enter or contact the bloodstream (e.g. forceps, scalpels, bone rongeur, scalers and burs). These instruments must be steam sterilised.
- b. **Semi-critical instruments** are instruments that do not penetrate soft tissue or bone but contact oral tissue or non-intact skin (e.g. amalgam condensers, mouth mirrors, dental handpieces and digital radiography sensors). These instruments should be steam sterilised. If steam sterilisation is not possible they should be treated with a high-level disinfectant.
- c. **Non-critical instruments** and devices are instruments and devices that come into contact only with intact skin (e.g. x-ray cone, position indicator device for x-ray cone, and face bow). They should be processed as follows:
 - not visibly contaminated– clean and disinfect with a low-level disinfectant; or
 - visibly contaminated with blood – clean and disinfect with an intermediate level disinfectant.

7.4.4 Sterilisation

- a. **Autoclaves**
 - All critical and semi-critical autoclavable instruments must be autoclaved.
 - If the need is to process packaged items or hollow or porous items, a vacuum autoclave (Type S or Type B) is required.
 - If the need is to process only solid, unpackaged instruments, a simple downward displacement (Type N) autoclave is sufficient.
- b. **Heat Sensitive Instruments**

Instruments that are sensitive to heat, such as intra-oral cameras, electronic periodontal probes, occlusal analysers and lasers should be cleaned and disinfected with at least a high-level disinfectant.

7.4.5 Surgical Procedures And Aseptic Technique

- The requirements for oral surgical procedures (minor oral surgery, dental implant placement etc.) include:
 - Sterile gloves
 - Appropriate sterile drapes
 - Sterile instrument
 - Surgical hand washing (using antimicrobial hand washing solution)
- Long hair must be tied back and covered and beards must be also covered
- The principles of sterile aseptic technique must be applied to all surgical procedures undertaken in the dental practice setting.
- Sterile gloves must be worn for all oral surgical procedures (including dental implant placement, cyst enucleation, removal of unerupted teeth and endodontic surgery)

7.4.6. Environmental Infection Control

a. Environmental Surfaces

- Environmental controls should be considered when designing or refurbishing dental clinics to reduce the risk of transmission of infectious agents.
- Environmental surfaces are divided into:
 - Clinical contact surfaces
 - Housekeeping surfaces

b. Clinical Contact Surfaces

- Clinical contact surfaces are surfaces that might become contaminated with blood during a procedure and include the dental chair, light handles, dental chair controls, dental radiographic equipment, chair side computers etc;
- For disinfection of these surfaces Refer to Disinfection Manual.
- OHCW must wear medical grade utility gloves and other PPE during the cleaning process

7.4.7 Other Treatment Room Equipment

a. Waterlines and water quality

Dental units should have a separate water reservoir system to supply water or an in-built filtration system to the handpieces and scalers.



Water from the domestic water supply should be filtered before entering the rinsing cup and spittoon.

Sterile irrigants such as sterile water as a coolant are required for surgical procedures such as dentoalveolar surgery, endodontic surgery, and dental implant placement.

Handpieces and scalers should have anti-retraction valves to prevent retrograde contamination of the lines by fluids from the oral cavity.

Waterlines must be flushed for a minimum of two minutes each morning and with handpieces attached for 20 to 30 seconds between each patient.

b. Dental Handpieces and other Detachable Devices Attached to Air and Waterlines

These include high and low-speed handpieces, scaling tips, air abrasion devices, and air and water syringe tips. Surface disinfection or immersions in disinfectants are not acceptable methods for processing these devices. These devices should be autoclaved.

For handpieces, cleaning and lubrication are the most critical factors in determining performance and durability. Manufacturers' instructions for cleaning, lubrication and sterilisation should be followed closely.

Hand piece re-processing:

- Flush handpieces while still attached to air/water lines in hose with bur inserted.
- Clean and dry hand piece.
- Flush with hand piece cleaner and lubricant. It is advisable to use an automated hand piece cleaning and lubricating system for this purpose.
- Pack and autoclave. Non-autoclavable handpieces should not be used. Flush air/water lines in hose before re-attaching a hand piece.
- Open package (lubricate, if necessary with separate post-sterilisation lubricant).
- Attach to hose and expel excess lubricant (with bur inserted).

c. Components Permanently Attached to Dental Unit Waterlines

These are likely to become contaminated with blood and body fluids during procedures. Examples include the handles and tubing of saliva ejectors, high volume evacuators, handpieces, scalers and air/water syringes.

These can be covered with protective barriers that should be changed after each procedure. If not covered during use, they must be cleaned and disinfected with a low-level disinfectant if not visibly contaminated. If visibly contaminated with blood, they must be disinfected with an intermediate level disinfectant before use on the next patient.

d. Other Non-autoclavable Equipment

Non-autoclavable equipment in the treatment room that might come in contact with the patient's blood and body fluids includes shade guides, the handles and tips of light curing units and pulp testers.

These must be cleaned and disinfected with a low-level disinfectant if not visibly contaminated. If visibly contaminated with blood, they must be disinfected with an intermediate level disinfectant before use on the next patient.

An alternative is to, whenever possible, cover such equipment with a protective barrier that is changed between patients.

e. Suction Units (Aspirators), Spittoons and Secretion Filters

Suction lines attached to the dental chair should be irrigated with disinfectant between patients and intermittently during long procedures. This prevents blood and saliva accumulating and coagulating in the lines.

Collection containers in portable suction apparatus must be cleaned and disinfected between patients.

Secretion filters/amalgam traps must be cleaned daily.

At the end of each day

- i. suck a non-foaming detergent through the high and low volume aspirators
- ii. flush a non-foaming detergent through the spittoon

7.4.8 Infection Control During Oral Imaging/Radiographic Procedures

Intraoral Imaging for Unidentified or Non-Specified Cases (Standard Precautions)

- a. Protective, non-powdered gloves should be worn for all imaging procedures and changed after every patient.



- b. Other PPE should be used to prevent spread of infection by saliva or blood.
- c. Use a clean sterile image receptor-holder for each patient. Digital receptors must also be placed inside appropriate dental barrier envelopes.
- d. Position the holder in the patient's mouth. Never insert fingers into the patient's mouth to position the holder.
- e. After the imaging procedure, remove the digital receptor from the barrier envelope and discard the envelope as clinical waste.
- f. Subsequently wash and clean the holder. If you have used a film packet (without a barrier envelope), then it should be washed with the holder under running water.
- g. Remove the film packet with forceps. Dip the film packet in disinfectant solution and dry the packet with a paper towel before sending for processing.
- h. If not autoclavable, the holder should be disinfected before use on the next patient.

Intraoral Imaging for Identified High-Risk Patients

- a. Apply a plastic cover (cling film) to the yoke, tube-head cone, control panel, headrest and any hand-held switches.
- b. The operator should double glove and PPE (disposable items where available) should be used.
- c. The intra-oral receptor (film packet or sensor) should be inserted into a dental barrier envelope to guard against contamination.
- d. The enveloped receptor is inserted into a disposable or autoclavable receptor-holder.
- e. A disposable apron should be placed over the lead apron worn by the patient.
- f. It is advisable to use a disposable receptor holder.
- g. Open the dental barrier envelope and allow the receptor to drop onto a paper towel/cup.
- h. The contaminated dental barrier envelope and the outer pair of gloves should then be disposed off as clinical waste.
- i. The receptor can now be sent for processing.
- j. All plastic covers (cling film) should be removed and the dental chair, x-ray tube, lead apron, exposure switch, door handle and other work surfaces should be disinfected using wipe surface disinfectant and left to dry for 10-15 minutes.
- k. The inner pair of gloves should be disposed off as clinical waste.

When using daylight-loading automatic processors ensure that there is no salivary contamination of the soft flexible arm sleeves. Film packets must only be introduced into the processor using clean hands or non-powdered gloves (powdered gloves may cause artefacts on the films).

Digital sensors, including photostimulable phosphor (PSP) plates (in addition to placing in dental barrier envelopes) should be disinfected between patients using the method recommended by the manufacturer.

7.4.9. Handling Of Laboratory Materials And Equipment For Repair

1. Dental Laboratory Materials

- Impressions, prostheses and appliances should be rinsed thoroughly to remove all visible blood and debris, and then disinfected before being sent to the laboratory.
- Gloves and other PPE should be worn during handling and transportation of impression, prosthesis and appliances.
- Items from the laboratory should be cleaned and disinfected with a high level disinfectant, prior to being sent to the surgery.
- Materials that are to be used in surgical procedures should be heat sterilised or if this is not possible, the item must be chemically sterilised.
- Containers should be used for transportation of items into and out of the laboratory
- Laboratory items that become contaminated (e.g. burs, polishing points, rag wheels, articulators, case pans and lathes) should be cleaned and sterilised or disinfected according to the manufacturers' instructions.

2. Equipment for Repair

All clinical and laboratory instruments should be cleaned prior to being sent for repair.

7.5. Scope Room

Guidelines detailing ways to minimise the risk of transmission of infection within the unit must be available. Standard Precautions, the minimum infection prevention practices applicable to all patient care regardless of the suspected or confirmed infection status of the patient, are the foundation of a sound infection prevention strategy. These include:

- Hand hygiene
- Personal protective equipment



- Safe medication administration practices
- Safe handling of potentially contaminated equipment or surfaces in the patient environment.

(Please refer to Chapter 13: Sterilization and Disinfection)

Recommendations for Hand Hygiene

- Hand hygiene should be performed
(Please refer to Chapter 3 Fundamental principles of Infection Prevention)
- The use of soap and water is required when hands are visibly soiled and after caring for patients with known or suspected infection causing diarrhoea such as *C. difficile*. Otherwise, the use of alcohol-based hand agents is adequate.

Recommendations for Personal Protective Equipment

(Please refer Chapter 3: Fundamental principles of Infection Prevention and Chapter 13: Sterilization and Disinfection)

Recommendations for Safe Medication Administration Practices

Safe medication administration practices promote safety in medication administration and have become a highly-scrutinized activity within healthcare in part because of evidence of pathogen transmission resulting from the improper use or reuse of syringes, multiple-dose drug vials, and IV equipment.

- Units should appropriately label all medications, including those used for sedation unless the medication is for immediate use (defined as drawn up and administered immediately without leaving the provider's hand).
- Units should limit the use of medications marked either on the container or noted in the package insert as "single patient use" to a single patient only and discard any remaining drug.
- Units should prepare and administer injections using aseptic technique. Single-dose vials, ampules, bags, or bottles of IV solution should only be used for a single patient.
- Units should not use the same syringe to administer medications to multiple patients regardless of whether the needle is changed, or an intervening length of IV tubing is used.
- Units should dispose of used syringes and needles at the point of use in a sharps container.
- Units should develop a clearly-defined policy for the management of sharps and sharps-related injuries, including the reporting of blood and body fluid exposures. This should be compliant to the national, state and local guidelines.

Recommendations for Safe Handling of Potentially Contaminated Equipment or Surfaces

Environmental cleaning of surfaces is mandatory with an appropriate disinfectant, emphasizing surfaces that are most likely to become contaminated with pathogens, such as those close to the patient (e.g. side rails) and other frequently-touched surfaces in the unit. Prompt and appropriate cleaning and decontamination of spills of blood or other potentially infectious material is mandatory.

Follow the manufacturer's directions for surface disinfection of patient care items. *(Please refer to Chapter 13: Sterilisation and Disinfection)*

- Appropriate contact time of disinfectant to achieve germicidal kill should be followed.
- Alcohol should not be used to clean environmental surfaces.

Properly clean and disinfect surfaces that are frequently touched by personnel or dirty equipment in the endoscopic procedure area at the beginning of the day, between cases, and during terminal cleaning. Frequently touched surfaces may include endoscopy keyboards, video monitors and consoles.

Terminal Cleaning

Please refer to Chapter 12: Environmental- terminal cleaning

Reusable Medical Equipment

The reprocessing protocol of reusable medical equipment such as endoscopes and endoscopic accessories must be strictly followed.

(Please refer to Chapter 13: Sterilisation and Disinfection)

7.6. Mortuary.

7.6.1 Introduction

The mortuary is a source of potential hazards and risks, not only to the autopsy team, but also to mortuary visitors and those handling the body in the mortuary. Mortuary personnel have professional responsibilities to be aware of and to minimize these hazards and risks. Safety and infection control policy in the mortuary is an issue not only relevant to the mortuary personnel, but also to the hospital administrators who are directly responsible for ensuring a safe working environment in the hospital.



Infections from dead bodies in the mortuary may be acquired by one or more of the following routes:

1. Inhalation
2. Inoculation
3. Ingestion
4. Entry through the conjunctiva or pre-existing wounds.

Since the presence of dangerous infections in dead bodies is not easily identifiable or even unknown prior to an autopsy, the prime objective in ensuring safety in the mortuary must be in the establishment of a series of barriers intended to protect against all possible infectious hazards. Barriers need to be established as follows:

1. Primary barriers: around perceived hazards.
2. Secondary barriers: around the mortuary personnel.
3. Tertiary barriers: around the autopsy room and mortuary.

For infection control, the mortuary should be operationally compartmentalised into the following physical areas or zones:

Clean areas (Green zones)	Reception and office spaces, pantries, consultation and viewing rooms.
Transitional areas (Yellow zones)	Vehicle bay, body storage areas, specimen rooms and changing rooms.
Dirty areas (Red zones)	Autopsy rooms

For safety and infection control in the mortuary, the following Hazard Group definitions should be applied:

Group 1	Unlikely to cause human disease.
Group 2	Can cause human disease and may be a hazard to mortuary personnel; it is unlikely to spread to the community and there is usually effective prophylaxis or treatment available.

Group 3	Can cause severe human disease and may be a serious hazard to mortuary personnel; it may spread to the community, but there is usually effective prophylaxis or treatment available. Example: Mycobacteria, <i>Bukholderia pseudomallei</i> , Hepatitis B & C viruses, HIV. These are to be considered as high-risk biohazard cases for mortuary management.
Group 4	Causes severe human disease and is a serious hazard to mortuary personnel; it is likely to spread to the community and there is usually no effective prophylaxis or treatment available. Example: Viral haemorrhagic fevers such as Ebola, Marburg and Hantavirus. These are to be considered as high-risk biohazard cases for mortuary management.

It is strongly desirable for autopsies of suspected or confirmed Hazard Group 3 cases (**high-risk biohazard cases**) not to be undertaken in mortuaries that do not meet the minimum mortuary building standards. These cases should not be performed in mortuaries without proper ventilation and suitable PPE equipment, and lacking operational compartmentalization for work safety. Autopsies of suspected or confirmed Hepatitis B & C, HIV and tuberculosis cases should be done at fully equipped mortuaries of tertiary hospitals and should not be performed in unsafe mortuaries of district hospitals that also lack experienced and trained autopsy personnel.

Autopsies of cases associated with Hazard Group 3 syndromic outbreak such as SARS should only be performed at a BSL-3 mortuary. These cases shall be categorised as high-risk syndromic biohazard cases. Current BSL-3 mortuaries in Malaysia are located at:

1. Department of Forensic Medicine, Hospital Sultanah Bahiyah, Alor Setar, Kedah.
2. Department of Forensic Medicine, Hospital Queen Elizabeth, Kota Kinabalu, Sabah.

It is strongly emphasised that autopsies of suspected or confirmed Hazard Group 4 infections should not be undertaken in mortuaries without BSL-4 facilities. Currently there is NO BSL-4 mortuary in Malaysia.



Safety and infection control in a mortuary must consider all procedures related to body handling, transfer and storage, autopsy procedures, autopsy specimen handling, clinical waste management and preparation of dead bodies for release.

7.6.2 Transfer of bodies from wards and A&E to the mortuary.

1. The ward staffs shall have the responsibility of notifying the mortuary of any suspected, probable or confirmed **high-risk biohazard cases**.
2. The ward staffs must attach biohazard tags to the bodies of all suspected or confirmed high-risk biohazard cases.
3. Any open wounds on the dead bodies must be properly covered by the ward staffs during completing the last office.
4. Medical personnel involve in the transferring of dead bodies shall not smoke, eat or drink while handling the bodies and they should avoid touching their mouth, eyes or nose.
5. Minimum PPE requirement should be observed by the medical personnel.
6. Contact with any spillage from the body bag should be avoided until proper decontamination can be done in the mortuary.
7. For suspected, probable or confirmed high-risk syndromic biohazard cases and Hazard Group 4 cases, the following additional requirements shall apply:
 - a. Preparation of body in the ward:
 - i. First layer – wrap body with white linen
 - ii. Second layer – place wrapped body in a body bag
 - iii. Third layer – place the body bag in a second body bag.
 - b. PPE for medical personnel involve in transferring the body shall comprise of double gloves, long-sleeved plastic apron and N95 mask.
 - c. Trolleys that have been used to transport these bodies shall be disinfected using appropriate disinfectant.

7.6.3 BID cases received directly from the police at the mortuary.

Sealed body bags that are received from the police should not be opened in the mortuary until further instructions from the Medical officers or Forensic Pathologists. The precautions mentioned in 7.6.2 apply.

7.6.4 Transfer of bodies between mortuaries.

Bodies of suspected, probable or confirmed **high-risk syndromic biohazard** cases should be transferred to more suitable mortuaries for autopsy.

1. Body preparation as mentioned in 7.6.2 applies.
2. The body in the body bag shall be transported in a dedicated hospital vehicle and any accompanying next of kin shall travel in a separate vehicle.
3. The hospital transporting vehicle shall be disinfected after use.

7.6.5 Body storage

1. It is desirable for all biohazard cases to be stored in the dedicated body refrigerators as soon as they are received at the mortuary. Exceptions can be made if no autopsy is required and the body can be released to the claimant within the stipulated time as per SOP upon receipt of the body at the mortuary.
2. All stored suspected or confirmed biohazard cases must have the biohazard tags attached to the refrigerator doors.

7.6.6 Autopsy procedure

Prior to the autopsy, the forensic pathologist or the prosecutor, based on the circumstances of death, shall undertake a pre-autopsy risk assessment to decide whether a case needs to be approached as a high-risk autopsy requiring additional safety precautions and suitable mortuary facilities. The forensic pathologist shall decide on the need to transfer the body to a more suitable mortuary for high-risk autopsies.

1. Compliance with proper PPE, suitable autopsy equipment, practising safe dissection techniques and good common sense are the foundations for a safe autopsy.
2. Although rapid pre-autopsy screening for blood-borne viruses (Hepatitis B, C and HIV) is useful for pre-autopsy risk assessment, non-reactive results should not lead to a downgrading of PPE or safety precautions if the circumstances of death suggest otherwise.
3. Minimum PPE for **non-high-risk biohazard** cases:
 - a. Surgical scrub suits.
 - b. Plastic apron.
 - c. Surgical mask and cap.
 - d. Waterproof boots.
 - e. Double gloves.
 - f. Cut-resistant glove on non-dominant hand.
4. PPE for **high-risk non-syndromic biohazard** cases such as Hepatitis C, HIV and tuberculosis:
 - a. Surgical scrub suits.
 - b. Plastic apron.

- c. N95 mask and cap.
 - d. Eye-visor/goggles.
 - e. Waterproof boots.
 - f. Double gloves.
 - g. Cut-resistant glove on non-dominant hand.
5. The autopsy of **high-risk syndromic outbreak** cases such as SARS, should only be performed at BSL-3 mortuaries in accordance with the established BSL-3 Work Procedure Manual of the relevant centres.
 6. Every effort must be made during autopsy to minimize liquid dispersion, splashing and production of aerosol.
 7. All members of an autopsy team must be trained and familiar with the proper handling of autopsy instruments to avoid sharp injuries.
 8. Hypodermic needles should never be handled by hands during autopsy. Only forceps should be used when attaching or removing needles from syringes.
 9. The use of PM40 pointed blades should be avoided during autopsy; only PM40 blunt tipped blade should be used.
 10. Open the chest wall by cutting along costal cartilage to avoid sharp ends. If ribs are cut instead of costal cartilage, it is strongly recommended that an oscillating saw with bone dust extractor be used instead of rib shear.
 11. It is strongly recommended that an oscillating saw with vacuum attachment be used for opening of the skull.
 12. Upon the conclusion of the autopsy, all prosectors must ensure that all used PPEs are disposed off accordingly and hand hygiene procedures are strictly complied with.

7.6.7 Specimen handling

1. All biological specimens acquired during an autopsy are biohazard materials and should be treated accordingly.
2. Group 3 agents such as mycobacterium, Hepatitis C and HIV are inactivated in formalin-fixed tissue specimens that have been acquired for histology.
3. Autopsy tissues/body fluid specimens that are intended for other pathological and toxicological analyses shall be collected in the prescribed containers and shall be handled as biohazard material.

7.6.8 Preparation for body release.

1. The release of bodies to the claimant should only be undertaken in the body preparation room and not directly from body storage area.
2. Should the body require ritual bathing or washing prior to leaving the

mortuary, the participants must be clearly counselled by the mortuary personnel or the Assistant Environmental Health Officer of any risks of infections and the preventive measures should be undertaken such as donning proper PPEs during the rite if necessary.

3. Body release of any **HIV suspected, probable or confirmed high-risk syndromic biohazard** and **Hazard Group 4** cases shall be carried out under strict precautionary measures and shall be supervised by an Assistant Environmental Health Officer.
4. For **suspected, probable or confirmed high-risk syndromic biohazard** and **Hazard Group 4** cases;
 - a. Bathing and *kafan* of a Muslim body maybe done in the autopsy/body preparation room by the trained personnel with strict adherence to PPE requirements. After *kafan*, the body shall be placed in a single body bag.
 - b. Embalming should be avoided.
 - c. The body shall be placed in body bag (s) and shall be coffined (sealed coffin) under the supervision of an Assistant Environmental Health Officer.
 - d. The next of kin is prohibited from opening the coffin.
 - e. It is advocated that the body is buried together with the coffin or cremated.

7.6.9 Clinical waste.

1. Waste for incineration
 - a. Disposable items such as paper shrouds, swabs, dressings, protective clothing and gloves.
 - b. Human tissues and body fluids.
 - c. Discarded syringes, needles and other disposable 'sharps', which must be placed in a 'sharps' bin immediately after use.
 - d. Xylene, formalin and alcohol.
2. Disposal into the drain
 - a. Non-contaminated fluids which must be flushed with plentiful of running tap water.
3. Chemical waste to be collected for disposal by appointed concession company

7.6.10 Visitors.

1. Next of kin should not be allowed to enter the dirty areas (red zones) of the mortuary.



2. Mortuary visitors who observe the autopsy shall comply with all PPE requirements that are appropriate for the case.

7.6.11 Exposure to Sharps Injuries.

Any mortuary personnel or visitors who accidentally injure themselves in the autopsy room, either through percutaneous or mucocutaneous exposure, to a suspected or confirmed HIV, Hepatitis B or C case shall be managed according to the relevant hospital procedures or policies for sharps injuries.

Confirmation of the infectious status of the dead body through microbiological testing shall be done in accordance to the relevant hospital procedures or policies for sharps injuries. It is strongly recommended that such investigation to include blood test for HIV via PCR method.

7.7 Burns

7.7.1 Introduction

Patients with burn injuries are highly susceptible to infection as a result of altered physical defence mechanism by the injury. Infection acquired by burn patients is a frequent cause of morbidity and mortality.

Sources of organisms are found in the patient's own endogenous (normal) flora, from exogenous sources in the environment and from health care personnel. The primary mode of transmission is direct or indirect contact-either through health care workers caring for the patient or from contact with inappropriately decontaminated equipment.

Prevention of infection in patients with burn injury is similar to other patient population. These include strict aseptic technique during dressing changes or other invasive procedures and using isolation room in treating patient with major burn or those infected with multiple drug resistant organism. The benefits of hydrotherapy as an adjuvant therapy to the standard treatment of burns are also universally recognized. Strategies for prevention of infection and control are described in these guidelines.

7.7.2 Burn Unit Environmental Control

- Standard precautions should be followed when caring for all patients with burn injury.
- Routine cleaning, disposal of waste and gathering of soiled linen is essential to keep the unit as clean as possible.

- Minimize contamination in the environment preferably by using laminar flow units and proper maintenance of the split unit air conditioning system. Positive pressure needs to be maintained inside the room to minimize infiltration of possible infectious particle.
- Relative humidity needs to be kept in the range of 30-60%, with higher humidity preferred to minimize the fluid loss of the patient.
- The environmental temperature around the patient was to be kept between 21- 29°Celsius ± 1°Celsius.
- Routine environmental surveillance culturing of burn unit is not generally recommended.

i. Common cubicles

- Common cubicles are used for patient with minor burn (Less than 20% TBSA burn).
- Patient treated in the common cubicles should have a spatial separation to ensure physical separation at least 2.5 – 3 m from other patients.
- Individual sink is preferable for hand hygiene or individual hand scrub should be provided to prevent cross contamination among patients.

ii. Isolation room

- Patient with major burn more than 20% TBSA or patient infected with multiple drug resistant organisms should be treated in the isolation room
- The concept of barrier techniques should be followed to reduce the environmental contamination present around the patient
(Please refer to Chapter 3: Fundamental Principles of Infection Prevention)

iii. Treatment room

a) Common treatment room

- Common treatment room should be used with caution as this will risk contaminating the surrounding environment and dressing materials stored within the vicinity.
- Change of dressing is best done by the patient's bedside.

b) Hydrotherapy room

- Hydrotherapy means both immersion in a tub* and showers in running warm water, provided these procedures contribute to the healing process.
- Hydrotherapy and its related equipment should be disinfected with high-level disinfection in between patients.
- Removal of dressing is best done in the hydrotherapy room.



* This aquatic environment is difficult to decontaminate because of continuous re-inoculation of organisms colonizing the patients' wound and because of the organisms' ability to form a protective glycocalyx in water pipes, drains and other areas, making them resistant to the actions of disinfectants.

iv. Plants and flowers

Plants and flowers should not be allowed in the Burn Unit as they harbour gram negative organisms such *Pseudomonas* species and fungi. These organisms may colonize the burn wound and many are intrinsically resistant to multiple antibiotics.

v. Toys and personal belongings

Paediatric patient with burns should be restricted to non-porous and washable toys only. This should be designated to individual patient use only, and thoroughly disinfect after use or before giving to another patient. Burn patient personal belongings from home are also not allowed (for example security pillow, blanket and soft toys).

7.7.3 Patient care items and equipment

All equipment and surfaces (such as beds, side rails, tables, wheelchairs, doorknobs and trolleys) should be adequately decontaminated (Please refer to MOH Disinfection Manual 2018).

i. Non-invasive items

- Non-critical items such as blood pressure cuffs, oxygen mask, nasal prongs, tubing, stethoscopes, bedpans, wheelchair, infusion pumps if used on areas without dry, occlusive dressings, may need high-level disinfection.
- These items should be restricted to an individual patient treated in the isolation room.

ii. Invasive items

- This refers to the care of endo-tracheal/ tracheostomy tube, intravascular catheter and continuous bladder catheterization.
- Intravascular catheter should be placed through normal intact skin, preferably at a sufficient distance from the burn wound to prevent contamination at the insertion site. If insertion of catheters is placed within or near the burn wound, appropriate dressing is required to cover the site of insertion.
- Prevention of UTI includes removal of the catheter as soon as it is no longer required for monitoring of urine output, maintaining a closed urinary drainage system, and performance of urinary catheter care

7.7.4 Health Care Worker (HCW) in Burn Unit

- Remove white coat before entering the unit
- Change to burn unit attire (if available).
- Strict hand hygiene before and after attending each patient.
- Use disposable glove, surgical mask and disposable gown or apron during handling of each patient.
- Strict aseptic technique when performing procedure or change of dressing.
- Follow contact precaution technique when entering the isolation room.
- Remove burn unit attire before leaving the unit.

7.7.5 Caregiver in Burn Unit

- Parent / guardian accompanying their child should be supervised when handling patient.
- They should follow the contact precaution technique if their child is nursed in the isolation room.

7.7.6 Visitors

- Only one visitor per patient is allowed at one time.
- Wear disposable gown or apron before entering the unit.
- Strict hand hygiene should be supervised by the ward staff.
- Physical contact should be limited especially for patient treated in the isolation room.

7.7.7 Care of the burn wound

- Bathe patient in the hydrotherapy room daily, twice daily or as needed. (***Exceptions are given to very ill patient; patient post wound debridement and skin grafting, or those on burn dressings that don't require daily changes*).
- Dressings should be removed in the hydrotherapy room or bedside** and disposed immediately.
- Patient should be covered with a sterile dressing towel before returning to their bed.
- Patient colonized with Multi Drug Resistant Organism (MDRO) should be cleaned last if common hydrotherapy / shower room / treatment room is used.
- All burn wounds should be covered with a sterile dressing towel until the next dressing is done.



- Wound dressing should be done under strict aseptic technique.
- Dressing should be kept clean and dry to prevent contamination to the surrounding area.
- Wounds that are left exposed such as face, ears, genitalia should be covered with topical ointment, or burn dressing.

7.7.8 Culturing and Surveillance

- Swab culture may be taken from the suspected MDRO burn wound on admission from patient who is being transferred from other unit or hospital for the purpose of isolation.
- Tissue culture or tissue biopsy should be taken when clinical infection is suspected.
- Routine wound swab for the purpose of screening on admission is not encouraged.
- Routine environmental surveillance culturing is not generally recommended in Burn Units.

7.7.9 Antibiotic Policy

- Burn wound flora and antibiotic susceptibility patterns change during the course of the patient's hospitalization
- Systemic antibiotic administration in burn patients should therefore only be used selectively, according to the specific susceptibility patterns of organism or documented infections and for a short period of time unless wound debridement is in several stages.
- Prophylactic systemic antibiotic therapy may be given immediately before, during and for one or two doses after the operative procedure, particularly in burn patients with extensive injury.
- Topical therapy may be applied to prevent infection and to treat ongoing infections or used as an adjunct to surgical treatment and systemic antibiotics. However, topical antibiotic prophylaxis applied to burn wounds, has no beneficial effects.

7.7.10 Early nutrition

Early enteral feeding reduces the incidence of wound colonization and infection by bowel flora. Early enteral feeding is likely effective because it increases circulation to the bowel, thereby decreasing ischemia post-injury and the translocation of bowel flora.

7.8. Haematology and Oncology Unit

7.8.1 Introduction

Haemato-oncology patients are immunocompromised due to both the underlying malignancy and chemotherapy. Patients with cancer are at increased risk of infections due to frequent contact with healthcare settings, exposure to other patients with transmissible infections. The placement of indwelling intravascular devices and invasive surgical procedures further increase their risk for infectious complications.

7.8.2 Common pathogens and sites of infection

1. The common pathogens include bacterial commensals from the gastrointestinal tract or skin and fungi including *Candida*, *Aspergillus* and other species.
2. Opportunistic infections include *Toxoplasma*, *Cryptococcus*, *Pneumocystis* and *Cryptosporidium* as well as infection or reactivation of viruses.
3. The common portals of infection include the oro-pharynx, periodontium, perianal, colon, skin, lung and esophagus.

7.8.3 Patient hygiene

1. Good oral hygiene is important, patients should be advised to brush their teeth at least twice a day with a soft-bristled toothbrush. Patients should be advised to rinse orally 4-6X/day with sterile water, normal saline or sodium bicarbonate. Removable dentures and space retainers should not be worn unless while eating and should be cleaned at least twice daily with soft brush and soaked in proper soaking solution.
2. Patients are advised to take daily bath with a mild soap with attention to good perineal hygiene.
3. Avoid the use of rectal thermometers, enemas, suppositories or rectal examinations especially during episodes of neutropenia,
4. Dental clearance should be performed 10-14days before induction of bone marrow transplant.
5. Skin sites, especially portal sites should be inspected daily. Care of central venous access should follow national guideline.

7.8.4 High risk neutropaenic diet

1. A low microbial diet is recommended to reduce the number of pathogens in food.
2. Attention should be paid to food preparation. Raw meats should be handled on separate surface and in accordance to chapter 7.13.

3. Food handlers should wash their hands before and after handling food. All fresh produce must be washed thoroughly in running water before being served.
4. Consumption of raw or undercooked meats or eggs or foods that may contain these e.g. mayonnaise, hollandaise sauce are not allowed All meat must be cooked to $>85^{\circ}\text{C}$. Leftovers should be discarded if left uneaten >2 hours.
5. Avoid fresh salads, fresh fruits, raw peanuts and seeds and raw or undercooked seafood. Cold food must be kept $<4^{\circ}\text{C}$.
6. Avoid naturopathic foods that may contain moulds. Pepper is to be avoided.
7. Sterile foods, on the other hand are expensive, tasteless and not proven in benefit.
8. Low microbial diet should continue at least 3 months after chemotherapy or autologous stem cell transplant. In allogenic stem cell transplant, it should continue until all immune-suppressives are stopped.
9. Water should be boiled. Tap water must be brought to a boil of >1 minute . Water filter capable of removing >1 micron or reverse osmosis is effective. Avoid ice made from tap water, fountain, bar. Avoid cold beverages made from tap water. National bottled or can drinks, commercially packaged noncarbonated drinks and fruit juice are allowed.

7.8.5 Facilities

1. Isolation in single rooms is beneficial in the setting of aplastic anaemia, induction therapy of high risk AML patients especially elderly and in haemopoietic stem cell transplant setting. Priorities are given to patients with highest risk of invasive mould infection (eg prolonged neutropenia, receiving GVHD treatment). All haemato-oncology patients should be placed in single rooms where possible. Where not available, they can be nursed in open cubicles with isolation facilities made available when necessary e.g. during MRSA or ESBL infections.
2. For isolation rooms, central or point-of-use HEPA filter with 99.97% efficiency for removing particles ≥ 0.3 μm in diameter (A111) with > 12 air exchanges per hour will remove bacteria and fungal spores. This is most effective to prevent hospital acquired *Aspergillus*. The use of laminar air flow rooms is controversial. When isolated room are not available, a portable industrial-grade HEPA filters are useful to prevent fungal infection and should be placed centrally in the open cubicle room(BIII).
3. Isolation rooms should have self-closing doors and well-sealed windows. Avoid false ceilings. Flooring and wall finishing can be scrub, non-porous,

non-carpeted and easily disinfected. A constant positive pressure of >2.5 Pa between the patient's room and hall way should be maintained to house immunosuppressed patients. Back-up emergency power should be available for all HCT (haematopoietic cell transplant) rooms.

4. Wards and rooms should be regularly cleaned at least once a day. Avoid vacuuming. Any water leaks should be attended to within 72 hours.
5. Avoid construction or renovation areas during transportation of patients to other facilities e.g. X-ray. Patients should wear an N95 mask if this is unavoidable.
6. When construction is undertaken, plans should include intensified mold-control measures with compliance to infection control measures. An Infection Control Risk Assessment should be planned prior to construction on a facility or design of a new facility (AIII).
7. Patients with concomitant active infectious diseases e.g. tuberculosis or active viral disease should be nursed in isolation room with negative pressure with an adjacent anteroom. If patient is visiting day care/clinic, advisable to come at a time when the facility is less crowded and instructed to don a surgical mask.
8. Equipment should be cleaned regularly, disinfected and maintained as directed by national guidelines.
9. Plants or dried flowers (DIII) and soft toys (BIII) are prohibited. Only hard plastic toys which can be washed, games and hand phone which can be disinfected are allowed.(BIII)

7.8.6 Personnel precautions

1. Health care workers should practice standard precautions and should be privileged to perform haematology /oncology procedures. Personnel should wear surgical masks when entering rooms if patients are severely neutropenic. Good hand hygiene practice with alcohol based hand rubs before entering and after leaving rooms. If hands are soiled with blood or body fluids, or caring for patients with infectious diarrhoea (eg Clostridium difficile) hand washing with soap and water should be done. Gloves should be worn upon entering room and discarded before exiting.
2. Health-care workers should practise hand hygiene before and after any direct contact with patients and prior to performing an aseptic task (accessing a port, preparing an injection).
3. Personnel should also comply to the immunization policy of the hospital. Generally health-care workers should be up to date to the current immunizations and vaccination schedule.

4. Healthcare personnel with a respiratory infection should avoid direct patient contact; if this is not possible, then a surgical mask should be worn while providing patient care and frequent hand hygiene should be reinforced.

7.8.7 Visitors

1. Written policies for visitors should be documented and made available.
2. Restriction to visitor numbers to two per patient at any one time is recommended.
3. Visitors are requested to practice hand hygiene before any contact with patient and should not sit on patient's bed.
4. Children under 12 years are not allowed into chemotherapy wards. All visitors must be able to follow appropriate hand hygiene and isolation precaution .(AIII)
5. To prevent the transmission of respiratory infections in the facility, the following infection prevention measures are implemented for all potentially infected persons (e.g., accompanying family members, caregivers, and visitors) with signs and symptoms of respiratory illness, including cough, congestion, rhinorrhoea, or increased production of respiratory secretions should not enter patient-care areas and are encouraged to wait outside the facility. (BII)

7.8.8 Surveillance cultures

1. Facility staff adhere to national requirements for reportable diseases and outbreak reporting.
2. Routine bacteria and fungal cultures of asymptomatic patients, environment, equipment and devices are not recommended.
3. Colonization with MRSA may be eradicated with 2% chlorhexidine or mupirocin (BIII). This may be indicated during outbreaks.
4. An outbreak e.g. twofold or greater increase in aspergillus infections during any 6 month period may suggest a lapse in infection control procedures and attention to environment or ventilation should be carefully evaluated

7.9 Pharmacy

Sterile Pharmaceutical Preparation

Introduction

Sterile preparations (eg Cytotoxic Drug, Parenteral Nutrition) are considered to be high risk category products due to increased risk and higher level of microbiological

contamination and also increased risk of systemic infections for products prepared in uncontrolled environments. Preparation should take place in well controlled environment using well established quality assurance-driven procedures.

Sterile Pharmaceutical Preparation Facilities

- i. All sterile pharmaceutical preparations should be produced in clean room facilities designed and built in accordance to Good Preparation Practice (GPP) requirements. The facilities which do not meet these requirements should work towards it.
- ii. The design, layout and specifications of the clean room facilities should follow the current guidelines approved by National Pharmaceutical Regulatory Agency.
- iii. Heating, Ventilation and Air-conditioning (HVAC) System should comply the requirement statement in the table below:

Clean Room Classification for sterile non-cytotoxic product

Clean Room Grade & Type Of Filter	Air Filter Efficiency %	Air Change Rate (Changes Per Hour)	Maximum Particle Count (>0.5 Um)		Max Of Viable Microbes Per Cubic Meter	Activities/ Purposes
			State	Per Meters		
A (ISO 5) HEPA filter	99.997	>120 Vertical flow: 0.3 m/sec + 20% Horizontal air flow: 0.45m/sec + 20%	At rest	3,520	<1	Laminar flow area for aseptic manipulation of sterile products. Space where sterile product is exposed
			In operation	3,520		
B (ISO 7) HEPA filter	99.995	>25	At rest	325,000	100	Clean room for preparation of sterile products. (less critical steps)
			In operation	3,250,000		

Note:
» Air chages rate are the key to cleaning a room effectively shall it get contaminated. Hence, the higher air changing rate, the better quality the room. High rate shall be selected where the air quality is continually challenged –e.g.dusty environment

Clean Room Classification for sterile cytotoxic product

Clean Room Grade & Type Of Filter	Air Filter Efficiency %	Air Change Rate (Changes Per Hour)	Maximum Particle Count (>0.5 Um)		Max Of Viable Microbes Per Cubic Meter	Activities/ Purposes
			State	Per Meters		
A (ISO 5) HEPA filter	99.997	>120 Vertical flow: 0.3 m/sec + 20% Horizontal air flow: 0.45m/sec + 20%	At rest	3,520	<1	Laminar flow area for aseptic manipulation of sterile products. Space where sterile product is exposed
			In operation	3,520		
B (ISO 7) HEPA filter	99.995	>25	At rest	325,000	100	Clean room for preparation of sterile products. (less critical steps)
			In operation	3,250,000		
D (ISO 8) Secondary filter	95	>20 (WHO)	At rest	3,250,000	200	Clean room for manufacturing sterile products-less critical steps. Also being used for non sterile manufacturing
			In operation	Not defined		

Note:

- » Air chages rate are the key to cleaning a room effectively shall it get contaminated. Hence, the higher air changing rate, the better quality the room. High rate shall be selected where the air quality is continually challenged –e.g.dusty environment

Storage, Receiving and Distribution Areas

- i. Storage areas shall be designed to ensure good storage conditions e.g. clean, dry and maintained. If special storage conditions are required (e.g. temperature and humidity) these shall be provided, checked and monitored regularly using appropriate devices.

Limits For Clean Room Control Parameters

a. Microbial Contamination Limit

Recommended limit for microbial contamination (a)				
Grade	air sample cfu/ m ³	Settle plates (diameter 90mm) cfu/4 hours (b)	Contact plates (55 mm diameter) cfu/ plate	Glove print 5 fingers cfu/glove
A	<1	<1	<1	<1
B	10	5	5	5
C	100	50	25	-
D	200	100	50	-

The frequency of monitoring depends on risk assessment of the respective facility

b. Temperature, Humidity and Air Pressure Differential Limit

Room	Temperature (°C)	RH (%)	Adjacent Room	Differential Pressure (kPa)
Preparation	20 ± 2	55 ± 5	Gowning	+ (10 -15)
Comp. Preparation	20 ± 2	55 ± 5	Changing	+ (10 -15)
Gowning	20 ± 2	55 ± 5	Changing	+ (10 -15)
Changing	20 ± 2	55 ± 5	Outside	+ (10 -15)

RH=Relative Humidity

Monitoring done daily especially before the procedure

Cleaning Procedure for clean room & equipment

- i. Adequate measures shall be taken against the entry of insects and other animals (pest control)
- ii. Production, storage and quality control areas shall be accessible to authorized personnel only
- iii. The Responsible Person (assigned by the Unit) is responsible for all matters regarding cleaning of the clean room. The Responsible Person shall provide training to the cleaning personnel (pharmacy personnel and/or any hospital personnel) to enable the personnel to perform cleaning duties
- iv. The Responsible Person shall supervise the cleaning procedures done by the trained personnel

- v. Ensure staff/ health care workers use appropriate PPE.
- vi. Ensure that all materials and equipment are in good condition. All materials entering clean room shall be wiped with disinfectant.
- vii. Disinfected materials and equipment shall be brought into the clean room through the pass box.
- viii. Cleaning Procedures (All cleaning done shall be recorded)

c. Recommended frequency of Cleaning

Frequency	Equipment/ area
Before and after production session	Laminar air flow cabinet (LAFC), Isolator/biosafety cabinet Stainless steel bench and trolley in preparation room
Daily (After production or reconstitution)	Floor, window and door knobs Pass box and clinical waste bins Stainless steel bench and trolley
Weekly	Walls and ceilings Gowning cabinet, changing room cabinety

- i. In the event of out of specification or serious problems such as Air Handling Unit (AHU) breakdown, high count of microbiological reading, or major renovation of clean room that jeopardizes the cleanliness of the room; thorough cleaning shall be done before any aseptic activity.
- ii. Should the monitored control parameters exceed the permitted limit, another round of thorough cleaning shall be done followed by monitoring until the results are within specified limit
- iii. All waste shall be disposed daily after each production and reusable cleaning materials shall be rinsed and sterilized before next use

Maintenance Procedure For Clean rooms & Equipment

- i. Procedure for Monitoring
 - a. Physical Monitoring for temperature, humidity and air pressure differential should be recorded daily before the procedure. Records need to be checked, analysed and verified.
 - b. Isolator glove integrity should be checked before the procedure.

- ii. Planned Preventive Maintenance (PPM) shall be done for equipment (FEMS, BEMS) according to the scheduled agreement. This maintenance can be carried out either by HSS or by appointed and accredited Third Party Testing Agent. A copy of all the reports shall be made available to the user

Personnel

All permanent personnel directly involved in the preparation of CDR and non-CDR preparations shall be trained and qualified

Quality Control

The sterile preparation of TPN by Pharmacy Department shall undergo quality control monitoring. Sampling is done as below:

- a. Samples taken for microbiological analysis shall be representative of the material being tested
- b. Samples shall be taken from the final container of the preparation prior to sealing of infusion port.
- c. Selection of the sample is based on 10% of total product. If total preparation is less than 10, at least one sample should be sent.
- d. The selected TPN bag should be marked in order for the ward staff to send the second sample for microbiological testing once the infusion completed.
- e. The amount of TPN sample should be at least 1-2 mls.
- f. Any growth from this sample should be informed immediately to the ward and pharmacist

7.10 Nephrology And Hemodialysis Unit

A. Haemodialysis

7.10.1 Haemodialysis unit water supply and air conditioning

1. The water supply to the dialysis machines must be supplied separately, and include standard filtration and reverse osmosis units (RO) to minimize the risk of exposure to pyrogens and endotoxins. The water used for haemodialysis should comply with the requirement of the Association of the Advancement Medical Instrumentation (AAMI) or the European Pharmacopoeia standards.
2. For high flux haemodialysis or haemodialfiltration, ultrapure water should be used.

3. The water treatment system should be designed to allow routine disinfection of the entire system, including the distribution system and the connections to the dialysis machine. The entire system should be disinfected at least once a month.
4. Microbial testing of the water samples (bacterial colony count and endotoxin level) should ideally be carried out at least once a month. The water samples should be taken before the reverse osmosis unit (RO), immediately after the RO and at the first, middle and final distribution point. Six monthly water analyses for chemical contaminants should be done.
5. Taps and sinks specification must be adjusted to avoid excessive splashing and spray.

7.10.2 The health of healthcare workers

1. All staff working in the unit should have immunisation to hepatitis B if not already immune.
2. Any staff that develops hepatitis must avoid direct patient care until serological markers and liver function tests indicate that they are no longer infective.
3. All staff must practice standard precautions to minimize percutaneous and mucous membrane exposure to the inoculation-risk viruses (Standard Precautions)

7.10.3 Hand hygiene

Hand hygiene practice

(Please refer to Chapter 3: Fundamental Principles of Infection Prevention)

7.10.4 Inoculation risks and body fluids

1. All staff must be aware of the infection risk from body fluids, blood, needles and sharps and must ensure that others are not exposed to these hazards.
2. Disciplinary action may be taken against any employee who is shown to be responsible for the careless disposal of hazardous items.
3. Discard sharps only into sharps bins.
4. Never fill sharps bins more than three-quarters full.
5. Do not leave needles and sharps lying around for somebody else to clear up.

6. Needles should not be re-sheathed but if re-sheathing is unavoidable then a safe one-handed technique must be used.
7. Blood spillages must be cleared up at once.
8. Wear non-sterile disposable latex gloves and a plastic apron.
9. Small spills may be covered with chlorine releasing granules and then cleared away with paper towels.
10. Large spills are best soaked up with paper towels first and then the area decontaminated with 1% hypochlorite.
11. Discard gloves, apron and paper towels into a yellow bag for incineration.
12. Splashes of blood or any other body fluid on to the skin should be washed off at once with soap and water.
13. Gloves should be worn for any procedure involving blood and body fluids or contact with broken skin or mucous membranes.
14. Staff with broken skin on their hands should wear gloves for handling any body fluid.
15. If an accident occurs, the protocol for dealing with sharps injuries and mucosal exposure must be followed immediately

(Please refer to Chapter 3: Fundamental Principles of Infection Prevention)

7.10.5 Screening of patients for HIV and hepatitis viruses

1. Until the HIV, Hepatitis B and Hepatitis C status of a dialysis patient is known; all patients must be treated as potentially infective.
2. Known positive patients should be dialysed in the unit using dedicated haemodialysis machine in a dedicated area or room.
3. All patients will be routinely screened for HIV, Hepatitis B and Hepatitis C before being accepted to the Hemodialysis programme.
4. All susceptible patients undergoing chronic haemodialysis treatment should be routinely screened for HIV, Hepatitis B and Hepatitis C once every three months.
5. Hepatitis Bs Antibodies titre should be checked 6 monthly.
(Please refer to Renal Replacement Therapy Clinical Practice Guideline 4th Edition)
6. In newly infected Hepatitis B infected patient, repeat Hepatitis Bs Antigen testing after 4-6 months and test for Hepatitis Bs antibody 6 months later to determine clinical outcome.
7. Confirmed positive Hepatitis C or HIV patients may not require repeat hepatitis C or HIV serological testing respectively.

7.10.6 Hepatitis B immunization

1. All patients who are susceptible to hepatitis B infection should be offered Hepatitis B vaccine followed by measurement of Hepatitis Bs antibodies, as early as possible in the course of their disease.
2. It should be noted that the antibody response rate in these patients is lower than in the general population and hence the vaccination dose and schedule should follow those recommended for haemodialysis patients (refer vaccine).
3. Patients who are Hepatitis Bs Antigen negative and have Hepatitis Bs antibody titre less than 100 IU/L shall be vaccinated

7.10.7 Disinfection and disposal at the end of haemodialysis

1. Staff must take care to avoid accidents with re-useable sharp instruments.
2. Gloves and an apron must be worn.
3. On completion of the haemodialysis treatment, all used dialysers and blood lines should be placed in a leak proof containers/bags when transporting them from the dialysis station to the reprocessing or disposal area.
4. All machines should be cleaned with a 0.1% hypochlorite solution.
5. Normal cleaning is adequate for the beds, mattresses, lockers and other furniture, unless contaminated by blood or other body fluids in which case the spillage procedure is followed.
6. Blood-stained linen must be placed in a special bag which is labelled "Biohazard".
7. Heavily blood-soaked linen should be placed in yellow bag for incineration.

7.10.8 Infection Control Precautions for all Patients

1. Disposable gloves **MUST** be worn whenever caring for the patient or when touching the patient's equipment (including the haemodialysis machine) at the haemodialysis station. The disposable gloves **MUST** be removed and hands **MUST** be washed between patients or dialysis stations.
2. Items taken into a dialysis station should be disposed of, dedicated for a single patient or cleaned and disinfected before using on other patients.

3. Dialysis chairs, table, haemodialysis machines etc MUST be cleaned and disinfected between patients.
4. Clean area should be clearly designated for handling and storage of medications, unused disposables, equipments and machines.
5. Venous and arterial pressure transducers filter/protector should be used and these should be changed between each patient and should not be reused.
6. Common cart should not be used to deliver medications or food to patients. If common cart has to be used, the cart must not be moved from one dialysis station to another and should remain in a designated area of sufficient distance from dialysis stations.

7.10.9 Management of Hepatitis B positive patients

1. Requires the same infection control precautions recommended for all haemodialysis patients.
2. Hepatitis B Ag positive patients should be dialysed in separate room using separate machines, equipment and supplies.
3. Staff caring for Hepatitis Bs Ag positive patients MUST not care for Hepatitis B
4. susceptible patients (Hepatitis Bs antibody negative) at the same time
5. Dialysers may be reprocessed but this MUST be done at dedicated reprocessing area and dedicated reprocessing machines

7.10.10 Management of Hepatitis C positive patients

1. Requires the same infection control precautions recommended for all haemodialysis patients
2. Hepatitis C positive patients should be dialysed in separate room using separate machines, equipment and supplies.
3. Staff caring for Hepatitis C positive patients MUST not care for Hepatitis C negative patients at the same time
4. Dialysers may be reprocessed but this MUST be done at dedicated reprocessing area and reprocessing machines
5. Hepatitis C positive patients who acquired sustained response after antiviral treatment should continue to be dialysed with machines at dialysis station dedicated for Hepatitis C positive patients. However, it is preferred that these patients are dialysed during the first shift.



7.10.11 Management of Hepatitis B and C positive patients

1. Patients with Hepatitis B and C co infection should be dialysed on a separate machine with separate equipment and supplies. When it is not possible, the patient shall be dialysed in a Hepatitis B isolation facility during the last shift.
2. For patients with Hepatitis B and Hepatitis C co infection, single use of dialyser is mandatory.

7.10.12 Management of HIV positive patients

1. It is necessary to have a dedicated machine for HIV-positive patients but all venous pressure transducers must be changed between patients.
2. Disposable dialysers should be used and dialysers should not be reprocessed.
3. Staff should wear eye glasses or visors to protect against the spray of blood that may occur when inserting needles into the patient.

7.10.13 Other infection control procedures

1. Standard 'no-touch' dressing changes and care of intravascular catheters should be performed according to the ward nursing procedures.
2. Patients with temporary or cuffed tunnelled dialysis catheters should be screened for carriage of Staphylococcus aureus, particularly methicillin-resistant strains (MRSA), and MRSA eradication should be attempted with a short course of nasal mupirocin and topical chlorhexidine.

B. Continuous Ambulatory Peritoneal Dialysis (PD)

7.10.14 Screening

1. Hepatitis B, Hepatitis C and HIV screening shall be performed before being accepted for treatment and 6 monthly.
2. Patients who are Hepatitis Bs Antigen negative and have Hepatitis Bs antibody titre less than 100 IU/l shall be vaccinated

7.10.15 Catheter insertion

1. Patients should be screened for staphylococcus (nasal swab) before surgical insertion of the catheter.
2. Carriers of Staph aureus (MSSA or MRSA) should be treated with nasal mupirocin and topical antiseptics in order to clear staphylococcal carriage before the catheter is inserted.
3. On the day of catheter insertion, the patient should shower using 4% aqueous chlorhexidine/ equivalent applied to their whole body to reduce skin flora.
4. Prophylactic antibiotics are indicated, at the discretion of the renal physician, before insertion of the catheter.
5. If the patient has concurrent skin sepsis, insertion must be delayed until the skin is normal.
6. If this is not possible, an antibiotic active against the causative organism should be administered just before catheter insertion and continued for 24 hours.
7. The intra-abdominal catheter must be inserted with full aseptic precautions.

7.10.16 Care of the PD system

1. The patient must receive adequate instruction on how to change the dialysis bags and how to maintain the exit with aseptic precautions at all times.
2. Patients should not immerse or wet the exit site during bathing. It is easier to keep the exit site dry by showering.
3. Only sterile pyrogen-free dialysate fluid designed for PD must be used.
4. If dialysis bags must be warmed, it should be done in a dry heating system and water baths must not be used.
5. Hands must be cleaned with chlorhexidine skin cleanser or alcoholic chlorhexidine.
6. The exit site must be cleaned and dressed daily using antiseptic solution 10% aqueous povidone-iodine or 0.5% chlorhexidine. The exit site should be patted dry after cleansing. Gentamicin cream Antibiotic cream should be applied to the exit site after cleansing.
7. All dried blood and secretions must be removed using fresh gauze swabs before each application of skin disinfectant. However it is



important not to forcibly remove crusts or scabs during cleansing as this would cause a break in the skin and may lead to exit site infection.

8. The exit site is covered with a sterile non-occlusive dressing (optional).
9. The connecting tubing and connectors must be changed approximately 6 monthly by the renal unit staff.
10. The catheter and proximal tubing must be securely anchored to the abdominal wall to prevent unnecessary movement around the exit site.
11. An infection control team shall be identified to activate, regulate, monitor and report infection control activities including staff training, case detection, documentation and audit activities.
12. Strict adherence to the guidelines for universal precautions by the staff shall be practised at all times.
13. PD unit should provide a clean area clearly designated for preparation of patient for an exchange; this area shall be disinfected in between patients.

7.10.17 Management of PD effluent in Hepatitis B/ C/ HIV patients

1. Dispose of PD effluent fluid in the toilet bowl and disinfect with 50 mls of sodium hypochloride. Flush the toilet. Any spillage is to be clean with a spillage kit.
2. Disposal of effluent bag: soak each bag in 50 mls of sodium hypochloride in 1 gallon of water for 2 minute. All the effluent bags for the day are placed in 2 layers of black garbage bag and pour in 50 mls of sodium hypochloride. The bag is tied up and disposed off.

7.10.18 Management Of The Infective Patient (Hepatitis B /C /HIV)

Due to the nature of haemodialysis treatment and the likelihood of receiving multiple blood transfusions, long term haemodialysis patients have a higher risk of acquiring Hepatitis B virus (HBV) and Hepatitis C virus (HCV) infections compared to the normal population.

Once infected these patients are more likely to become chronic carriers. Hence, the seroprevalence of HBV and HCV in haemodialysis patients is higher than in the general population.

1. Even with meticulous and regular sterilization procedures for haemodialysis machines and disposable components and practice of standard precautions against infections from blood products and body fluids, the risk of acquiring HBV and HCV with haemodialysis treatment remains. Therefore it is prudent to adopt additional measures to reduce the risk:
2. All patients subjected to chronic haemodialysis treated must have their blood tested for Hepatitis B, Hepatitis C and HIV every 3 months. Patients who are positive for Hepatitis Bs Antigen should be dialyzed with separate machines at separate haemodialysis station and not shared by seronegative patients.

The following rooms/facilities used for Hepatitis Bs Antigen positive patients should be separated from HbsAg negative patients. For examples:

- a) Reprocessing area for disposable
 - b) Dialysis treatment room.
3. Patients who are Hepatitis C positive should also be dialysed with dedicated machine at dedicated haemodialysis station and not to be shared with Hepatitis C negative patients. The dialysis treatment room and the reprocessing area should be separated from Hepatitis C negative patients.
 4. For HIV positive patients, disposable should not be re-used and a separate room or home haemodialysis peritoneal dialysis is preferred. The disposal of bloodlines, dialysers and dialysate is made according to the recommendation of the Ministry of Health.
 5. Seronegative patients should be immunised against Hepatitis B (if HbsAb-ve) using double dose of vaccine 40ug of vaccine at 0, 1 and 6 months with Recombivax HB® or at 0,1,2 and 6 months with Engerix B®. Check Hepatitis Bs Antibody after 1-2 months post vaccination. Staff of haemodialysis units are routinely immunized.
 6. Patients positive for Hepatitis B / C or co infection should be monitored for evidence of chronic liver disease and its complication with LFT every 3 months and surveillance for hepatocellular carcinoma.

7.10.19 Prevention Of Complications: Infection

Infections Control Measures

Staff and patient education should include instruction on infection control measures for all haemodialysis access sites.



Rationale

In haemodialysis patients, poor personal hygiene is a risk factor for vascular access site infections. Therefore, haemodialysis patients with poor personal hygiene habits should be taught how to improve and maintain their personal hygiene.

In addition, there is a higher rate of infections in haemodialysis patients when new or inexperienced dialysis staff manipulates the patient's vascular access. Because of this, all dialysis staff should be trained in infection control procedures. Documenting educational materials and objectives must be part of patient's records and staff orientation records.

Tracking the occurrence of infections can help identify the source and allow corrective action to be taken. Ongoing quality assurance, risk management, or CQI efforts should be in place to monitor the incidence of infections, to evaluate the response to patient and staff education, and identify future educational needs.

7.11 Laboratory

7.11.1 General Principles

In this topic, references are made to the relative hazards of infective microorganisms by risk group (WHO Risk Groups 1, 2, 3 and 4). This risk group classification is to be used for laboratory work only. This risk group classification is to be used for laboratory work only. Table 7.1 describes the risk groups.

Table 7.1 Classification of infective microorganisms by risk group

Group	Risk	Type of infective organism
1	No or low individual and community risk	A microorganism that is unlikely to cause human or animal disease.
2	Moderate individual risk, low community risk	A pathogen that can cause human or animal disease but is unlikely to be a serious hazard to laboratory workers, the community, livestock or the environment. Laboratory exposures may cause serious infection, but effective treatment and preventive measures are available and the risk of spread of infection is limited.

3	High individual risk, low community risk	A pathogen that usually causes serious human or animal disease but does not ordinarily spread from one infected individual to another. Effective treatment and preventive measures are available
4	High individual and community risk	A pathogen that usually causes serious human or animal disease and that can be readily transmitted from one individual to another, directly or indirectly. Effective treatment and preventive measures are not usually

- * Laboratory facilities are designated as Biosafety Level 1 (basic), Biosafety Level 2 (basic), Biosafety Level 3 (containment), and Biosafety Level 4 (maximum containment).
- * Biosafety level designations are based on a composite of the design features, construction, containment facilities, equipment, practices and operational procedures required for working with agents from the various risk groups.
- * The assignment of an agent to a biosafety level for laboratory work must be based on a risk assessment. Such an assessment will take the risk group as well as other factors into consideration in establishing the appropriate biosafety level.

Table 7.2 Summarizes the facility requirements at the four biosafety levels.

	Biosafety Level			
	1	2	3	4
Isolation of laboratory	No	No	Yes	Yes
Room sealable for decontamination	No	No	Yes	Yes
Ventilation:				
• Inward airflow	No	Desirable	Yes	Yes
• controlled ventilation system	No	Desirable	Yes	Yes
• HEPA-filtered air exhaust	No	No	Yes/ No	Yes
Double-door entry	No	No	Yes	Yes
Airlock	No	No	No	No

Airlock with shower	No	No	No	Yes
Anteroom	No	No	Yes	-
Anteroom with shower	No	No	Yes/ No	No
Effluent treatment	No	No	Yes/ No	Yes
Autoclave:				
• on site	No	Desirable	Yes	Yes
• in laboratory room	No	No	Desirable	Yes
• double-ended	No	No	Desirable	Yes
Biological safety cabinet	No	Desirable	Yes	Yes
Personnel safety monitoring capability _d	No	No	Desirable	Yes

Thus, the assignment of a biosafety level takes into consideration the organism (pathogenic agent) used, the facilities available, and the equipment practices and procedures required to conduct work safely in the laboratory.

7.11.2 Guidance and Recommendations

Diagnostic and health-care laboratories (public health, clinical or hospital-based) must all be designed for Biosafety Level 2 or above. As no laboratory has complete control over the specimen it receives, laboratory workers may be exposed to “high risk group” organisms. Therefore, standard precautions should always be adopted and practiced, as well as to promote good (i.e. safe) microbiological techniques (GMT)

7.11.3 Code of Practice

This code is a listing of the most essential laboratory practices and procedures that are basic to GMT. Each laboratory should adopt a safety or operation manual that identifies known and potential hazards, and specifies practices and procedures to eliminate or minimize such hazards. The most important concepts are listed below.

7.11.3.1 Access

1. The international biohazard warning symbol and sign must be displayed on the doors of the rooms where microorganisms of Risk Group 2 or higher risk groups are handled (Table 7.1).

2. Only authorized persons should be allowed to enter the laboratory working areas.
3. Laboratory doors should be kept closed.
4. Children should not be authorized or allowed to enter laboratory working areas.

7.11.3.2 Personal protection

1. Laboratory coveralls, gowns or uniforms must be worn at all times. The coat/gown should be removed before leaving the laboratory and placed on the area provided.
2. Appropriate gloves must be worn for all procedures that may involve direct or accidental contact with blood, body fluids and other potentially infectious materials. After use, gloves should be removed aseptically and hands must then be washed.
3. Personnel must wash their hands after handling infectious materials and before leaving the laboratory working areas.
4. Protective devices must be worn whenever necessary to protect the eyes and face from splashes, impacting objects and sources of artificial ultraviolet radiation.
5. Any cuts, abrasions or other skin lesions must be properly covered to protect them against contamination before starting work.
6. Eating, drinking, smoking, applying cosmetics and handling contact lenses is prohibited in the laboratory working areas.
7. Storing human foods or drinks anywhere in the laboratory working areas is prohibited.

7.11.3.3 Procedures

1. Materials must not be placed in the mouth.
2. Any technical procedures should be performed in a way that minimizes the formation of aerosols and droplets.
3. The use of hypodermic needles and syringes should be limited. They must not be used as substitutes for pipetting devices.
4. All spills, accidents and overt or potential exposures to infectious materials must be reported to the laboratory supervisor. A written record of such accidents and incidents should be maintained.
5. A written procedure for the clean-up of all spills must be developed and followed.

6. Contaminated liquids must be decontaminated (chemically or physically) before discharge to the sanitary sewer. An effluent treatment system may be required, depending on the risk assessment for the agent(s) being handled.
7. Written documents that are expected to be removed from the laboratory need to be protected from contamination while in the laboratory.

7.11.3.4 Laboratory working areas

1. The laboratory should be kept neat, clean and free of materials that are not pertinent to the work.
2. Work surfaces must be decontaminated after any spill of potentially dangerous material. At the end of the working day all working surfaces must be decontaminated.
3. All contaminated materials, specimens and cultures must be decontaminated before disposal. Decontamination shall be done for any reusable materials
4. Packing and transportation must follow applicable national and/or international regulations.

7.11.3.5 Biosafety management

1. It is the responsibility of the laboratory director (the person who has immediate responsibility for the laboratory) to ensure the development and adaption of a biosafety management plan and a safety or operations manual.
2. The laboratory supervisor (reporting to the laboratory director) should ensure that regular training in the laboratory safety is provided.
3. Personnel should be advised of special hazards, and required to read the safety or operation manual and follow standard practices and procedures. The laboratory supervisor should make sure that all personnel understand these. A copy of the safety or operations manual should be available in the laboratory.
4. There should be an arthropod and rodent control programme.
5. Appropriate medical evaluations, surveillance and treatment should be provided for all personnel in the case of need, and adequate medical records should be maintained.

7.11.4 Laboratory Design And Facilities

Special attention should be paid to the conditions that are known to pose safety problems. These include:

- Formation of aerosols
- Work with large volumes and/or high concentrations of microorganism
- Overcrowding and too many equipments
- Infestation with rodents and arthropods
- Unauthorized entrance
- Workflow: use of specific samples and reagents

7.11.4.1 Design features

1. Ample space must be provided for the safe conduct of the laboratory work and for cleaning and maintenance.
2. Walls, ceilings and floors should be smooth, easy to clean, impermeable to liquids and resistant to the chemicals and disinfectants normally used in the laboratory. Floors should be slip-resistant.
3. Bench tops should be impervious to water and resistant to disinfectants, acids, alkalis, organic solvents and moderate heat.
4. Illuminations should be adequate for all activities. Undesirable reflections and glare should be avoided.
5. Laboratory furniture should be sturdy. Open spaces between and under benches, cabinets and equipment should be accessible for cleaning.
6. Storage space must be adequate to hold supplies for immediate use and thus prevent clutter in bench tops and in aisles. Additional long-term storage space, conveniently located outside the laboratory working areas, should also be provided.
7. Space and facilities should be provided for the safe handling and storage of solvents, radioactive materials, and compressed and liquefied gases.
8. Facilities for storing outer garments and personal items should be provided outside the laboratory working areas.
9. Facilities for eating and drinking and for rest should be provided outside the laboratory working areas.
10. Hand-washing facilities, with running water if possible, should be provided in each laboratory room, preferably near the exit door.
11. Doors should have vision panels, appropriate fire rating, and preferably be self-closing.
12. At Biosafety Level 2, an autoclave or other means of decontamination should be available in appropriate proximity to the laboratory.

13. Safety systems should cover fire, electrical emergencies, emergency shower and eyewash facilities.
14. First-aid areas or rooms suitable equipped and readily accessible should be available
15. In the planning of new facilities, consideration should be given to the provision of mechanical ventilation systems that provide an inward flow of air without recirculation. If there is no mechanical ventilation, windows should be able to be opened.
16. Considerations should be given to the installation of a separate air conditioning system to control the heat gain from equipment with high heat outputs, e.g. fridges and incubators. It is preferable to use a sealed type of unit that recirculates cooled air into the room.
17. A dependable supply of good quality water is essential. There should be no cross-connections between sources of laboratory and drinking water supplies. An anti-backflow device should be fitted to protect the public water system.
18. There should be reliable and adequate electricity supply and emergency lighting to permit safe exit. A stand-by generator is desirable for the support of essential equipment such as incubators, biological safety cabinets, freezer, etc.
19. There should be a reliable and adequate supply of gas. Good maintenance of the installation is mandatory.

7.11.5 Laboratory Equipment

Technically with good procedures and practices, the use of safety equipment will help to reduce risks when dealing with biosafety hazards. The laboratory director should ensure that adequate equipment is provided and that it is used properly. Equipment should be selected to take account of certain general principles, i.e. it should be:

- i. Design to prevent or limit contact between the operator and the infectious material.
- ii. Constructed of materials that are impermeable to liquids, resistant to corrosion and meet structural requirements.
- iii. Fabricated to be free of burrs, sharp edges and unguarded moving parts.
- iv. Designed, constructed and installed to facilitate simple operation and provide for ease of maintenance, cleaning, decontamination and certification testing; glassware and other breakable materials should be avoided, whenever possible.

7.11.5.1 Essential biosafety equipment

1. Biological safety cabinets Class II, to be used whenever:
 - a. All infectious materials are handled; such materials may be centrifuged in the open laboratory if sealed centrifuge safety cups are used and if they are loaded and unloaded in a biological safety cabinet.
 - b. There is an increased risk of airborne infection.
 - c. Procedure with a high potential for producing aerosols are used; these may include centrifugation, grinding, blending, vigorous shaking or mixing, sonic disruption and opening of containers of infectious materials
2. Electric transfer loop incinerators may be used inside the biological safety cabinet to reduce aerosol production.
3. Screw-capped tubes and bottles.
4. Autoclaves or other appropriate means to decontaminate infectious materials.
5. Petri dishes must be placed in racks or baskets, both for transport and storage.
6. Plastics disposable Pasteur pipettes, whenever available, to avoid glass.
7. Equipment such as autoclaves and biological safety cabinets must be validated with appropriate methods before being taken into use. Recertification should take place at regular intervals, according to the manufacturer's instructions.

7.11.6 Health And Medical Surveillance

The employing authority, through the laboratory director, is responsible for ensuring that there is adequate surveillance of the health of laboratory personnel. The objective of such surveillance is to monitor for occupationally acquired diseases. Appropriate activities to achieve these objectives are:

- Provision of active or passive immunization where indicated.
- Facilitation of the early detection of laboratory-acquired infections.
- Exclusion of highly susceptible individuals (e.g. pregnant woman or immunocompromised individuals) from highly hazardous laboratory work.
- Provision of effective personal protective equipment and procedures.

(Please refer to *Guidelines for the surveillance of laboratory workers handling microorganism at Biosafety Level 2*)

- i. A pre-employment or pre-placement health check is necessary. The person's medical history should be recorded and a targeted occupational health assessment performed.

- ii. Records of illness and absence should be kept by the laboratory management

7.11.7 Waste Disposal and Decontamination

Identification and separation system for infectious materials and their containers should be adopted. Categories should include:

- i. Non-contaminated (non-infectious) wastes can be reused or recycled or disposed of as general, “household”.
- ii. Contaminated (infectious) “sharps” – hypodermic needles, scalpels, knives and broken glass. These should always be collected in puncture-proof containers fitted with covers and treated as infectious.
- iii. Contaminated material for decontamination by autoclaving and thereafter washing and reuse or recycling.
- iv. Contaminated material for autoclaving and disposal.
- v. Contaminated material for direct incineration.

7.11.7.1 Disposal of Sharps

To prevent needle stick injury, needles must not be re-sheathed. Needles must not be bent or broken by hand. Sharps must be placed into a sharps container as soon as possible after use. The person who has used the sharp is responsible for its immediate safe disposal following its use. This must be at the point of use. The sharps container should be within arm’s length.

Sharps containers need to be rigid, impervious containers which are discarded when 2/3 full

7.11.8 Chemical, Fire, Electrical, Radiation and Equipment Safety

A breakdown in the containment of pathogenic organisms may be indirect result of chemical, fire, electrical or radiation accidents. It is therefore essential to maintain high standards of safety in these fields in any microbiological laboratory.

7.11.9 Transport of Infectious Substances

Transport of infectious and potentially infectious materials is subject to strict national and international regulations. These regulations describe the proper use of packaging materials, as well as other shipping requirements.

Laboratory personnel must ship infectious substances according to applicable transport regulations. Compliance with the rules will:

- i. Reduce the likelihood that packages will be damaged and leak, and thereby
- ii. Reduce the exposures resulting in possible infections
- iii. Improve the efficiency of package delivery.

The basic triple packaging system:

- i. This packaging system consists of three layers: the primary receptacle, the secondary packaging and the outer packaging.
- ii. The primary receptacle containing the specimen must be watertight, leak proof and appropriately labelled as to content. The primary receptacle is wrapped in enough absorbent materials to absorb all fluid in case of breakage or leakage.
- iii. A second water tight, leak proof packaging is used to enclose and protect the primary receptacle (s). Several wrapped primary receptacles may be placed in a single secondary packaging. Volume and/or weight limits for packaged infectious substances are included in certain regulatory texts.
- iv. The third layer protects the secondary packaging from physical damage while in transit. Specimen data forms, letters and other types of information that identify or describe the specimen and identify the shipper and receiver, and any other documentation required must also be provided.

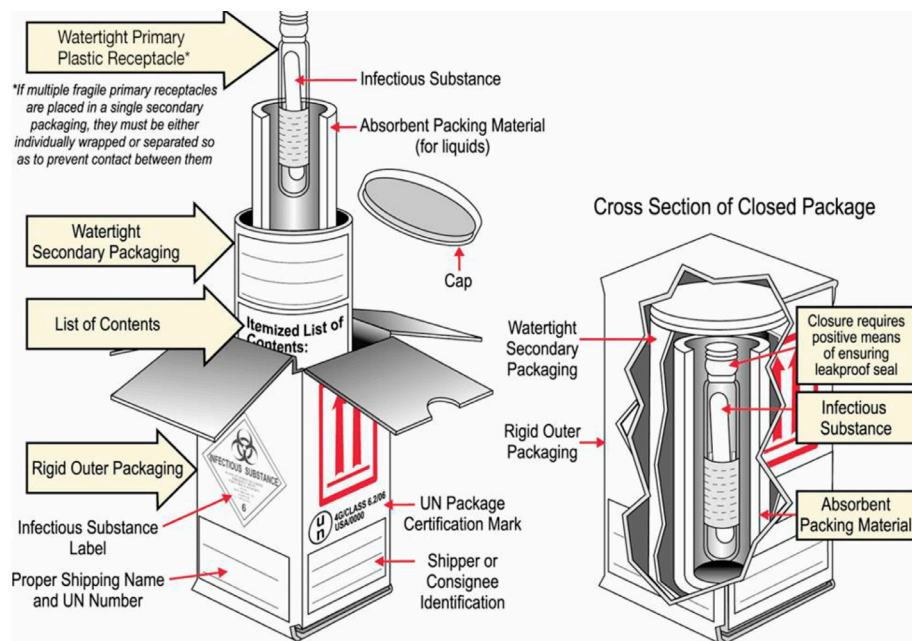

Guidance for Collection, Transport, and Submission of Specimens for Ebola Virus Testing in the United States CDC 2017

7.11.10 Vaccinations

Vaccinations are required for all staff/students who have contact with clients and those working in laboratories and departments of forensic medicine/morgues who may come in contact with blood, body substances or infectious materials. All the vaccination policy using our national Vaccination guidelines (Please refer to MOH policy regarding vaccination).

Staff members and students are expected to maintain their own screening and vaccination records and have them available for inspection. It is the supervisor's responsibility and duty of care to ensure that all staff and students have received the required vaccinations (and provided evidence of protection) depending on the type of work to be undertaken. Staff and students must not be permitted to undertake work with clients or to perform tasks that may involve contact with blood, body substances or infectious materials until they have provided appropriate vaccination records.

7.11.11 Microbiology Accident Emergency Plan:

- i. Notify supervisor
NOTE: Gloves are to be worn during all clean-up procedures.
- ii. Accident and spills:
 - a. "Dry" spills (overturned or broken culture plate) with no significant aerosol formation Evacuation of room probably not indicated. Flood area with a tuberculocidal disinfectant, such as 10% bleach. Soak up disinfectant and contaminated material with an absorbent material (sand, paper towels), place in a Biohazard container, and seal the container. The spill area is thoroughly washed down with a tuberculocidal disinfectant after the contaminated material has been removed. Biohazard bag is to be placed into another bag for removal to the incinerator.
 - b. Liquid spills on bench or floor:
NOTE:
 - If significant aerosols were formed, the area is to be evacuated and not reentered for at least one hour.
 - Cover the spill with an absorbent material (as above). When absorption is complete, the absorbent and contaminated material should be placed in a Biohazard bag for disposal as noted above.

- The entire spill area should be thoroughly washed down with a tuberculocidal disinfectant (as above) after the contaminated material has been removed.
- c. Centrifuge spills:
Shut off instrument. Do NOT open the centrifuge for at least one hour. In addition to gloves, the person responsible for clean-up of the area is to wear a mask and protective clothing.
If liquids are present, absorbent materials should be used as noted above. After removal of contaminated material, the instrument is to be thoroughly cleaned with a tuberculocidal disinfectant before resuming work.
- NOTE: Traffic should be minimized in the area during clean-up procedures.
- d. Spills in incubators or other closed areas:
Absorbent material is to be used as above if liquids are present. The organic material must be removed as thoroughly as possible before disinfection or sterilization can occur. If routine cleanup is not possible, the unit may have to be decontaminated by means of a sterilizing gas such as ethylene oxide in Central Sterile Supply.
The spill area is to be thoroughly washed after the contaminated material has been removed.

7.11.12 Training Programme

A continuous, safety training programme is essential to maintain safety awareness among laboratory and support staff. Laboratory supervisors, with the assistance of the biosafety officer and other resource persons, play the key role in staff training. The effectiveness of all safety and health training, depends on management commitment, motivational factors, adequate initial job training, good communications, and ultimately the organization's goals and objectives.

7.12 Food Services

7.12.1 Introduction

Hospital food service management involve planning, procurement of food items, storage, food preparation and serving of food to patients, mother accompanying child (MAC), doctors and other allied health professionals.



Hospital patients are particularly vulnerable to food poisoning. Thus, every quality control effort should be implemented to ensure foods served to patients are free from contamination.

Continuous monitoring, process control and audit are part of food service activities to ensure quality and safety. All involved in food service from preparation to serving of food should adhere to good hygiene standards.

Food quality and hygiene standards as in Good Manufacturing Practice (GMP) and Hazard Analysis and Critical Control Point (HACCP) should be considered in management policies to identify, evaluate and control food safety related hazards.

7.12.2 Facilities and Equipment Requirements

Facilities & Equipment	Requirement
Building	The building should be designed and constructed according to its intended use, easy to maintain, clean and where appropriate, able to be disinfected. Suitable ceiling, lighting, walls, floor, sinks, drainage, doors and windows are essential to control infection.
Water Supply	An adequate clean water supply is needed for food preparation and cleaning of utensils and equipments.
Equipment/Utensils	Equipment/utensils used should be of impermeable materials that designed and constructed for adequate cleaning, sanitisation and maintenance to avoid food contamination. Equipment should be designed to achieve the food temperature required. Separate sinks should build for hand washing, food preparation and cleaning of equipment/utensils.
Storage	Separate storage is needed for different uses. Food items, chemicals and equipment/utensils should be stored in separate area to avoid cross contamination of food. Dry food store is needed for non perishable items while chiller and freezer required for perishable food items.

Washing Area	Washing area for trolley, crockery and cooking utensils should be separated from food preparation area.
Refuse and Disposal Area	Special refuse and disposal area should be separated from food preparation and washing area. Adequate number of bins with close fitting lids and covers are needed. Food wastes should be disposed regularly to prevent contamination.
Toilets/ Changing Room/ Hand Washing Facilities	Toilet/ changing room/ hand washing facilities should be made available for food service staffs and equipped with tissues, soap, bins and posters on hand hygiene.

7.12.3 Operation System Requirements

Operation System	Requirement
Purchasing & Receiving	<p>Purchase food from a safe and recognised source.</p> <p>Food containers and vehicles should be clean and free from contamination and comply with standard temperature. Chilled food should be refrigerated from 0°C to 10°C and frozen food items below -18°C. Food received should be within expiry date and good in condition.</p> <p>The person involved in receiving of food items should wear hair net, apron, close shoes and practice hand hygiene.</p>
Storage	<p>Food storage should be clean, covered, and in compliance with standard temperature and storage management procedures. Chilled food should be stored from 0°C to 10°C and frozen food items below -18°C. Refrigerator and freezer temperatures should be monitored and recorded daily. Store raw and cooked food separately.</p> <p>Practice First In First Out (FIFO) to avoid decomposition, infestation, contamination and to ensure food used before expiry.</p>

<p>Preparation</p>	<p>Frozen foods should be thawed in an area with temperature below 10°C or under running water to prevent contaminating work surfaces or other food. Use thawed food immediately or chilled before cooking/ serving and never refreeze it.</p> <p>Use separate clean preparation tables and utensils for raw and cooked food. Use separate labelled or colour coded knives, chopping board and towels to avoid cross contamination.</p> <p>Food should be cooked evenly throughout till well done at the right temperature to avoid food borne illnesses.</p>
<p>Holding</p>	<p>Proper holding temperature prevents the growth of harmful microorganisms. Cooked food should be kept above 60°C in preheated holding equipment and cold food should be kept below 10°C. Reheating of hospital food is prohibited.</p>
<p>Distribution at Kitchen</p>	<p>All food leaving the kitchen should be checked for quality and temperature. Serve food with clean tongs, scoops, or gloves to avoid direct contact with food.</p> <p>Clean and sanitise food crockery and cutleries, containers, trolleys and vehicles used for distribution of food.</p> <p>If heated trolleys are available, it should be pre-heated to maintain food temperature above 60°C. Cold food should be transported in insulated or refrigerated container.</p> <p>Person involved in distribution of food should practise hand hygiene and wear Personal Protective Equipment (PPE) such as cap, mask, gloves, apron and close shoes.</p>

<p>Serving of Food</p>	<p>Food should be served in crockery with lid to patients within four (4) hours after cooking to prevent the growth of harmful microorganisms and cross contamination.</p> <p>Staff involved in serving food must practise hand hygiene and wear PPE (cap, mask, apron, gloves and close shoes).</p> <p>Ward pantry should be clean, well ventilated and equipped with hot and cold washing facilities.</p> <p>Patients at isolation rooms/wards can also be served with similar crockeries as other patients.</p> <p>Disposable containers Is recommended to be used for patients with transmissible based precautions</p> <p>Disposable containers SHOULD be used for patients with public health emergencies of international concern (e.g. MERS-CoV, Ebola, SARS)</p>
<p>Washing and Drying</p>	<p>All crockery, cutleries and containers should be washed using clean hot water and appropriate detergent including those used to serve patients at isolation rooms/wards.</p> <p>Clean and sanitise food trolleys daily immediately after food distribution.</p> <p>Crockery, cutleries and containers should be kept at clean area at room temperature for drying.</p>

7.12.4 Other Food Services Requirements

Item	Requirement
<p>Health Status</p>	<p>Medical examination and typhoid vaccination is mandatory for all food handlers including food service staff. Food service staff with diarrhoea, vomiting, skin rashes, boils or other skin lesions, discharge from ear, eye or nose should abstained from preparation and handling of food.</p>

Personal Hygiene	Food service staff must practice hand hygiene, wear proper clean uniform, appropriate PPE such as apron, hair net, mask and closed shoes throughout food service operation to prevent food contamination.
Temperature Monitoring	Time and temperature of cooking, cooling, processing and storage should be monitored, controlled and recorded routinely.
Maintenance and Sanitation	Ceiling, lighting, walls, floor, toilets, sinks, drainage, doors, windows, equipments and working tables should be regularly cleaned, maintained and repaired as required.
Food/ Water Sampling	Scheduled food and water sampling should be done to ensure food/water safety.
Swab	Scheduled swab should be done for equipment/utensils/ gloves/hand to control cross contamination.
Pest Control	Scheduled pest control activities should be done periodically at food premise, equipment and surrounding areas.
Recall Procedures	Recall procedures should be in place to enable effective product recall when there is food safety related incidence.
Audit	Regular audits should be planned and conducted to ensure compliance to food safety activities.
Visitors	Visitors must declare their health status and compulsory to wear PPE before entering the premises.
Training	Food service staff compulsory to undergo basic food handler training. Training programs should routinely reviewed and updated when necessary.

8

ANTIMICROBIAL RESISTANCE (AMR)

Introduction

The introduction of antimicrobial agents has contributed to the reduction of infectious diseases as the major cause of premature death. Treatment with antimicrobial agents seems so effective and safe that they are sometimes prescribed for dubious indications and for longer than necessary, with little concern for adverse effects and the development of resistance.

In the last 40 years, the prevalence of multidrug-resistant microorganisms (e.g. extended spectrum beta-lactamase-producing *Enterobacteriaceae*) has risen alarmingly. There is evidence that overall rates of antimicrobial resistance correlate with the use of antimicrobials. Certain antimicrobials like quinolones promote the emergence of resistance more than others especially in MRSA and Gram-negative bacilli.

The emergence of AMR leads to resistance of the existing first-line antimicrobials which leads to usage of broad spectrum and second line antimicrobials. As more resistance is acquired, we are eventually left without any effective drug therapies. Thus AMR has negative impacts on patient outcomes in such a way that it poses a major threat for patient safety, increases health expenditure and loss of treatment options for common infections.

Antimicrobial Stewardship (AMS) program has been developed and implemented as a response to these issues. AMS is a coordinated systematic approach to improve the appropriate use of antimicrobials in clinical settings. It promotes the optimal antimicrobial usage by selecting the right choice of antimicrobial, right route of administration, right dose, right time, right duration and minimize harm to the patient and future patients.

Ongoing monitoring and prospective audits have been shown to improve patient care, decrease unnecessary antimicrobial use and microbial resistance and reduce pharmacy expenditures. AMS has demonstrated 22% - 36% decrease in antimicrobial use.

8.1 Surveillance

8.1.1 Antimicrobial Resistance (AMR) Surveillance

8.1.1.1 Antimicrobial resistance surveillance

- Involves systematic active collection, analysis and interpretation of susceptibility data in order to detect or monitor any abnormal phenotypes that may impose a threat to patients in hospital as well as to general public health.
- Provides information on the epidemiology of antibiotic resistance in hospital settings and the community.
- Allows monitoring of changes or variation in antibiotic resistance related to certain health facilities/wards.
- Provides the timely dissemination of the data to the respective clinicians aimed at formulating and implementing remedial actions.

Surveillance Process

- Involves collection of Antibiotic Susceptibility Test (AST) results undertaken by microbiology laboratories on microorganisms isolated from clinical samples.
- The interpretive criteria for susceptibility are based on standardized guidelines as outlined by CLSI. When the interpretation zones are not available in CLSI, EUCAST guidelines should be used.
- Correlation of these surveillance data with demographic and clinical data will give insight into the magnitude of antimicrobial resistance in healthcare settings and community.
- Periodical surveillance reports will be provided to the national committee and respective healthcare facilities.

8.1.1.2 AMR surveillance activity

8.1.1.2.1 National Surveillance of Antimicrobial Resistance, Malaysia (NSAR)

The objective is to gather susceptibility data of all clinical isolates based on the AST on clinical samples from selected healthcare facilities. Data is collected from January until December every year, analysed and reported based on the targeted organisms as listed below.

- Staphylococcus aureus*

- ii. *Streptococcus pneumoniae*
- iii. *Enterococcus species*
- iv. *Acinetobacter baumannii*
- v. *Escherichia coli*
- vi. *Klebsiella pneumoniae*
- vii. *Pseudomonas aeruginosa*
- viii. *Salmonella typhi*
- ix. *Salmonell sp*
- x. *Neisseria gonorrhoea*

The analysis is based on one isolate per patient using the WHONET software and will only be carried out if there are 30 or more isolates tested against the selected antibiotics to ensure that the results is based on sufficient number of samples.

8.1.1.2.2 Surveillance on Multidrug Resistant Organism (MDRO)

MDRO surveillance is the continuous active monitoring of the incidence of specified organisms of clinical interests. The objective of this surveillance program is to determine the rate and trend of targeted MDRO in all hospitals in Malaysia using standardized laboratory and clinical criteria. This will allow for early prevention, detection of an outbreak, timely investigation and institution of control measures. This program measures both healthcare associated infections and colonization that are attributed to the MDRO of interest.

The MDRO under surveillance are:

- i. Methicillin-resistant *S.aureus* (MRSA)
- ii. Extended Spectrum Beta-Lactamase (ESBL) producing *Klebsiella pneumoniae*
- iii. Extended Spectrum Beta-Lactamase (ESBL) producing *Escherichia coli*
- iv. Multidrug resistant *Acinetobacter baumannii*
- v. Vancomycin resistant *Enterococci* (VRE)
- vi. Carbapenem resistant *Enterobacteriaceae* (CRE)

This surveillance highlights the incidence of MDRO per number of admissions and per 1000 patient days.



8.1.1.3 Point Prevalence Survey (PPS) on Healthcare-Associated Infections (HCAI) and antibiotic utilisation

Point prevalence survey on HCAI is a count of the number of patients with a HCAI on a particular day, as a proportion of the total number of patients who are hospitalised at that particular time. The objective of PPS on HCAI and antibiotic utilization is to estimate the total burden (prevalence), characteristic of HCAI, antibiotic usage, frequency of invasive procedures and other predisposing factors of HCAI. The PPS on HCAI and antibiotic utilization are coordinated at national level by MOH and implementation shall follow the standard protocol from MOH

8.2 Antibiotic Surveillance

Surveillance of antimicrobial use can provide insights on how antimicrobials are being used in healthcare settings. Data from this surveillance are used to reflect the difference in prescribing patterns of different hospitals and departments. Antibiotic utilisation surveillance at the national level has been established in selected Malaysian hospitals since 2001. Currently, it is known as National Surveillance on Antibiotic Utilisation (NSAU). The participating hospitals include hospitals under the Ministry of Health (MOH), Ministry of Higher Education (MOHE), Ministry of Defence (MinDef) and certain private hospitals. The surveillance has been expanded to the primary care setting since July 2015.

NSAU aims to:

- i. Collect national data on antibiotic utilisation in hospitals and primary care facilities.
- ii. monitor trends of antibiotics utilisation
- iii. Report antibiotic utilisation data at local, national, regional and international levels.
- iv. Use antibiotic utilisation data to guide interventions at facility level.
- v. Compare the use of antibiotics among healthcare facilities.
- vi. Establish national benchmark for antibiotic usage.

The detailed description on methodology and list of healthcare facilities included in NSAU are available in NSAU brief and manual for data collection.

**** Healthcare facilities which are not included in NSAU shall conduct antibiotic surveillance at their facility level using the same methodology.***

At facility level, data from antibiotic surveillance shall be reported in the Hospital/District Infection and Antibiotic Control Committee Meeting and subsequently will be tabled in the State Infection and Antibiotic Control Committee Meeting.

Upon receiving the report, the respective healthcare facility/department with high usage of antibiotics shall provide feedback to the National/Hospital/District Infection and Antibiotic Control Committee on antimicrobial control practice and their strategies to improve control on the antimicrobial of concern.

8.3 Policy & Guidelines On Antimicrobial Stewardship

8.3.1 Antimicrobial policy

Establishment of an antimicrobial policy is to provide better care for patients and to combat antimicrobial resistance by promoting rational use of antimicrobials among prescribers. Principles of antibiotic therapy and rational antibiotic prescribing are outlined in National Antibiotic Guidelines (NAG). All healthcare facilities shall develop and document its local antimicrobial guideline based on antimicrobial surveillance results. The policy should be endorsed by the Drugs and Therapeutics Committee and ultimately the hospital director/District Health Officer and must be made available to all HCWs.

The policy shall include the following guiding principles:

- Written indications for antimicrobials prescription.
- Appropriate microbiology investigations prior to antimicrobial commencement.
- Prescribe antimicrobials as guided by the National Antibiotic Guidelines or local antibiotic guideline where applicable.
- Formulation of a list of restricted antimicrobials and the procedures for obtaining approval.
- That prescribers review the patient's clinical response while on antimicrobial therapy with a view to streamline therapy as more clinical information becomes available.

8.3.1.1 Development of antibiotic policy and guideline

Each healthcare facility shall establish a multidisciplinary team to develop an antimicrobial policy and guideline with members with the necessary expertise and experience (eg. Senior clinicians, Infectious Disease specialists, Physicians,



Surgeons, Paediatricians, Clinical Microbiologist, Pharmacist etc.). National policy and guideline may be reviewed and adapted to suit local circumstances, if deemed necessary. The scope for antimicrobial guidelines should include empirical use, treatment and prophylaxis for hospital acquired infections and community acquired infections.

8.3.2 Surgical Prophylaxis

8.3.2.1 Antibiotic surgical prophylaxis

The aim of surgical prophylaxis is to reduce rates of healthcare-associated surgical site infections in high risk/specialised procedures, hence reducing surgical morbidity and mortality.

General Principles

1. Consider individual risk factors for every patient – need for prophylaxis, drug choice or dosage alteration.
2. Optimal pre-operative dosing timing is usually within 60 minutes before surgical incision. However, some antimicrobials such as clindamycin, fluoroquinolones, gentamicin, metronidazole and vancomycin should be administered within 120 minutes before surgical incision.

Usually a single dose is sufficient. A second dose maybe required in the following situations:

- a) Delay in start of surgery.
- b) prolonged operations

The finding of pus or perforated viscous at surgery implies that infection was present before surgery and warrants a full course of treatment.

8.3.3 Monitoring and reviewing of antibiotic policy

Antimicrobial policy and guideline should be reviewed at periodic intervals and updated according to current evidence, clinical practice guidelines and local circumstances.

8.4 Antimicrobial Stewardship (AMS) Protocol

(Please refer to Protocol on Antimicrobial Stewardship Program in Healthcare Facilities)

9

SPECIFIC MICROORGANISM OF CLINICAL INTEREST

9.1 Multi-Drug Resistant Organism

9.1.1 Introduction

- Multi-drug resistant organisms (MDROs) are bacteria that have developed resistance to more than 2 different classes of antibiotics. Development of multi-drug resistance has been associated with inappropriate and overuse of antibiotics. For example, Vancomycin use leads to Vancomycin-resistant *Enterococci* (VRE), third generation Cephalosporin and Quinolone use leads to ESBL producers and MRSA and Carbapenems use leads to CRE.
- Resistant organisms of significance in healthcare settings include:
 - Gram negative organisms e.g. CRE, ESBL-producing bacteria, *Acinetobacter sp.* and *Pseudomonas aeruginosa*.
 - Gram positive organisms e.g. MRSA and VRE

9.1.2 Gram Negative MDRO

9.1.2.1 Carbapenem-resistant *Enterobacteriaceae* (CRE)

- CRE is a group of gram negative bacteria that are resistant to Carbapenem group of antibiotics. Common organisms include *Klebsiella pneumoniae*, *E. coli* and *Enterobacter spp.*
- The resistance occurs due to production of carbapenamase such as *Klebsiella pneumoniae* carbapenamase (KPC), New-Delhi Metallo-beta-lactamase (NDM) and Verona Integron-Mediated Metallo-beta-lactamase (VIM).

Note: Since 2015, Mobilized Colistin Resistance (*mcr-1*) gene was discovered among CRE in several parts of the world. It makes bacteria resistant to the antibiotic Colistin, which is used as a last-resort drug to treat patients with multi-drug-resistant infections.

9.1.2.2 ESBL- producing organisms

- ESBL producing organisms confer resistance to second and third generation Cephalosporins group. Common organisms include *Klebsiella pneumoniae*, *E. coli*, *Enterobacter spp* and *Proteus spp*.

9.1.2.3 *Acinetobacter spp.*

- *Acinetobacter spp.* is gram-negative bacteria, usually posing no risk to healthy people.
- They can live in the environment for several days.

9.1.2.4 *Pseudomonas aeruginosa*

- *Pseudomonas aeruginosa* is gram-negative bacteria usually implicated in HCAI.

Transmission of MDROs

The transmission of these organisms in hospital and community is by direct contact i.e. person to person spread via staff, patient or visitors through contaminated hands, equipment and surfaces.

9.1.3 Gram Positive MDRO

9.1.3.1 Introduction

Concerns about MRSA and VRE are related to their potential for transmission in healthcare as well as in community and the limited number of antibiotics available to treat infections caused by these organisms. According to National Antibiotic Resistance Surveillance Report 2017, **the prevalence rate of MRSA is 0.15% and VRE is 0.01% in 2016. (Refer IMR report)**

9.1.3.2 Methicillin-Resistant *Staphylococcus aureus*

- *Staphylococcus aureus* is facultative anaerobe, non-motile, catalase positive, gram-positive cocci which are predominantly arranged in grape-like clusters.
- *Staphylococcus aureus* that is resistant to the synthetic penicillin (methicillin, oxacillin, nafcillin) is referred to as MRSA.
- They colonize the skin, particularly the anterior nares, skin folds, hairline, axillae, perineum and umbilicus. They may also colonize chronic wounds,

for example in eczema, venous ulcers and decubitus ulcers.

- Screening for MRSA colonization can be performed by culture of the nares or wound swabs.

9.1.3.3 Transmission

- MRSA is transmitted primarily via direct contact between person-to-person, commonly through the hands of health care workers.
- Nasal carriage of MRSA is common.

9.1.4 Infection Control and Prevention

Prevention of Colonization and Infection

9.1.4.1 Special units

The Infection Prevention and Control Team in collaboration with the relevant clinical team, should be proactive in assessing the high risk patients and risk of transmission of MDROs especially in the high risk areas or units (e.g. ICU, Burns Unit, Oncology).

9.1.4.2 Antibiotic policies

1. Antibiotic usage should follow the NAG and local antibiotic guidelines with special reference to antibiogram pattern.
2. Avoid excessive use of broad-spectrum antimicrobials as a first-line treatment as it will encourage the emergence of MDROs.
3. Antimicrobial prophylaxis when indicated for surgery should be as narrow-spectrum as possible, given at appropriate time and restricted to one dose unless clinically indicated.

9.1.4.3 Disinfection of equipment and medical instruments

(Please refer to Chapter 13: Sterilization & Disinfection)

1. It is recommended that sterilization and disinfection for all equipment are done in Central Supply and Sterilization Service (CSSS).
2. Moist respiratory equipment such as ventilator tubing, nebulizers and humidifiers that come into direct contact with patients' mucosa are easily contaminated with gram-negative organisms which can lead to cross contamination.
3. It is therefore important that correct procedures for decontamination are followed and the equipment is thoroughly dried before use for next patients.



4. Heat disinfection should be used wherever possible for equipment used in the ward.
5. Disinfectors such as bedpan washers must be maintained and checked regularly to ensure that adequate temperatures are reached (normally 80°C for 1 min), and written records of maintenance must be kept.
6. Disinfection procedures in wards should, where necessary, be checked by the Infection Control Team.
7. All creams, gels and liquids used with such equipment must be stored in such a way as to prevent contamination and patient-to-patient spread of gram negative organisms. Single-use disposable sachets are preferred.

9.1.4.4 Contact based precaution.

1. All HCW must practice hand hygiene.
2. Gloves should be used whenever indicated. Regardless of gloving, hand hygiene should be practiced before and after patient contact.
3. Recommended attires
 - i. Bare below elbow
 - ii. Aprons are recommended to be worn when attending to patients.
 - iii. Gowns may be worn if splashing or extensive soiling is likely.
4. Contact based precaution should be strictly adhered to at all times, irrespective of patient placement.
5. Visitors shall obtain permission and instruction from the on-duty nurse before any contact with patients. They must practice hand hygiene according to its indications.

9.1.4.5 Ward practices

1. Avoid re-use of a previously opened ampoule of water or sodium chloride solution for injections.
2. Avoid the use of stock solutions for preparation of IV fluids.
3. Use sterile fluids for nebulizers and humidifiers to prevent contamination.
4. All shared communal facilities such as lavatories; bathrooms, etc. should be cleaned at least three times daily and are kept dry.
5. Terminal cleaning shall be performed upon patient discharge.
6. The taps and sinks should be designed to minimise splashing from the sink area.

9.1.4.6 Management

A. MRSA

Antibiotics are used for treatment of MRSA infections and for eradication of skin and nasopharyngeal colonization. Eradication of colonized patients is recommended for high risk patients who are scheduled for surgical procedures, ICU admissions, in outbreak situations and mentally-challenged patients.

1. Personal hygiene of colonised and infected patients
 - Bathe daily and wash hair twice weekly with an antiseptic body wash such as 4% chlorhexidine gluconate scrub or 2% triclosan for 5 days. May be repeated if indicated.
 - Use a disinfectant dusting powder (hexachlorophene 0.33%) after bathing and drying. Apply to axilla, groin and any skin folds.
2. Nasal carrier
 - The usual treatment for nasal carriage is mupirocin, which is an effective topical agent.
 - Apply mupirocin nasal ointment three times per day for a period of five days.
 - A 'matchstick-head' size of ointment should be applied to the inner side of the nostril.
 - After the five-day treatment course, stop eradication therapy for two days and repeat the swabs.
 - If after two courses of mupirocin treatment the nasal carriage is not eradicated, it is important that mupirocin is stopped because of the risk of resistance.
3. Wound treatment

Colonisation or infection caused by MRSA may delay wound healing. These general principles can be applied:

 - Clean wound with sterile water.
 - Use povidone-iodine or silver sulphadiazine preparations where possible.
 - Cover wound with an appropriate dressing.
 - **DO NOT USE TOPICAL ANTIBIOTICS FOR LOCALISED WOUND INFECTION**

B. VRE

1. Patients with VRE must be assessed before commencing treatment as colonization occurs more frequently than infection.
2. Attempts at clearance by oral antimicrobial therapy are usually unsuccessful and therefore not recommended.

9.1.4.7 Risk Categories for Acquiring MDROs

Risk categories			
High	Moderate	Low	Minimal
Intensive Care	General surgery	Geriatric (acute)	Geriatric (long stay)
Special care baby unit	Urology	General medicine	Psychiatric
Burns unit	Neonatal	Paediatric	Psychogeriatric
Transplant Unit	Gynaecology		
Cardiothoracic	Obstetric		
Orthopaedic	Dermatology		
Trauma			
Vascular			

9.1.5 Recommended Practices for MDROs Screening.

9.1.5.1 Screening

1. High risk areas in a hospital where MDROs are endemic:
 - Admission screening
 - Discharge screening for MDROs positive patient
 - Screening of contacts
2. Moderate, low and minimal risk areas for MDROs.
 - Screen all patients if there is evidence of contact
 - Admission screening is recommended for the following patients:
 - Previously infected / colonized.
 - History of frequent hospital admissions
 - Transferred from MDROs affected hospitals

Note: Routine screening of HCW is not recommended. Screening of HCW is ONLY indicated when an outbreak situation is uncontrolled.

9.1.5.2 CRE

1. Contact screening of CRE patients must be performed
2. Faeces/rectal swab is the most useful screening specimen.
3. Colonized patients may also be identified by screening at other sites e.g. urine.

9.1.5.3 Patient Screening for VRE

- Faeces/rectal swab is the most useful screening specimen.
- Colonized patients may also be identified by screening at other sites e.g. wounds and vascular catheter sites.

9.1.5.4 Environmental screening

Environmental screening should only be done during an outbreak
(Please refer to Chapter 12: Environmental)

9.1.6 Transfer of colonized / infected patient

Before the transfer, make prior arrangements with the receiving centre / ward / unit

1. Within the hospital
 - Bathe & wash hair with antiseptic detergent 4% chlorhexidine gluconate scrub or 2% triclosan
2. Out-patients or specialist clinics e.g. radiology department, wound dressing
 - Keep at the end of working session
 - Adhere to standard precaution at all times
 - Advisable to tag patient's appointment card
3. Another hospitals
 - Communication between the centres especially Infection Control Unit
4. Discharge of patients
 - Inform GP / health care staff
 - Home care advice to family members
 - Tag patient for future references
5. Deceased patients
 - Plastic body bags not necessary
 - Communicate with forensic unit personnel



9.1.6.1 Transport of colonized / infected patients

- Lesions should be covered WITH impermeable dressing.
- HCW should wear appropriate PPE.
- Transport trolley or wheelchair should be cleaned with disinfectant after use.
- Staff should practice hand hygiene always.

9.2 Viruses

9.2.1 Introduction

Based on the route of transmission, viral infections can be classified into four categories:

1. Gastrointestinal Infection;
2. Respiratory Tract Infection;
3. Exanthematous Disease (skin lesions, vesicles); and
4. Blood-borne Infection.

Type	Mode of Transmission	Source	Virus
Gastrointestinal Infection	faecal-oral	Faeces	<ul style="list-style-type: none">• Rotaviruses• astroviruses• enteroviruses• adenoviruses• coronaviruses
Respiratory Tract Infection	Droplets	Contaminated hands	<ul style="list-style-type: none">• influenza viruses• parainfluenza viruses• respiratory syncytial virus• adenoviruses• enteroviruses• rhinoviruses• human metapneumovirus and corona viruses

Exanthematous Disease.	<ul style="list-style-type: none"> • respiratory secretions • faeces • urine • skin lesions 		<ul style="list-style-type: none"> • enteroviruses • varicella-zoster virus (VZV) • measles • Human Parvo virus B19 • rubella virus.
Blood-borne Disease	<ul style="list-style-type: none"> • blood • body secretions 		<ul style="list-style-type: none"> • Hepatitis B • Hepatitis C • Human Immunodeficiency Virus • Congo Haemorrhagic Virus

9.2.2 Gastrointestinal Infection.

The above viruses that cause GIT infection may also present with other systemic manifestations e.g. respiratory tract infections.

- The route of transmission is predominantly faecal-oral, often via contaminated hands. Thus, infection control strategies should focus on contact with focally contaminated items and include gowns, gloves, and hand hygiene.
- Masks are only advised to be worn during close contacts or high-risk procedures and when taking care of vomiting patients.
- Most infections are mild, self-limiting, and do not require any specific therapy.

9.2.3 Respiratory Tract Infection.

- Route of transmission for respiratory viruses is mainly via droplets.
- Infection control measures should be aimed at aerosol transmission and direct contact and may include isolation, masks, gowns, gloves, and hand hygiene.
- During aerosol generating procedures, use of N95 respirator and eye protection-is recommended.

9.2.4 Exanthematous Disease.

Many viral infections can cause exanthema, vesicles, or other skin lesions.

- Less frequently occurring viruses that can cause nosocomial infections



include those causing haemorrhagic fevers such as arena viruses (Lassa, Machupo, Junin), and Filoviruses (Marburg and Ebola).

- These viruses require strict isolation because they are transmitted by blood and body fluids.

9.2.5 Blood borne Infection.

- Routes of transmission are blood and body fluids, including breast milk.
- The risk of infection after a needle stick is 5 to 40% for HBV, 1 to 10% for HCV, and < 0.5% for HIV.
- Standard precautions should be practiced when handling blood and body secretions in all patients and attention given to safe disposal of needles and sharps. (Please refer to Chapter 11: Occupational Health & Safety)

9.2.6 Vaccination

Vaccination is available for polioviruses, hepatitis A, hepatitis B, varicella, influenza, measles, mumps, rubella, and rabies.

9.3 Fungal Infections

9.3.1 Introduction

- The incidence of fungal infections has increased in recent years as the immunocompromised population increases.
- Risk factors for systemic fungal infections include neutropenia, long-term central venous catheter access, exposure to broad-spectrum antibiotics, all forms of vascular catheterization, mechanical ventilation, blood transfusions, haemodialysis, diabetes mellitus, steroid use, immunosuppression, parenteral feeding, and presence of urinary catheters
- Incidence of *Candida* bloodstream infection (BSI) is 17 cases per 1000 ICU admission and more than half (59.8%) were due to non-albicans *Candida* species.
- Hospital construction and renovation have been associated with an increased risk for nosocomial fungal infection, particularly aspergillosis.
- The non-pathogenic fungi such as *Trichosporon*, *Paeilomyces*, *Acromium* species, *Mucormycosis* agents and *Dematiaceous* are increasingly being identified as nosocomial pathogens.

9.3.2 *Candida* Infection

- *Candida* infections including candidemia can be transmitted via the hands of healthcare workers

- Candiduria is especially common in patients receiving prolonged urinary catheterization and broad spectrum antimicrobial agents. This may be a coloniser.
- Isolation of *Candida* from any sterile site should be considered a significant finding in an ICU patient. Heavy colonization puts patients at risk for infection and should be considered in the decision to treat.
- Susceptibility testing of candida isolates may be helpful in patient management.

9.3.3 *Aspergillus* infection

- *Aspergillus* spp. is ubiquitous, can be cultured from the hospital environment (unfiltered air, ventilation systems, dust dislodged during hospital construction, carpeting, food and ornamental plants).
- Route of acquisition includes inhalation of fungal conidia, ingestion of contaminated food, contamination of adhesive tape or gauze used with intravascular catheters and contamination of patient care items.
- Contaminated air or ventilation systems have been associated with outbreaks of nosocomial aspergillosis.

9.3.4 Infection Prevention and Control Precautions

- Proper containment shall be practiced during construction and renovation of hospital building (*Please refer to Chapter 10: Hospital Outbreak Management*).
- Catheter insertion (IVC and urinary) must be performed only when it is indicated
- Remove existing intravascular catheter in patient with candidemia or acute haematogenously disseminated candidiasis.
- Remove CBD in patient with candiduria if possible

9.3.5 Infection Control and Ventilation Requirements for Patients undergoing allogeneic haematopoietic stem cell transplant.

- Patients undergoing allogeneic haematopoietic stem cell transplant should remain in a Protective Environment (PE) room except for required procedures that cannot be performed in the room, and they should use respiratory protection such as an N95 respirator when leaving the PE.
- Protective Environment room must be equipped with ventilation system to maintain positive room air pressure (*Please refer to Chapter 4: Isolation Room*)
- Maintain airflow patterns and monitor these on a daily basis.



- Minimize exposures of severely immunocompromised patients to activities that might cause aerosolisation of fungal spores. Avoid carpeting in patient rooms or hallways, upholstered furniture and furnishings, and fresh or dried flowers or potted plants in PE rooms or areas. When vacuum cleaning is needed, the vacuum should preferably be equipped with HEPA filters.
- Horizontal surfaces should be wet-dusted daily with cloths moistened with MOH approved hospital disinfectant and detergent. Methods that stir up dust should be avoided.
- Engineering features should include central or point-of-use HEPA (99.97% efficiency) filters that can remove particles > 0.3 µm in diameter for air supply; well-sealed rooms; properly constructed windows, doors, and intake and exhaust ports; smooth ceilings free of fissures, open joints, and crevices; walls sealed above and below the ceiling.

9.3.6 Investigation for source of nosocomial fungal infections outbreaks.

(Please refer to Chapter 10: Hospital Outbreak Management)

- If no epidemiologic evidence exists of ongoing transmission of fungal disease, conduct an environmental assessment to find and eliminate the source
- Collect environmental samples from potential sources of airborne fungal spores, preferably by using a high-volume air sampler rather than settle plates
- If either an environmental source of airborne fungi or an engineering problem with filtration or pressure differentials is identified, promptly perform corrective measures to eliminate the source and route of entry
- If an environmental source of airborne fungi is not identified, review infection-control measures, including engineering controls, to identify potential areas for correction or improvement
- If possible, perform molecular sub-typing of *Aspergillus* spp. isolated from patients and the environment to compare their strain identities.

(Please refer Chapter 3 for transmission based precautions)

10

HOSPITAL OUTBREAK MANAGEMENT

10.1 Definitions

10.1.1 Healthcare Associated Infection Outbreaks are defined as an:

- Increase in the number of healthcare associated cases of disease among patients or staff over and above the expected number of cases*.
**The expected number of cases can be determined through ongoing disease surveillance. This involves systematic collection of numerator and denominator data using standardized case definitions and surveillance methods.*
- In certain newly emerging disease e.g Legionnaires infection or anthrax, will only require 1 single case.
- Two or more infections with the same organism in patients receiving the same procedure within a short period of time (e.g. invasive *Staphylococcal* infection in patients undergoing epidural or intraarticular injection) are also constituted as an outbreak.

Commonly detected outbreaks involved:

- MRSA
- MDRO (e.g Multi-resistant *Enterobacteriaceae* or *Pseudomonas aeruginosa* or *Acinetobacter baumannii*)
- Diarrhoeal pathogens (e.g. *Salmonella*, *Campylobacter*, Norovirus, *Clostridium difficile* enterocolitis)
- Respiratory pathogens (e.g. Influenza, RSV)

10.1.1 Steps in Outbreak Investigation and Management

A suspected outbreak may be identified by a healthcare worker, by laboratory personnel, or by state/territory health authorities conducting routine surveillance or investigating reports of illness and from reportable disease notifications. When an outbreak is detected, the healthcare facility's infection control management system should be notified and an outbreak control team formed relevant to the size and

seriousness of the outbreak and the healthcare facility involved. If the outbreak control team determines it constitutes a major outbreak, the state/territory public health unit shall be notified.

An outbreak is considered as major when:

- A large number of people, or multiple cohorts of people, are affected.
- The organism involved is unusually pathogenic. There is a potential for transmission to large numbers of people.

Examples of major outbreak: foodborne Salmonella in hospital, hospital acquired influenza outbreak

The responsibility for investigation and the extent of investigations will vary according to the type of outbreak and circumstances. It is important to investigate an outbreak immediately, as the availability and quality of microbiological evidence and epidemiological data diminishes rapidly with time between illness and investigation.

An outbreak management plan should be developed based on local policy and consultation between the infection control professionals, healthcare workers, facility managements and state/territory health authorities as appropriate.

The outbreak response may differ according to the nature of disease, the virulence of the organism and the vulnerability of the patients concerned, however the principles that underlie an outbreak investigation are similar: identification of the aetiological agent; the route(s) of transmission; exposure factors and the population at risk.

Steps	Suggested Approach	Responsibilities (Dependent on Facility and Type of Outbreak)
STEP 1: Recognise outbreak and prepare to investigate		
Determine existence of the outbreak	<ul style="list-style-type: none"> • Establish background rate of disease • Consider if observed number of cases is in excess of the usual number and cases are typical • Examine surveillance data 	<ul style="list-style-type: none"> • Infection Control Team

Determine if immediate control measures are needed	<ul style="list-style-type: none"> Reinforce standard precautions Apply appropriate transmission-based precautions 	<ul style="list-style-type: none"> Healthcare workers - as soon as outbreak is suspected
Notify and communicate	<ul style="list-style-type: none"> Inform Administrator i.e Hospital Director, Head of Department / Unit, Nurse Managers (Matron / Sister) Notification to Public health unit (if notifiable disease or required pursuant to public health legislation) 	<ul style="list-style-type: none"> Infection Control Team Medical Officer in charge / Nurse / Health Inspector
Formation of an Outbreak Management Team (OMT) – this will vary according to location/ resources; made up of one or more people with designated responsibility	<ol style="list-style-type: none"> Form an OMT: <ul style="list-style-type: none"> Membership may include but is not limited to: <ul style="list-style-type: none"> Administrators (Hospital Director and Chief Matron) Head of Department / Unit Infection control practitioners Clinical Microbiologist Clinician Others as defined by circumstances Call for a meeting Plan for investigations 	<ul style="list-style-type: none"> Infection Control Chairman

STEP 2: Verify the diagnosis and confirm that an outbreak exists

<p>Confirm the existing of outbreak that meet the above criteria</p> <p>Consider likely outbreak definition and whether criteria are met</p>	<ul style="list-style-type: none"> Confirm clinical diagnosis (symptoms and features of illness) Review laboratory data and request additional laboratory tests if necessary, e.g molecular typing of organisms to confirm clonality 	<ul style="list-style-type: none"> Clinicians Laboratory personnel Infection Control Team
--	--	--

	<ul style="list-style-type: none"> • Establish whether there are more cases than expected (refer Surveillance data) • Review scientific literatures 	
STEP 3: Establish case definition and find cases		
Establish a set of standard criteria to decide whether or not a person has the disease of concern	<p>Case definition should be based on:</p> <ul style="list-style-type: none"> • Clinical information about the disease • Characteristics of the people who are affected • Information about the location • Specification of time period for the outbreak • Mode of transmission • Case definition can be refined later after collection of primary data • Cases can be classified as 'Confirmed' (usually laboratory verification); 'Probable' (usually has typical clinical features); 'Suspect' (usually has fewer typical clinical features) 	<ul style="list-style-type: none"> • OMT
Find cases (mapping & line listing)	<ol style="list-style-type: none"> 1) Gather critical information by: <ul style="list-style-type: none"> • Interview • Retrieve disease notification 2) Search and control, both cases and carriers 3) Health alerts (to create awareness among the health staff for identification of cases with similar signs and symptoms) 	<ul style="list-style-type: none"> • OMT • Healthcare workers

Identify and count cases	Collect the following types of information: <ul style="list-style-type: none"> • Patient particulars • Demographic information • Clinical information • Risk factor information 	<ul style="list-style-type: none"> • OMT
Tabulate this information in a line list, that is updated as new cases appear	<ul style="list-style-type: none"> • Time: date of onset of illness • Person: age, sex • Place: where did the exposure occur? • Other relevant information 	<ul style="list-style-type: none"> • OMT
STEP 4: Characterise outbreak by person, place, and time		
Review descriptive epidemiology of all cases	<ul style="list-style-type: none"> • Person: sex, age, occupation, residence • Place: information that provides information on possible source of agent and nature of exposure • Time: date and time of onset; record relevant events in a timeline 	<ul style="list-style-type: none"> • OMT
Create epidemic curve to determine hypotheses	<ul style="list-style-type: none"> • Number of cases on y-axis • Time on x-axis 	<ul style="list-style-type: none"> • OMT
STEP 5: Determine who is at risk		
Identify groups at risk	<ul style="list-style-type: none"> • Number of ill people • Time and place of onset • Personal characteristics 	<ul style="list-style-type: none"> • OMT
Initiate precautionary measures	<ul style="list-style-type: none"> • Use of standard precautions and appropriate transmission-based precautions 	<ul style="list-style-type: none"> • Healthcare workers • Infection control practitioners

	<ul style="list-style-type: none"> • Increase frequency and efficiency of environmental cleaning using appropriate products • Prophylactic treatment (i.e. antibiotic / immunisation when indicated) • Antibiotic restrictions, use according to indications • Exclusion of cases from high risk activities • Conduct screening of patients and contacts; • Isolation and/or cohort of patients or contacts . • Restricting movement of patients, staff and visitors • Provision of health information and advice 	
STEP 6: Test hypothesis with established facts		
Perform epidemiologic study	<ul style="list-style-type: none"> • Cohort • Case-control 	<ul style="list-style-type: none"> • OMT
Analyse the data	<ul style="list-style-type: none"> • Compare risk factors among ill (cases) vs. not ill (controls) • Attack rates • Relative risk 	<ul style="list-style-type: none"> • OMT or • Outsourced to consultant with knowledge of statistical methods
STEP 7: Carry out further studies if necessary		
To support the hypothesis or if analytic studies do not confirm the hypothesis	<ul style="list-style-type: none"> • Further study to refine case definition • May involve testing of environmental samples, food samples or environmental screening in some situations (e.g. <i>Legionella</i>, <i>Pseudomonas</i>) 	<ul style="list-style-type: none"> • OMT

STEP 8: Implement ongoing control / prevention measures
(This can be done at any time during the outbreak as deemed necessary).

Review measures initiated for immediate control (Step 1 and Step 5)	<ul style="list-style-type: none"> To determine the adequacy of infection control measures in reducing the risk of transmission 	<ul style="list-style-type: none"> OMT Healthcare facility management
Implement appropriate ongoing control measures and strategies to prevent further transmission	<ul style="list-style-type: none"> Restrict spread from the case Interrupt chain of infection Reduce risk of acquiring the infection Assessment of policy, regulations, standards 	<ul style="list-style-type: none"> OMT Healthcare facility management
Communicate and coordinate with all stakeholders	<ul style="list-style-type: none"> Electronic flagging/tagging of medical records of contacts Reinforcement of infection control precautions to staff, patients and visitors 	<ul style="list-style-type: none"> Healthcare workers OMT Infection control practitioner

STEP 9: Communicate findings

Prepare written report that evaluates methods used for the control of the outbreak	<ul style="list-style-type: none"> Include discussion of factors leading to outbreak, comprehensive timelines, summary of investigation and documented actions Short and long term recommendations for prevention of similar outbreak Disseminate to appropriate stakeholders including publication 	<ul style="list-style-type: none"> OMT Healthcare facility management
--	--	---



10.1.2 Screening Measures

The Infection Control Team will decide on the screening strategies to be implemented. The strategies should take the following into account:

- Who to screen?*
- When to screen?
- How to screen?
- Where to screen?
- Which tests?

* Screening of healthcare workers is discouraged unless in circumstances where the healthcare workers are deemed to be colonisers or carriers of the infection e.g MRSA carriers.

10.1.3 Cleaning Process for Specific Microorganisms.

In all instances, clean in accordance with the prescribed method statement. To identify the level of cleaning required for specific microorganisms (*Please refer to Chapter 12: Environmental*)

10.1.4 Microbiologic Work-ups

- The laboratory personnel should be consulted on the type of samples and proper collection, storage and transportation of laboratory specimens.
- Environmental/disinfectant/solution samplings or swabs from instrument should be considered for collection if they are highly suspicious as the potential source of infection. This should be discussed with Infection Control Team.
- Molecular typing of the organisms is needed to establish if epidemiologically related isolates are genetically related (clonal-relatedness). This should be discussed with microbiologist.

10.1.5 Unknown Pathogen Outbreak

1. This is considered as emergency outbreak situation
 - Consider as WHO Risk Group IV pathogen which is highly infectious and may potentially lead to public health threat.

2. HCWs must adhere at all times (ED, clinic, wards, mortuary) :
 - Full PPE must be practiced at all times
 - Isolating cases based on all 3 modes of transmission until proven
 - Safe handling of clinical samples
 - Clinical samples must be processed immediately and result made available as soon as possible
 - Follow strictly guidelines on infection control practice when transporting patient
3. Laboratory result must be traced as soon as possible
4. All cases must be notified immediately to Infection Control Doctor/ Hospital Director/ MOH when cases are suspected

The Flow Chart of Event-based Surveillance in Hospitals

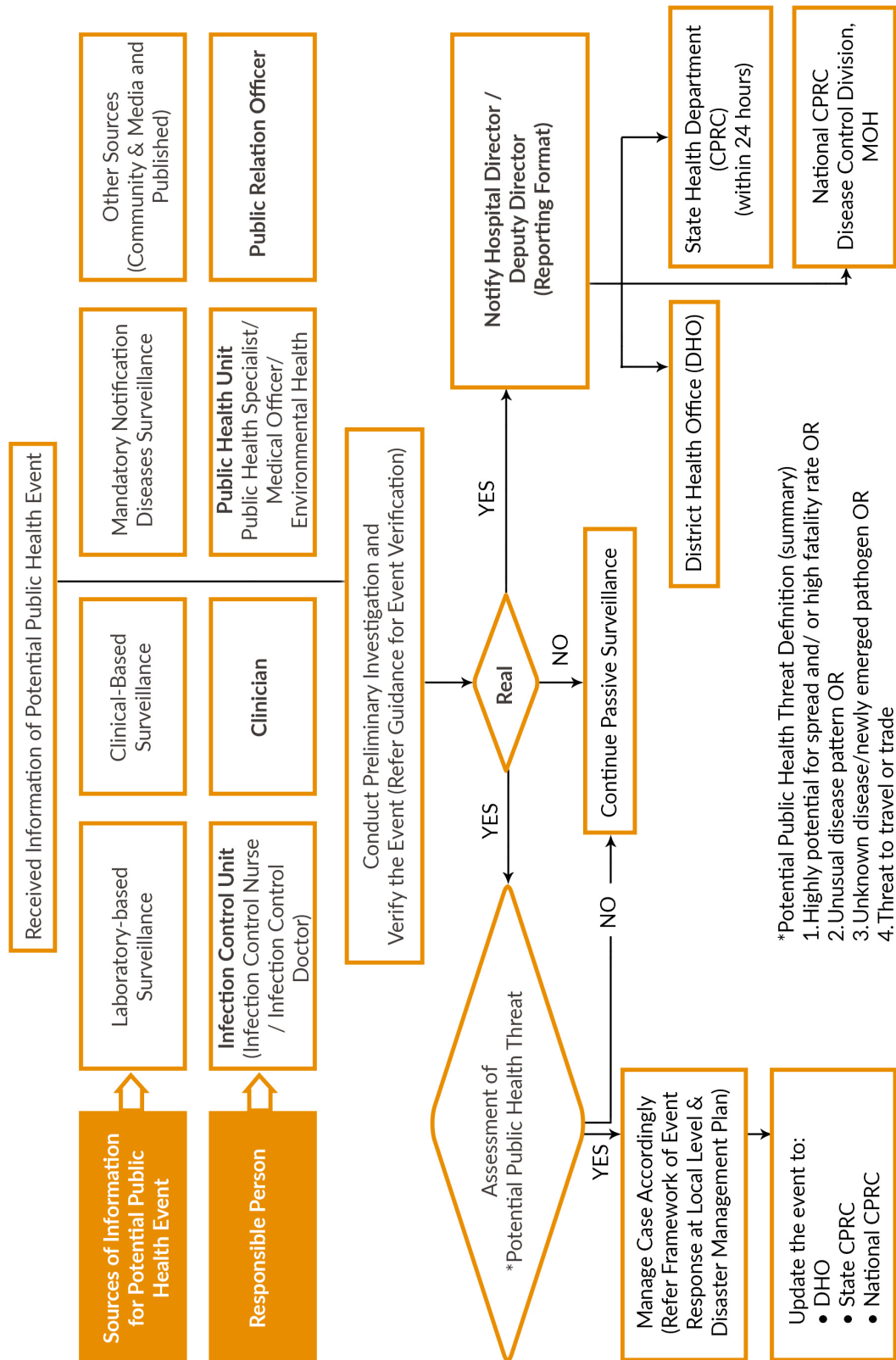

11

OCCUPATIONAL SAFETY AND HEALTH FOR HEALTHCARE WORKERS

11.1 Introduction

The Ministry of Health, Malaysia aims to create awareness and reduce the risk on exposure to microbiological hazards at healthcare setting via sharps injury, mucosal exposure and other healthcare associated infection. Thus, disseminating information throughout the hospital regarding the prevention and immediate management of sharps incidents and other HCAI must be carried out by Infectious disease physician and Occupational Health Physician.

All new HCWs must attend an infection control briefing, while regular training sessions should be plan for all HCWs which includes:

- The risk associated with blood and body-fluid exposure.
- The correct use and disposal of sharps

11.2 Definitions

11.2.1 Sharps

- includes all sharps instruments/devices used in healthcare facilities (e.g. all types of needles, scalpel, trochar, broken glass, lancet and other sharps devices.

11.2.2 Blood borne pathogens

- are infectious microorganisms in human blood that can cause disease in humans. These pathogens include, but are not limited to, Hepatitis B (HBV), Hepatitis C (HCV) and Human Immunodeficiency Virus (HIV).

11.2.3 Healthcare associated infection

- refers to infection acquired from healthcare facilities via contact, droplets or airborne transmission..

11.3 Healthcare Workers Screening and Post Exposure Prophylaxis for Blood Borne Pathogens (BPP)

Generally, the BPP screening is recommended at pre-employment and post exposure after a sharps or splash injury.

11.3.1 Pre-employment Screening for BPP

Pre-employment screening (cover HIV, HBV and HCV infections) will assist to identify healthcare workers (HCW) who are vulnerable and provide adequate protection if uninfected such as providing Hepatitis B vaccination. The identified HCW would be managed and counselled. Deployment is only done if necessary.

When is pre-employment screening for BBP recommended?

- i. Newly employed MOH.
- ii. Existing HCWs who are moving to a different position or going for further training that involve exposure prone procedures.

11.3.2 Post Exposure of Blood Borne Pathogens Management

i. Post exposure screening and clinical management

Evaluation and clinical management of HCWs who sustains sharp injury need to be conducted immediately along with confidential counselling and follow up. Exposure assessment of sharp injury or mucosal splash will determine further clinical management of vaccination and provision of post- exposure prophylaxis (PEP). Baseline blood investigation and management follow as outlined in table 1 and table 2 below.

Table 1: Management of exposure to blood borne pathogens of affected HCW

Blood borne Pathogen	Blood test	Clinical Management
1. HIV	Anti-HIV Elisa	<ul style="list-style-type: none">• Antiretroviral agents for PEP• Modify work practices involving EPP

2. HBV	HBsAg Anti-HBs	<ul style="list-style-type: none"> • Previously vaccinated with poor response/non-responder <ul style="list-style-type: none"> - Single dose of Hep B Immunoglobulin 0.06 ml/kg IM within 24 hours - Hepatitis B vaccine series. • Previously vaccinated with adequate response (Anti-HBs \geq 10 mIU/mL) • No therapy needed • Modify work practices involving EPP
3. HCV	Anti-HCV (if positive, proceed with HCV RNA)	<ul style="list-style-type: none"> • No prophylaxis • Modify work practices involving EPP

*If HCW found to infected with either one of the above, treatment will be provided.

Table 2: Responsibility and roles in managing HCWs expose to blood borne pathogens

Responsible Person	Roles
<p>Attending doctor will be responsible for assessing the risk (using OHU/SIS-2a form)</p>	<p>1. Assessment of source patient</p> <ul style="list-style-type: none"> • Ascertaining the HIV, HBV and HCV status of the source including history of risk behavior • If the status of source patient is unknown, baseline testing should be done and obtaining informed consent (see the above table)
	<p>2. Assessment of injury</p> <ul style="list-style-type: none"> • Evaluating the potential of HIV, HBV and HCV transmission based on body substance involve, the route and severity of injury • Treating the physical injury/ cut

	<p>3. Assessment of the exposed HCW</p> <ul style="list-style-type: none"> • Provide counselling • Assessing Hepatitis B immunisation status • Collet blood test (HIV, HBV and HCV) • Commencing PEP when indicated. • Referring case to relevant physician
Physician	<ul style="list-style-type: none"> • Providing clinical management of HCWs who develop seroconversion • Provide counselling of affected employee
Occupational & Enviromental Health Physician	<ul style="list-style-type: none"> • Ensuring the timely and appropriate management of sharps in accordance with “Sharps Injury Surveillance Manual 2007” • Notification within 1 week to State Occupational and Environmental Health Unit • Using OHU/SIS-1 for investigating case within 1 week using OHU/BS-01 <ul style="list-style-type: none"> - Assessing workplace - Identify hazards and contributing factors - Suggesting control measures and ensuring those measures being done

ii. Post Exposure Follow Up

Follow up is determined during baseline risk assessment of disease transmission. If indicated, courses of follow up is planned at 6 weeks, 3 months and 6 months post exposure to assess clinically and reviewing of blood serological test.

Table 3: Emergency Sharps Information

All HCWs Please Note:

If you experience a sharps injury or were exposed to the blood or other body fluid of a patient during the course of your work, **immediately follow these steps:**

- Wash needle sticks injury and cuts with soap and water
- Flush splashes to the nose, mouth, or skin with water
- Irrigate eyes with clean water, saline, or sterile irrigants
- Report the incident to your supervisor
- Immediately seek medical treatment

All sharp injury or blood/ blood product splash must be notify using OHU/SIS-1 form and investigate by Occupational Safety and Health Committee.

11.4. Healthcare Workers Screening for Tuberculosis (TB)

A. Screening

TB Screening for HCW to be performed as follows :

- i) Pre placement for newly appointed HCW
- ii) Periodic screening for in service HCW
- iii) Pre-retirement/ Pre transfer for staffs working in high risk area that is going to retire and transfer out.

(Please refer to Tatacara Pelaksanaan Proses Saringan Tibi bagi anggota Kementerian Kesihatan- Pekeliling Ketua Pengarah Kesihatan Bil 9/2012)

B. Control Measure for TB Prevention in Healthcare facilities

The control measures are based on a three – level hierarchy of controls which are:

1. Environmental controls
2. Administrative controls (managerial)
3. Personal protective equipment

Diagram 1. – Prevention of TB Infection Among HCWs

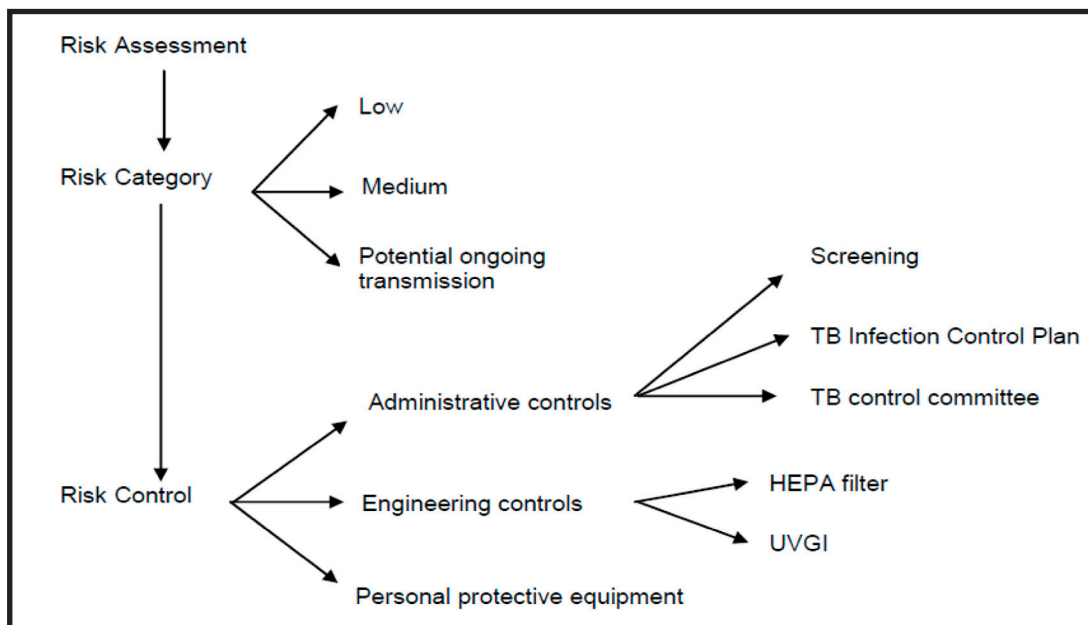

ENVIRONMENTAL CONTROL MEASURES AT HEALTH CARE FACILITIES

Certain areas of the health care facility can be considered as high risk and priority should be given in implementing environmental controls.

Table 5: High risk areas at health facilities:

• Isolation rooms	• Operating Rooms
• Medical wards and clinic	• Emergency Department
• Intensive Care Unit	• Micro-laboratory
• Bronchoscopy Suites	• Radiology Department
• Outpatient clinic	• Healthcare clinic

A variety of simple to complex EC can be used to reduce the number of aerosolized infectious droplet nuclei in the work environment:

- Maximizing natural ventilation through open windows

- Control source of infection by using local exhaust ventilation and diluting and removing contaminated air by using general ventilation
- More complex and costly methods involve the use of mechanical ventilation i.e. local exhaust ventilation (LEV) and negative pressure rooms which may remove infectious particles and the use of ultraviolet germicidal irradiation (UVGI) to sterilize the air. All rooms should have an airflow of preferably ≥ 12 air exchanges per hour (ACH). Directional air flow should be maintained from clean air intake area, across the HCW, across the patient, and filtered before exhausted outside

Diagram 2. An enclosing booth designed to sweep air past a patient with tuberculosis disease and collect the infectious droplet nuclei on a high efficiency particulate air (HEPA) filter

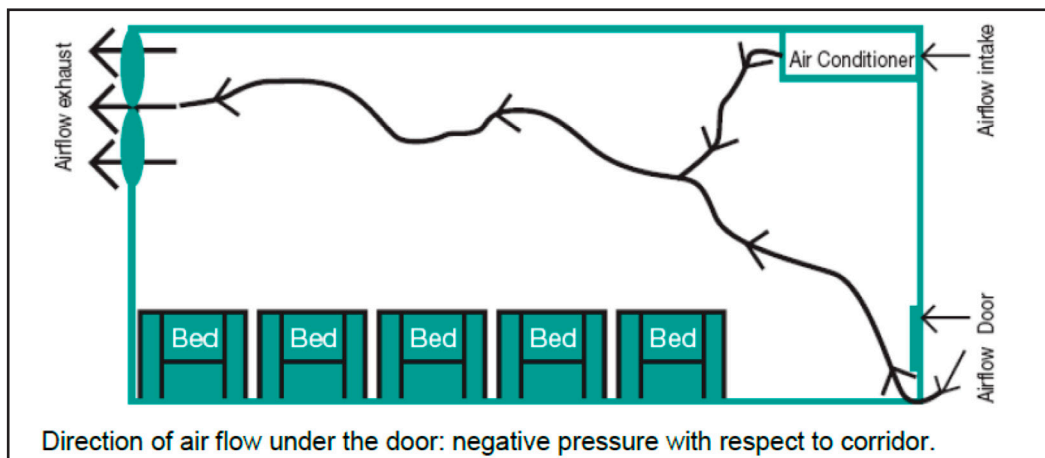
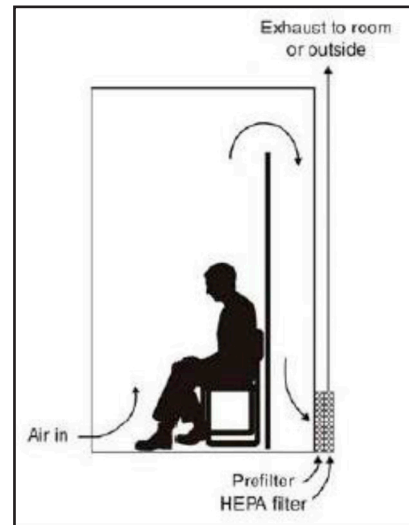

Diagram 3. Negative pressure rooms; diagram illustrating airflow from outside a room, across patients' beds and exhausted out the far side of the room

Source: *Guidelines for Preventing the Transmission of Mycobacterium Tuberculosis In Health-Care Settings, 2005. MMWR Recommendations and Report. CDC, 30th December 2005 / 54(RR17)*

C. Sterilize the air by using 'ultraviolet germicidal irradiation' (UVGI).

UVGI uses effective dose of ultraviolet-C (UV-C) radiation at 253.7 nanometers (nm) to kill or inactivate microorganisms so that they are no longer able to replicate and form colonies. UVGI is more useful in a high risk area; that which fulfills the specific requirements of its use. Should not be used in place of HEPA filters when discharging air from isolation booths directly into the surrounding room.

ADMINISTRATIVE CONTROL

The administrative controls are important measures to reduce the risk of exposure of HCWs and patients to M. Tuberculosis. Administrative controls consist of the following activities:

i. TB Control Program in Healthcare Facilities:

- It is highly recommended to establish a team in hospital with high TB cases among HCW. This team should be coordinated by Public Health Unit.
- Train the persons responsible for implementing and enforcing the TB Infection Control Program.
- Designate one person with a back-up as the TB resource person to whom questions and problems should be addressed.

ii. TB Infection Control Plan:

Establish a written TB Infection Control Plan. This protocol should include: -

1. Measures to control TB transmission
 - a. Rapid identification, isolation, diagnostic evaluation and prompt treatment of patients likely to have TB.
 - b. Comprehensive case and contact investigation and notification.
 - c. Follow Safe Operating Procedure for infectious diseases, including transport/transfer of patients with fast tract or to be called as last case for procedure.
 - d. Environmental control measures and their maintenance .
 - e. Provide adequate PPE -N95 mask for HCW, surgical mask for confirmed and suspected case of TB.

- f. Training, educating and counselling HCWs.
- g. Periodic evaluation of the program.

PPE FOR HCW:

Use of appropriate PPE for HCW: Please refer to chapter 3

11.5 Immunisation for Healthcare Workers

Health care workers are the main workforce in the hospitals. Outbreak of infectious diseases among them may contribute to the disruption of the services. Infected HCW could be the source of disease transmission to patients. Thus, vaccination of HCW against vaccine-preventable diseases highly recommended. The main aims are:

- To ensure protection against vaccine-preventable diseases
- To prevent sickness absence related to vaccine-preventable diseases
- To protect patients especially those who are highly susceptible.

Current Policy and Practices

The vaccines recommended for HCW are Hepatitis B, Influenza, Measles, Mumps, Rubella, Tetanus, Diphtheria, Pertussis, Varicella and Typhoid. The vaccination programme for HCW in MOH are Hepatitis B, influenza and Typhoid (for food handlers). Post vaccination serologic testing for Hepatitis B antibodies is required to assess the efficacy of the vaccine. MMR (Measles, mumps and rubella) vaccine and Tdap (Tetanus, Diphtheria and Pertussis) vaccine are preferred for newly employed HCW who do not have documented vaccination.

At the same time, the infection prevention control measures must be strengthened and remain the most important strategy to prevent transmission of disease in all health facilities.

The following vaccines are **not routinely recommended** for HCWs unless necessary:- BCG vaccine, Hepatitis A vaccine , Meningococcal polysaccharide vaccine ,Vaccinia , Anthrax vaccine and Rabies vaccine

11.6 Diphtheria and Meningococcal Chemoprophylaxis for Healthcare Workers

Infection	Indication	Antibiotic Dosage
Exposure to Diphtheria case	Exposure risk: aerosolised procedures or intubation without mask.	IM Benzathine Penicillin G 1.2 M units OR Oral Erythromycin 500 mg 6 Hourly for 7-10 days
Exposure to Meningococcal case	Exposure risk: aerosolised procedures or intubation without mask	Oral Ciprofloxacin 500 mg OR Oral Azithromycin 500 mg single dose OR Oral Rifampicin 600 mg 12 Hourly for 2 days

11.7 Monitoring

The Occupational Health / Infection Control Unit will generate incident statistics relating to sharps injury, immunization registry, tuberculosis screening status, training, and investigate trends or specific incidents as appropriate.

From the data obtained, recommendations for improvement can be provided to the management in the respective facilities.

12

ENVIRONMENTAL

12.1 INFECTION CONTROL DURING CONSTRUCTION & RENOVATION

12.1.1 General information

Construction and renovation activities in the hospital may be associated with transmission of pathogens such as filamentous fungi, including *Aspergillus* spp. *Candida* spp, *Fusarium* and also bacteria such as *Legionella* and *Nocardia*. The most commonly reported hospital construction-related infection is *Aspergillus*, which represent the greatest threat to neutropenic patients.

The construction activities include new construction projects and major demolition of buildings. These activities create a lot of dust which may carry fungal spores. Moderate levels of dust may be associated with activities such as sanding of walls prior to painting, construction of new walls and major cabling activities. Inspection and noninvasive activities such as removal of ceiling board for visual inspection, painting and minor plumbing works are low risk activities that generally cause minor generation of dusts.

The documentation of project shall include the mechanism and scope for infection control protocols and practice during construction and renovation activities in health facilities. For specific containment measures, please refer to Facility Engineering Management Services Project Operational Guidelines (POG), which is available at the engineering unit of the hospital.

12.1.2 Preliminary consideration

The three major topics to consider before initiating any construction or repair activity are as follows:

- a. Design and function of the new structure or area,
- b. Assessment of environmental risks for airborne disease and opportunities for prevention, and
- c. Measures to contain dust and moisture during construction or repairs.

Pre-construction and renovation consultation should be carried out in advance between all the stakeholders, including hospital management, infection control unit, microbiology unit, security unit, project architects and engineers and the contractor. This will help to identify the scope and nature of work and also to assess the degree of risks and potential patient groups that may be affected.

Procedures to contain or minimize dispersal of dust are necessary during construction activities. Examples include physical partitioning, rerouting of human traffic away from work areas, wet mopping and door mat placement at entrance, prompt debris removal, blocking and sealing of air vents where appropriate, and use of negative pressure at the construction sites.

12.1.3 Infection Control Risk Assessment (ICRA)

An infection-control risk assessment (ICRA) conducted before initiating repairs, demolition, construction, or renovation activities can identify potential exposures of susceptible patients to dust and moisture and determine the need for dust and moisture containment measures. The risk assessment consists of the following 3 steps;

- I. Identify the type of construction project activity
- II. Identify the patient risk groups
- III. Match the construction activity type with the patient risk group on the Construction Class Matrix to establish the construction class.

This assessment focuses on the type and extent of the construction or repairs in the work area.

It is recommended that regular inspection be done to ensure that infection prevention and control measures are in place during and after construction phase.

12.1.4 Environmental sampling

There are currently NO recommendations for routine environmental culturing during construction.

Air sampling is ONLY recommended for

- Commissioning of new operating rooms.
- Post renovation of operating rooms
- Outbreak investigation if the source is likely to originate from operating rooms

Note: air sampling is not recommended after change of HEPA filter

12.1.5 Hand-over and Pre-Occupation Stage

It is the hospital's responsibility to ensure that the area complies with hospital cleanliness standards for occupation after construction completed. The hospital should thoroughly clean and decontaminate all surfaces including walls, ceilings, and windows as well as high-risk area ventilation systems, service cavities and ceiling spaces.

Infection Control Risk Assessment

Matrix of Precautions for Construction & Renovation

Step One: Identify the Type of Construction Project Activity

TYPE A	<p>Inspection and non-invasive activities.</p> <p>Includes, but is not limited to:</p> <ul style="list-style-type: none">• removal of ceiling tiles for visual inspection only, e.g., limited to 1 tile per 50 square feet• painting (but not sanding)• wall covering, electrical trim work, minor plumbing, and activities which do not generate dust or require cutting of walls or access to ceilings other than for visual inspection.
TYPE B	<p>Small scale, short duration activities which create minimal dust</p> <p>Includes, but is not limited to:</p> <ul style="list-style-type: none">• installation of telephone and computer cabling• access to chase spaces• cutting of walls or ceiling where dust migration can be controlled.
TYPE C	<p>Work that generates a moderate to high level of dust or requires demolition or removal of any fixed building components or assemblies</p> <p>Includes, but is not limited to:</p> <ul style="list-style-type: none">• sanding of walls for painting or wall covering• removal of floor coverings, ceiling tiles and casework• new wall construction• minor duct work or electrical work above ceilings• major cabling activities• any activity which cannot be completed within a single workshift.

TYPE D	<p>Major demolition and construction projects</p> <p>Includes, but is not limited to:</p> <ul style="list-style-type: none"> • activities which require consecutive work shifts • requires heavy demolition or removal of a complete cabling system • new construction.
---------------	---

Step Two: Identify the Patient Risk Groups

If more than one risk group will be affected, select the higher risk group:

Low Risk	Medium Risk	High Risk	Highest Risk
<ul style="list-style-type: none"> • Office areas 	<ul style="list-style-type: none"> • Cardiology • Echocardiography • Endoscopy • Nuclear Medicine • Physical Therapy • Radiology/MRI • Respiratory Therapy 	<ul style="list-style-type: none"> • CCU • Emergency Room • Labor & Delivery • Laboratories (specimen) • Newborn Nursery • Outpatient Surgery • Pediatrics • Pharmacy • Post Anesthesia Care Unit • Surgical Units 	<ul style="list-style-type: none"> • Any area caring for immunocompromised patients • Burn Unit • Cardiac Cath Lab • Central Sterile Supply • Intensive Care Units • Medical Unit • Negative pressure isolation rooms • Oncology • Operating rooms including C-section rooms

Step Three: Match the construction activity type with the patient risk group on the Construction Class Matrix to establish the construction class.

Construction Class Matrix
Construction Project Type

Patient Risk Group	TYPE A	TYPE B	TYPE C	TYPE D
LOW Risk	I	II	II	III/IV
MEDIUM Risk	I	II	III	IV
HIGH Risk	I	II	III/IV	IV
HIGHEST Risk	II	III/IV	III/IV	IV

Note: Infection Control approval will be required when the Construction Activity and Risk Level indicate that **Class III** or **Class IV** control procedures are necessary.

Description of Required Infection Control Precautions by Class

	During Construction Project	Upon Completion of Project
CLASS I	<ol style="list-style-type: none"> 1. Execute work by methods to minimize raising dust from construction operations. 2. Immediately replace a ceiling tile displaced for visual inspection 	<ol style="list-style-type: none"> 1. Clean work area upon completion of task.
CLASS II	<ol style="list-style-type: none"> 1. Provide active means to prevent airborne dust from dispersing into atmosphere. 2. Water mist work surfaces to control dust while cutting. 3. Seal unused doors with duct tape. 4. Block off and seal air vents. 5. Place dust mat at entrance and exit of work area 6. Remove or isolate HVAC system in areas where work is being performed. 	<ol style="list-style-type: none"> 1. Wipe work surfaces with disinfectant. 2. Contain construction waste before transport in tightly covered containers. 3. Wet mop and/or vacuum preferably with HEPA filtered vacuums before leaving work area. 4. Upon completion, restore HVAC system where work was performed
CLASS III	<ol style="list-style-type: none"> 1. Remove or Isolate HVAC system in area where work is being done to prevent contamination of duct system. 2. Complete all critical barriers, to seal area from non work area before construction begins. 	<ol style="list-style-type: none"> 1. Do not remove barriers from work area until completed project is inspected by Hospital authorized personnel. 2. Remove barrier materials carefully to minimize spreading of dirt and debris associated with construction.



CLASS III	<ol style="list-style-type: none"> 3. Contain construction waste before transport in tightly covered containers. 4. Cover transport receptacles or carts. Tape covering unless solid lid. 	<ol style="list-style-type: none"> 3. Vacuum work area preferably with HEPA filtered vacuums 4. Wet mop area with disinfectant. 5. Upon completion, restore HVAC system where work was performed.
CLASS IV	<ol style="list-style-type: none"> 1. Isolate HVAC system in area where work is being done to prevent contamination of duct system. 2. Complete all critical barriers and seal area from non-work area before construction begins. 3. Seal holes, pipes, conduits, and punctures. 4. An alternative route must be planned so that all personnel involved in construction / renovation not to pass through the critical area. In situation where this is not possible, construct an anteroom and require all personnel to pass through this room so they can wear coveralls that are removed each time they leave work site. 5. Do not remove barriers from work area until completed project is inspected by the hospital's authorized personnel. 	<ol style="list-style-type: none"> 1. Remove barrier material carefully to minimize spreading of dirt and debris associated with construction. 2. Contain construction waste before transport in tightly covered containers. 3. Cover transport receptacles or carts. Tape covering unless solid lid 4. Vacuum work area preferably with HEPA filtered vacuums. 5. Wet mop area with disinfectant. 6. Upon completion, restore HVAC system where work was performed.

12.2 OPERATION THEATRE COMMISSIONING

12.2.1 Introduction

Most surgical site infections are endogenous in origin. Exogenous sources of infections are controlled with the application of appropriate practices and a controlled ventilation system. Sources of infection include:

- The patient
- The operating room staff, from skin scales, expired air, hair, sweats etc.
- The surgical instruments
- Clothing worn by operating room staff;
- The room and equipment used in the room;
- Air supplied to the room;

The function of operating theater ventilation system is to prevent airborne microbial contaminants from entering surgical wounds. Under normal circumstances, source of airborne microbial contaminants are skin scales released by HCWs working in the theater. A proportion of these skin scales are contaminated with the normal skin flora (20 % are *Staphylococcus aureus*). The rate of dispersion is increased with movements and number of individuals present in the theater.

The commissioning test of a new or recently renovated operating theatre should include:

1. **Air quality**– air exchange rate, ventilation system, air particle count
2. **Workmanship**– joint sealing, gaps around doors
3. **System**– temperature, humidity, pressure

Recommended specification for operating theatre

Types of Operating theatre	Humidity	Air sampling (cfu/m ³)	Room air changes	Flow rate m/s	Temperature (°C)
Conventional	50 - 60 %	< 10	15 -25 ACH	0.65-0.75	18 - 22
Ultraclean	50 - 60 %	< 1	> 25	0.2	16 - 21

Microbiological air sampling of operating theatres should also be done either as part of an investigation into theatre-acquired infection

12.2.2 Planning for Infection Control Commissioning / Re-commissioning

1. Received written request/form to perform commissioning from authorized personnel
2. The following conditions have been met:
 - All new and refurbished work have been completed
 - All engineering commissioning procedures have been completed
 - Full clean of all surfaces must be completed 3 times using disinfectant (approved by KKM) with sufficient time for surface to dry in between each cleaning.
 - Full clean of equipment surfaces using disinfectant (approved by equipment manufacturer) at least once.
 - Ventilation system has been running continuously for 24 hours
 - The OT must not be used during this time and no one are allowed to come in during the sampling processes.
3. Establish information on OT conditions from engineering department or external maintenance company (existing) or contractor (new/refurbished) regarding the particulars below:
 - Temperatures in the OT and related adjacent rooms i.e. (scrub room, anesthetic room, preparation room, disposal room and corridor)
 - Humidity in OT room
 - Pressure differentials between the rooms
 - Air changes within each OT
4. Inform the OT Sister when the commissioning is to take place.

12.2.3 Air Sampling procedure

12.2.3.1 Preparation

- Get the advice of Clinical Microbiologist/ Science officer prior to commissioning.
- Perform air particle count. If the level is above normal range, proceed to air sampling.
- Prepare the air sampler before the procedure
 - Fully charged the battery
 - Get the sieve cap autoclaved a day before the process
 - Order the required number of culture plates required for sampling process (nutrient / blood agar)
- Change into clean OT attire

- Prepare the sampling materials outside the OT. Clean the surface of a trolley with alcohol swabs, place a sterile wrapping paper. Place the sterile sieve cap, sterile gloves and alcohol swabs on a sterile gallipot on the trolley.
- Set the timing of the Air sampler to 10 minutes to sample optimally a volume of 1,000 liters of air. A shorter time will be allowed but the number of colonies isolated will be multiplied by a constant factor (follow manufacturer's instructions). The sample volume should not be less than 250 liters of air and not more than 1,000 liters as it will cause the agar to dry off.

12.2.3.2 Sampling method

- The number of samples taken depends on consensus of the ICCT. A single sample collected from each OT would be adequate if all the OT parameters are within normal range and there are no obvious defects seen.
- Only one staff shall set up the air sampler in the OT to minimize dispersion contamination.
- The air sampler should be placed in the middle of the OT table or secured on a trolley where the theater table is usually located and approximately 1 m above floor level .
- Using aseptic technique, place the culture plate into the air sampler.
- Once the air sampler has been set, the staff should leave the OT and close the door.
- Allow a few minutes gap to clear the air and using a remote or extension wire, start the air sampler. It should sample 1m³ (10000 L) of air.
- All doors must be closed and keep the theater empty until sampling is completed.
- Once the air sampler has stopped, remove the plate and carefully place the cap, label the plate. (OT name/number, date, volume of air if not standardized)
- Once completed immediately send all the plates in a closed carrier container to the Microbiology laboratory.

12.2.3.3 Microbiology

- Check the plates label and the request form together with the ICN who perform the sampling.
- Incubate the plates at 37 °C for nutrient agar and place the blood agar in the CO₂ incubator with temperature at 37 °C.
- Inspect the plates after 24 hours and count the colonies grown on each plate, note on the work sheet.



12.2.3.4 Results and Interpretation

- Reporting: _____ Colony forming unit (CFU) /m³
- Interpretation of results: Aerobic cultures on non-selective medium should not exceed 35 cfu/m³ ventilating air.
- Fungal cultures may be indicated in some circumstances where fungal contamination were suspected. They are not done routinely for OT commissioning
- Agar used will be Sabouraud plus chloramphenicol and gentamicin
- Fungal cultures should not exceed **35cfu/m³** ventilating air

12.2.4 Air Flow

The operating theatre should be independent of the general traffic and air movement in the rest of the hospital. Proper ventilation, humidity (<60%), and temperature control in the operating room is important for the comfort of surgical personnel and patients, also in preventing environmental conditions that encourage growth and transmission of microorganisms.

1. The direction of air flow between rooms in a theater suite is used to ensure that there is no backflow of air from either dirty rooms or from contaminated areas in the hospital.
2. The ICN should carry out smoke testing
 - To observe for turbulent airflow particularly around the position of the OT table
 - Any backflow from the OT to adjacent rooms (anesthetic room, scrub room, disposal room, corridor)
 - For Smoke testing method, refer to chapter 4 : isolation room
3. Particle count
 - Charge the battery of the counter before the commissioning takes place
 - Check whether it is functioning.
 - Select the differential count size on the menu
 - Place the counter on the OT table and press start
 - Take the reading once the reading stops.
 - The reading should be very minimum under the air curtain.
 - Measure at the center and at each of the 4 quadrants.
4. Report on completion of the commissioning
 - Contents
 - Description of the OT room, reasons for testing, general nature of tests performed
 - Summary of test results and observations

- Conclusions and recommendations
- Tabulated results with interpretations

Examples of air sampling report

Test Performed	Result	Comment
1. Inspection of control and warning devices within the OT	In good condition	Complies
2. Bacterial count	12 cfu/m ³	Complies
3. Leakage around or through HEPA filter (detection by means of Electronic Particle Counter)	No evidence of leak	Complies
4. Smoke tests	<ol style="list-style-type: none"> 1. There is a good airflow in all 4 quadrants 2. There is no areas of gross turbulence observed 3. There is a clear movement of air from the OT table towards the periphery and out through the outlet fins and from the inside the OT room to the outside room 	Complies

Interpretation of result : _____

Conclusions : _____

Recommendation: : _____



12.3 ENVIRONMENTAL CLEANING

12.3.1 General Consideration

The environment in healthcare facilities should be kept dry, clean, well ventilated, and ideally exposed to sunlight to prevent microbial multiplication and the spread of MDRO pathogens. Reducing bacterial contamination in the environment reduces the risk for acquiring HCAI. Thus, environmental cleaning is a fundamental principle of infection prevention in healthcare settings. (ref 1)

The frequency of cleaning and disinfecting individual items or surfaces in a particular area or department depends on:

- a) Whether surfaces are high-touch or soiled area
- b) The type of activity taking place in the area
- c) The vulnerability of patients housed in the area; and
- d) The probability of contamination

12.3.2 Routine cleaning

General Clean: is a measure of cleanliness based on visual appearance that includes dust and dirt removal, waste disposal and cleaning of windows and surfaces. It is the basic cleaning that takes place in **ALL** areas of a health care setting.

Hospital Clean is a measure of cleanliness routinely maintained in care areas of the health care setting. Hospital Clean is 'Hotel Clean' with the addition of disinfection, increased frequency of cleaning, auditing and other infection control measures in client/patient/resident care areas.

Education and training of both managers and staff undertaking environmental cleaning should be clearly defined in written policies and evaluated regularly using checklists during inspection.

A. General Cleaning Practices for All Health Care Settings

1. Before Cleaning:

- Follow precautions signs and remove clutter before cleaning.
- Follow the manufacturer's instructions for proper dilution and contact time for cleaning and disinfecting solutions
- Gather materials required for cleaning before entering the room
- Clean hand before enter the room

2. During Cleaning:

- Progress from the least soiled areas (low-touch) to the most soiled areas (high-touch) and from high surfaces to low surfaces
- Remove gross soil prior to cleaning and disinfection
- Wet/damp mop prior to dry mop
- Water for mop washing shall be replaced whenever the colour of water become darker or cloudy.
- Never shake mops and no '*double-dipping*' of cloths
- Change cleaning solutions as per manufacturer's instructions; more frequently in heavily contaminated areas; when visibly soiled; and immediately after cleaning blood and body fluid spills
- Containers for liquid soap, cleaners/disinfectants are disposable and do not practise '*topping up*' since it can result in contamination.
- Collect waste, handle plastic bags from the top (do not compress bags with hands)
- Clean hands on leaving the room

3. After Cleaning:

- Tools used for cleaning and disinfecting must be cleaned and dried between uses
- Launder mop heads daily; all washed mop heads must be dried thoroughly before reuse
- Clean housekeeping cart and carts used to transport waste daily

B. Cleaning Methods

When a patient is discharged, the room must be cleaned and disinfected thoroughly before the next patient comes in. Bathrooms should be cleaned last after completing cleaning of the room.

- Routine cleaning of housekeeping surfaces such (as floor) with detergents is sufficient in most circumstances. In case of outbreaks, especially when due to resistant microorganisms known to harbour in the environment, additional cleaning with a disinfection solution may be indicated
- Non-critical equipment in health care settings should only be cleaned with water and detergent or a low-level disinfectant. For electronic equipment, manufacturer's cleaning and maintenance instructions must be followed.

- Products used for cleaning and disinfecting in NICUs must not be toxic to infants (e.g. phenolics must not be used).
- In operating rooms, environmental cleaning must be performed with a regular documented cleaning schedule.
- Each haemodialysis station must be treated as an individual entity. After each haemodialysis, sufficient time between patients must be allocated for adequate cleaning.

12.3.3 Cleaning and Disinfection Practices for Patients on Additional Precautions/Terminal Cleaning

In addition to routine cleaning, additional cleaning practices and/or the use of personal protective equipment for cleaning may be required in health care settings under special circumstances.

A terminal clean is defined as “a procedure required to ensure that an area has been cleaned/decontaminated following discharge/transfer of a patient with an infection (i.e. MDROs or communicable disease) in order to ensure a safe environment for the next patient.

- Before entering the room, cleaning equipment should be assembled before applying PPE.
- PPE must be removed, placed in an appropriate receptacle and hands cleaned before moving to another room or task.
- PPE must not be worn or taken outside the patient room or bed space.
- Protocols for cleaning must include cleaning of portable carts or built-in holders for equipment.
- The room should be decontaminated from the highest to the lowest point and from the least contaminated to the most contaminated.
- Remove curtains and placed in red linen bag with alginate plastic after patient is discharged
- Use disinfectants such as sodium hypochlorite. The surface being decontaminated must be free from organic soil. A neutral detergent solution should be used to clean the environment prior to disinfection or a combined detergent /disinfectant may be used.

12.3.3.1 Cleaning Rooms on Contact Precautions

Cleaning patient rooms when an individual is on Contact Precautions requires the addition of PPE, as noted on the sign outside the room, as well as some extra procedures for patients/residents with VRE, *C. difficile* or norovirus.

All environmental service staff entering a room on Contact Precautions must put on a gown and gloves on entering the room, and must remove them and perform hand hygiene on leaving the room. Sufficient time must be allowed for cleaning and disinfection of rooms of patients/residents on Contact Precautions, particularly for *C. difficile* or norovirus.

A. Contact Precautions - *Clostridium difficile*

Strict adherence to hand hygiene that include hand washing.

C.difficile spores are only killed by sporicidal agents. The following sporicides have shown activity against *C. difficile* spores:

- **Sodium hypochlorite (1000 parts per million - ppm)**
- Accelerated hydrogen peroxide (4.5%)
- Peracetic acid (1.6%)

B. Contact Precautions – Norovirus

Cleaning regimens for norovirus should include:

- Prompt cleaning of emesis and faeces, including items in the immediate vicinity, followed by disinfection with an appropriate virucidal disinfectant;
- Increased frequency of bathroom and toilet cleaning and disinfection on affected units;
- Steam cleaning carpet and soft furnishings following regular cleaning, provided they are heat tolerant and at least 60°C is achieved.
- Strict adherence to hand hygiene.

12.3.3.2 Cleaning Rooms on Droplet Precautions

A. Routine Cleaning

Routine cleaning is being carried out according to general cleaning practice described in 12.3.2.A



Because some microorganisms transmitted by the droplet route survive in the environment, attention should be paid to high-touch items in the room as well as all items within the immediate vicinity of the client/patient/resident.

B. Terminal Cleaning

The terminal cleaning practices specified in 12.3.3 shall be used for rooms on Droplet Precautions.

12.3.3.3 Cleaning Rooms on Airborne Precautions

Housekeeping staff entering a room on Airborne Precautions for tuberculosis must wear a fit-tested and seal checked N95 respirator. The door must be kept closed to maintain negative pressure, even if the client/patient/resident is not in the room.

A. Routine Cleaning

Routine cleaning as described in 12.3.2.A shall be used for rooms on Airborne Precautions.

B. Terminal Cleaning

The terminal cleaning practices specified in 12.3.3 shall be used for rooms on Airborne Precautions. The following additional measures must be taken:

- After patient/resident transfer or discharge, the door must be kept closed and the Airborne Precautions sign must remain on the door until sufficient time has elapsed to allow removal of airborne microorganisms. Duration depends on ACH. With ACH of 12 or 15, the recommended duration is 23 to 35 minutes and 18 to 28 minutes with 99%-99.9% efficiency respectively.
- It is preferable to wait for sufficient air changes to clear the air before cleaning the room;
- If the room is urgently needed before the air has been sufficiently cleared of tubercle bacilli, an N95 respirator must be worn during cleaning
- Remove N95 respirator only after leaving room and door has been closed.

12.3.4 Basins for Handwashing

- Handwash basin is required in each treatment room. The basin should be sited close to where clinical procedures are carried out.
- Features:
 - Large enough and with curved sides to contain and reduce splashes.
 - Taps should enable the user to turn them off without contaminating hands i.e. elbow operated or sensor. Avoid swan neck-tap as they do not empty fully after use.
 - **Spray taps are not recommended (H&S Legionella)**
 - The tap outflow should not point directly into the basin outlet to avoid splashing and avoid overflows.
 - Basins should be sealed to the wall and allow effective cleaning.
 - Walls behind basin and around taps should be protected with a waterproof material to prevent damage and allow easy cleaning.
 - Hand decontamination agents should be wall mounted at an appropriate height near the sink.
 - Liquid dispensers must not be refillable but capable of taking disposable cartridges.
 - Paper towels should be available for hand drying. Re-usable towels or hot air dryers are not acceptable in a healthcare environment.
 - A separate foot operated waste bin must be sited by each basin. Open waste bins are not acceptable.

Note:

- i. *The hand washbasins in clinical patient rooms as a source of multidrugresistant Gram-negative bacteria especially Acinetobacter spp., Pseudomonas aeruginosa, and others is recently been highlighted.*
- ii. *Products used for cleaning and decontamination of the environment should be used according to the hospital policy, manufacturer's instructions, and available scientific information.*

12.3.5 Terminal cleaning/Decontamination of ambulance

Routine cleaning/terminal cleaning of an ambulance should follow routine cleaning procedures described in 12.3.2.A and types of additional precaution applied to the patient being transferred. Guidelines on MERS-CoV Management in Malaysia, September 2015 (annex 5b) can be used as a reference.

DISINFECTION AND STERILIZATION

13

13.1 General Principles and Policies

Infection prevention and control require the use of sterile medical equipment for aseptic procedures in hospital. Reusable medical equipment must be reprocessed before it can be re-used. Reprocessing critical and semi-critical single-use medical equipment is not encouraged.

Safe reprocessing of medical equipment is very important to ensure sterility to:

- a. prevent transmission of microorganisms to personnel and clients/patients and
- b. minimizing damage to medical equipment/devices from foreign material (e.g., blood, body fluids, saline and medications) or inappropriate handling.

There must be a centralized area for reprocessing medical equipment/devices.

Reprocessing performed outside the centralized area must be kept to a minimum. It must be approved by the Infection Control Committee or those accountable for safe reprocessing practices and must conform to the requirements for reprocessing space. In smaller settings, such as clinics or offices in the community, this refers to any segregated area where reprocessing of equipment/devices takes place, away from clients/patients and clean areas.

The central processing area(s) ideally should be divided into at least three areas: decontamination, packaging, as well as sterilization and storage. Physical barriers should separate the decontamination area from the other sections to contain contamination on used items. There must be a regular schedule for environmental cleaning in the Central Sterilization and Supply Unit (CSSU). The design parameters and requirement are as below in Table 13.1:

Table 13.1: Design parameters adapted (ANSI/ASHRAE/ASHE standard 170-2008)

Location	Minimum outdoor ACH	Minimum total ACH	All room air exhausted directly to outdoors	Air recirculated by means of room unit	Relative humidity (%)	Temperature (°C)
Decontamination room	2	6	Yes	No	No requirement	22-24 °C
Clean workroom	2	4	No requirement	No	Maximum 60	22-24 °C
Sterile storage	2	4	No requirement	No	Maximum 60	22-24 °C
Sterilizer equipment room	No requirement	10	Yes	No requirement	No requirement	No requirement

3.1.1 Policies and Safe Practices

The designated trained personnel should follow the written procedures and guidelines for sterilisation. There must be ongoing training and education at regular intervals on the reprocessing practices for all staff. All aspects of reprocessing procedures must be supervised.

- i. Hand hygiene facilities should be located at all personnel support areas and at all entrances and exits of the decontamination area.
- ii. Eating/drinking, storage of food, smoking, application of cosmetics in the reprocessing area is prohibited.
- iii. All staff working in reprocessing shall be offered Hepatitis B immunization unless they have documented immunity to Hepatitis B.
- iv. Appropriate personal protective equipment (PPE) should be worn for all reprocessing activities. PPE worn for cleaning and handling of contaminated equipment/devices includes gloves appropriate to the task, face protection (full face shield OR fluid impervious face mask and protective eyewear) and impermeable gown or waterproof apron.
- v. All protocols for environmental safety and reprocessing medical equipment/devices should be compliant with the local Occupational Health and Safety Act. Whenever chemical disinfection/sterilization is performed, air quality must be monitored when using products that produce toxic vapours and mists.

- vi. All new pressurized vessel and sterilizers shall have the DOSH fitness certificate and duly tested by them prior to use.

13.1.2 Transportation and Handling of Contaminated Medical Items / Equipment

Soiled medical items/equipment must be handled in a manner that reduces the risk of exposure and/or injury to personnel and clients/patients or contamination of environment:

- a. closed carts or covered containers designed to prevent the spillage, with easily cleanable surfaces, should be used for handling and transporting soiled medical items/equipment
- b. soiled items/equipment shall be transported by direct routes to areas where cleaning will be done, that avoids high-traffic, clean area and client/patient care areas
- c. containers or carts used to transport soiled medical items/equipment should be cleaned after each use
- d. disposal of sharps should be in a puncture-resistant sharps container at point-of-use, prior to transportation. *(Please refer to Chapter 3 on standard precaution)*

13.1.3 Disinfection of Reusable Medical items/equipment

Disinfection is the inactivation of disease-producing microorganisms. Disinfection does not destroy bacterial spores or prions. Disinfection of medical items/equipment falls into two major categories:

- high-level disinfection and
- low-level disinfection

(Please refer to Disinfection Manual 2018)

Reusable medical equipment/devices must be thoroughly cleaned before disinfection or sterilization to physically remove contaminants from the items/equipment. The process for cleaning would include pre-cleaning (disassembly, sorting, soaking), cleaning, rinsing, drying, physical inspection, lubrication and wrapping.

Key points to consider in the process of cleaning includes:

- Gross soiling (faeces, sputum, blood) should be removed immediately at point of use.
- If cleaning cannot be done immediately, the medical items/equipment must be submerged in water and detergent or enzymatic cleaner to prevent organic matter from drying on it.

- Any brushing if required should be done under water.
- Avoid cleaning the items/equipment under running water to minimize aerosolization of microorganisms.

Steps for Cleaning Process:

- i. Soaking
 - Do not use saline or corrosive disinfectants as a soaking solution as it damages some medical items/equipment
 - avoid prolonged soaking (e.g., overnight) of items/equipment.
- ii. Cleaning
 - can be done manually or using mechanical cleaning machines (e.g., washer-disinfector, ultrasonic washer, washer-sterilizer) after gross soil has been removed.
- iii. Rinsing
 - is necessary after cleaning, as residual detergent may neutralize the disinfectant.
 - The final rinse for items/equipment should be with treated water (reverse osmosis/distilled water). The process involves at least 2 rinses with treated water and the rinse solutions must be changed after each process.
- iv. Drying
 - is an important step that prevents dilution of chemical disinfectants which may render them ineffective and prevents microbial growth.
 - Manufacturer's instructions for drying of the items/equipment must be followed and items/equipment may be air-dried or dried by hand with a clean, lint-free towel.

Following the cleaning process, items/equipment must be reassembled, inspected, lubricated according to manufacturer's guidelines and wrapped prior to sterilization.

Audits of the cleaning process must be done regularly.

13.1.4 Reprocessing Endoscopy Equipment/Devices

Endoscopes can be divided into two types:

- a) Critical Endoscope:

Endoscopes used in the examination of critical spaces, such as joints and sterile cavities. Many of these endoscopes are rigid with no lumen. Examples of critical endoscopes are arthroscopes and laparoscopes. Critical endoscopes shall be **sterilized** prior to use.

b) Semi-critical Endoscope:

Fibreoptic or video endoscopes used in the examination of the hollow viscera. These endoscopes generally invade only semi-critical spaces, although some of their components might enter tissues or other critical spaces. Examples of semi-critical endoscopes are laryngoscopes, nasopharyngeal endoscopes, transoesophageal probes, colonoscopes, gastroscopes, duodenoscopes, sigmoidoscopes and enteroscopes. Semi-critical endoscopes require a minimum of **high-level disinfection** prior to use. Disposable items should be discarded immediately after use.

The area used to reprocess endoscopes must include:

- dedicated processing room(s) or area for cleaning and decontaminating instruments that are physically separated from clean areas, client/patient care areas and procedure rooms;
- utility sink(s) appropriate to the volume of work and method of decontamination must be available within processing/decontamination rooms or area;
- dedicated hand hygiene sink(s)
- space and utility connections for automatic endoscope reprocessor(s) (AER), if used;
- air-exchange equipment (ventilation system, exhaust hoods) should be used to remove toxic vapours generated or emitted from cleaning or disinfecting agent
- the vapour concentration of the chemical disinfectant used shall not exceed allowable limits (e.g., 0.05 ppm for glutaraldehyde);
- in-use disinfectant solutions must be maintained in closed, covered, labelled containers;
- Each health care setting in which endoscopic procedures are performed should have written detailed procedures for the cleaning and handling of endoscopes.

Endoscope reprocessing can be divided into six separate stages: precleaning, leak testing, cleaning, high-level disinfection, rinsing and drying.

I. Precleaning

Immediately following completion of the endoscopy procedure:

- flush and wipe the endoscope at point-of-use
- use an enzymatic cleaning solution
- place the endoscope and accessories in a covered, leak proof container and transport to the designated decontamination area.

II. Leak test

Leak test should be done after each use prior to cleaning. Leak testing should be performed according to the manufacturer's instructions before submerging the scope into reprocessing solution to minimize damage to scope parts.

III. Cleaning and Rinsing

- soak and manually clean all immersible endoscope components with tap/treated water and a recommended cleaning agent prior to automated or further manual disinfection or sterilization;
- disconnect and disassemble endoscope components (e.g., air/water and suction valves) as far as possible and completely immerse the endoscope and components in enzymatic cleaner;
- flush and brush all channels and lumens of the endoscope while it's submerged to remove debris and minimize aerosols;
- ensure that brushes used for cleaning lumens are of an appropriate size, inspected before and after use, and discarded or cleaned, high-level disinfected and dried following use.
- consider irrigation adaptors or manifolds that may be recommended by the manufacturer to facilitate cleaning;
- thoroughly rinse endoscope and all components with clean treated/filtered water prior to disinfection/sterilization and remove excess rinse water;
- identify damaged endoscopes and immediately remove from service;
- discard enzymatic cleaner after use according to manufacturer guideline.

Endoscope Disinfection

The following steps must be included in the disinfection procedure:

- Choice of disinfectant should be compatible with the endoscope and does not pass the expiry date;
- monitor the efficacy of the disinfectant before each use with test strips available from the product manufacturer;
- maintain a written log of monitoring test results;
- carefully follow the manufacturer's directions regarding the ambient temperature and duration of contact for the disinfectant (e.g., 2% glutaraldehyde for 20 minutes at 20°C);
- completely immerse the endoscope and its components in the high-level disinfectant/sterilant and ensure all channels are perfused;

- following disinfection, rinse the endoscope and flush the channels with treated water.
- Monitoring and auditing of high-level disinfection should be done by using chemical test strips to determine the effective concentration of active ingredients. Frequency of testing depends on the frequency of usage (test daily if used daily). Test strips must not be considered a way of extending the use of a disinfectant solution beyond the expiration date.
- Disposable sheaths/condoms placed over the endoscope reduce the numbers of microorganisms on the scope but do not eliminate the need for cleaning/disinfection/sterilization between uses.

IV. Drying and Storage of Endoscopes

Steps in the final drying of semi-critical endoscopes include:

- initial flushing of all channels with medical or filtered air;
- flushing all channels with 70% isopropyl alcohol to aid in the drying process
- second flushing of the channels with medical or filtered air.

Storage procedures:

- remove caps, valves and other detachable components during storage and reassemble just before use;
- store semi-critical endoscopes by hanging vertically in a well-ventilated area in a manner that minimizes contamination or damage; do not allow endoscopes to coil, touch the floor or bottom of the cabinet while handling, or be stored in their cases;
- ensure that endoscope storage cabinet is close to the endoscope to minimize contamination and are constructed of non-porous material that can be cleaned;
- clean and disinfected endoscope storage cabinets at least weekly.

Accessories

Endoscopic accessories (e.g., biopsy forceps and brushes) that break the mucosal barrier must be sterilized after each use, because of the difficulty in cleaning biopsy forceps/brushes, it is strongly recommended that disposable items be used.

Automated Endoscope Reprocessor (AER)

To achieve consistency in endoscope reprocessing, it is recommended that automated endoscope reprocessor (AER) be used. The end user must follow the manufacturer's instructions for use of the AER.

Equipment Used for Cleaning

The water bottle and its connecting tube, used for cleaning the endoscope lens and irrigation during the procedure, should receive high-level disinfection or sterilization at least daily. Sterile water shall be used to fill the water bottle.

Record-keeping

An accurate, permanent record of endoscope usage and reprocessing will assist in tracking endoscopes and clients/patients/residents in the event of a recall or follow-up. Retain records according to the policy of the facility.

Sterilization of Reusable Medical Equipment

Sterilization is the elimination of all disease-producing microorganisms, including spores (e.g. *Clostridium* and *Bacillus* species) and prions. The preferred method for sterilization of heat-resistant equipment is steam. (pre-vacuum sterilisers are preferred). The preferred sterilization method for heat sensitive instruments would be low temperature sterilization.

Methods of Sterilization

Selection of the agent used to achieve sterility depends primarily on the nature of the item to be sterilized. Sterilization process is either physical or chemical.

- 1) Thermal (physical)
 - Steam under pressure/moist heat (Steam sterilizer /autoclave is one of the most common form of sterilization)
 - Hot air/dry heat: Rarely used in CSSU
- 2) Chemical/cold sterilizers
 - Chemical sterilization is used for instruments and other items that are heat-sensitive or when methods that require heat are unavailable.
 - Ethylene oxide gas – its use should be discouraged.
 - Hydrogen peroxide plasma/ vapor/ low Temperature Gas Plasma Sterilizers- It is used to sterilize metal and non-metal surgical devices at low temperatures in a dry environment.

Monitoring the Sterilization Cycle

Monitoring the sterilization cycle is done to verify that the sterilization process is done accordingly. Routine monitoring of sterilizers involves the assessment of physical parameters of the sterilizer cycle, chemical indicators and biological indicators.

1. Physical Monitors

A physical monitor is a device that monitors the physical parameters of a sterilizer, such as time, temperature and pressure that are measured during the sterilization cycle and recorded (as a printout or electronic record) on completion of each cycle.

2. Biological Indicators (BI)

A biological indicator is a test system containing viable microorganisms (e.g., spore-laden strips or vials) providing a defined resistance to a specified sterilization process. The BI is generally contained inside a process challenge device (PCD) that simulates the in-use challenges presented by packaged devices. Once sterilized, a BI is incubated to see if the microorganism will grow, which indicates a failure of the sterilizer. Most BIs require up to 48 hours of incubation before the test is complete. Recently, however, rapid readout BIs have become available that provide results in one hour. Studies have shown that the sensitivity of rapid-readout tests for steam sterilization (1 hour for 132°C gravity sterilizers, 3 hours for 121°C gravity and 132°C vacuum sterilizers) parallels that of the conventional sterilization-specific BIs.

3. Chemical Indicators (CI)

A chemical indicator is a system that responds to a change in one or more predefined process variables with a chemical or physical change. There are six classes of chemical indicators which should follow the 'International Classes of Steam Chemical Indicators'. (*The ANSI/AAMI/ISO 11140-1:2005*)

Unacceptable methods of disinfection/sterilization include flash sterilization, boiling, ultraviolet irradiation, glass bead sterilization, chemi-clave and microwave oven sterilization.

Sterile Storage in the ward

Sterility maintenance is directly affected by packaging materials, handling, storage methods and condition. Sterile storage should only be used to store sterile items.

- Sterile items/equipment should be stored and handled in a manner that maintain the integrity of packs and prevent contamination from any source.
- The storage area shall be clean and free of dust, insects and vermin.
- Storage bins, carts and shelves should not be overloaded
- All items/equipment should be stored above floor level by at least 25 cm and from ceiling fixtures by at least 44 cm, 5 cm from the wall and protected by direct sun light.
- Temperature within the storage area should range from 22°C - 24°C with relative humidity from 50% - 60% (should not be near moisture source eg. sinks).
- The sterile items should be arranged according to the size (big sets singly, and small set not more than 3 stacks)
- 'First in, first out' (FIFO) is the principle to follow in the removal and replacement of sterile items in sterile storage.
- The shelf life of a packaged sterile item is event-related (no expiry date).
 - Physical damage – holes/tears
 - Moisture damage – wet package
- Routine checking of storage area is necessary on a regular basis and documented.

Note: Hand hygiene should be performed before accessing clean/sterile supplies. Do not use gloves.

COMMUNICATION AND SHARING

14

14.1 Introduction

Effective prevention and control of healthcare associated infection (HCAI) must be embedded into everyday practice and applied consistently. As with any risk assessment process, prompt identification, proper recording, appropriate action and effective monitoring are important to ensure high standards of infection prevention practices are in place.

Sharing of this essential information regarding a patient infection status when transferring them from one organization/unit to another ensures that any risks to the patient and others may be minimized.

Aims

1. To adequately assess the risk of a patient acquiring or transmitting an infection.
2. To share essential information about the infective status of a patient (either confirmed or suspected) when he/ she is transferred within the facility to other clinical areas. (other wards/ ICU/ outpatient clinics/ Radiology)
3. To share essential information about the infective status of a patient (either confirmed or suspected) with other health care/ community care providers when the patient is *Admitted to, Discharged from or Transferred between* hospitals and other health care facilities/ long term care facilities (eg nursing homes, welfare homes).

KEY PRINCIPLES

- A) **Patients with a known or suspected communicable/ transmissible infection (eg infections with droplets precautions/ multidrug resistant bacteria/PTB) should not be moved unnecessarily**, however sometimes it can't be avoided and patients have to shift beds, change wards or referred to other hospitals during their admission due to the following reasons:

1. Need for isolation
 2. Essential radiological based procedures/ Surgical procedures
 3. Change in clinical condition or specialty
 4. Transfer to an external health and/or community care provider
- B) Identifying patients at risk
Manually (eg colored stickers in the appointment cards/ case sheets) / Electronically tag patients who have been colonized / infected with MDR organism and incorporate this information into standard discharge process. *Patients who are contacts to CRE cases please refer to CRE case management policy and procedures*
- C) Standard Precautions are to be incorporated into everyday care of the patient. In addition to Standard Precaution each patients care should include practice of appropriate transmission based precautions.
- D) Clearly displaying Appropriate Precaution Signage (Contact/ Airborne/ Droplet) outside the room/cohort area in order to guide healthcare personnel to wear the appropriate PPE.
- E) Infection Control personnel or Staff in charge should inform clinical staff on the receiving end via written forms or via phone calls to update them on the proper precautions that need to be taken. *Designating a bedside nurse on a patient care unit as an infection control liaison or “link nurse” is reported to be an effective adjunct to enhance infection control at the unit level.*
- F) Organize regular training programmes and assess training needs for the staff in terms of appropriate infection control practices

INTERNAL TRANSFERS.

(Between Wards/ Outpatient clinics)

General principles

1. Assess the need to move the patient – if an inter-ward transfer can be postponed until the patient is no longer infectious (Table 1), without compromising the patients care and management in any way, then it should be delayed.
2. Patients with MDRO infections / colonization should not be moved unnecessarily even during bed shortages, unless for the purpose of cohorting or for acute care monitoring such as ICU.
3. Communication between wards/departments regarding the ‘infectious status’ of a patient is essential via phone call to the healthcare personnel in charge (Staff in charge and specialist/ consultant in charge) and enables the receiving ward/department to put its local procedures in place.

Health Care Worker Requirements

1. The staff should at all times adhere to Standard Precaution practice when in contact with the patient (before , during and after transfer)
2. The staffs who are involved in transporting and receiving the patient should at all times adhere to Standard Precaution practice and Appropriate PPE should be worn according to the risk of transmission as outlined in section *Fundamental Principles of Infection Prevention ; section B.* when in contact with the patient (before , during and after transfer)

Patient Requirements

1. It is recommended not to move patients unnecessarily however in cases where it can't be avoided patients are recommended to be transported via wheelchair/transportation trolley or beds (in case patient is deconditioned) in order to minimize transmission.
2. In patients with open wound or active drainage it is compulsory to use impervious dressings to cover the affected area(s).
3. Patients on Droplet / Airborne Precautions should wear a surgical mask and follow Respiratory Hygiene /Cough Etiquette in order to minimize the dispersal of droplet nuclei during transportation.

Terminal Cleaning

(Please refer to Chapter 12)

Disease	Period of infectivity
Pulmonary Tuberculosis (smear Positive)	<ol style="list-style-type: none">1. In general patients with active tuberculosis infection should be placed in an appropriate isolation ward with natural ventilation and open windows.(refer to isolation room chapter)2. In case patient is isolated in a room due to lack of natural ventilation in the health care facility, the patient can be de isolated if fullfils all of the following<ul style="list-style-type: none">• No suspicion of MDR TB• 2 weeks of effective antituberculosis treatment• Good clinical response to antituberculosis treatment

	<p><i>(If patient is being transferred to a ward with natural ventilation, they should be placed nearest to an open window. It is not necessary to wait for a negative sputum. It is recommended to wait for at least one negative AFB smear in case of transferring to a ward that lacks natural ventilation.)</i></p> <p>3. Patients with known / suspected multi-drug resistant TB (MDR-TB), isolate in a single room with negative pressure or adequate natural ventilation until smear negative.</p>
Measles	Airborne transmission precautions are indicated for 4 days after the onset of rash in immunocompetent patient / the whole duration of illness in immunocompromised individuals
Varicella Zoster (Chicken Pox)	<p>Patients are considered not infectious approximately 5 days after crusting of the rashes and if no more new rashes appear. (the period of infectivity dates back 48hrs before the onset of rash)</p> <p>In an immune-compromised patient the period of infectivity may be longer</p>
Rotavirus	Viral shedding is maximal when they are sick and can last up to 3 days after recovery. (max 10 days has been reported)
Clostridium deficile	<p>Contact Precautions and placement in private room/ cohorts with other confirmed Cdiff patients should be continued until patient is discharged if possible.</p> <p><i>Hand hygiene with soap and water is recommended for elimination of Clostridium difficile spores.</i></p> <p><i>The use of alcohol based rubs are not recommended.</i></p>

Diphtheria	Isolate all confirmed cases until 2 consecutive cultures are taken after completion of antibiotics
Salmonella typhi	Isolate all confirmed cases until 2 negative rectal swabs or stool culture

INTERNAL TRANSFERS

(Procedure Related transfers eg Operation theatre, Hemodialysis units, Interventional radiology)

General principles

1. Patients with active Contact/ Airborne and Droplet Precaution risks should be strongly encouraged to stay within their room at all times (eg newly diagnosed smear positive TB).
2. If it is necessary to attend other clinical areas for diagnostic tests or procedures appropriate standard and contact precautions must be maintained at all times by the handling staff.
3. Clinical areas receiving patients for procedures or investigations should be informed via phone call in advance of patient arrival to enable adequate preparation to manage MDRO cases e.g. allow enough time to perform terminal cleaning before the next patient
4. Post cases with Transmissible infections last on list, wherever possible.

Health care worker

1. The staff should at all times adhere to Standard Precaution practice when in contact with the patient (before , during and after transfer).
2. The staff who transports and receiving the patient should at all times adhere to Standard Precaution practice and Appropriate PPE should be worn according to the risk of transmission as outlined in section *Fundamental Principles of Infection Prevention ; section B*. when in contact with the patient (before , during and after transfer)
3. General Principles for health care workers in operating theatre.
 - a. Limit the number of people in the theatre to essential staff only whenever possible.
 - b. Theatre staff should wear the appropriate level mask when within 3 feet of the patient and use other PPE as required by Standard and Transmission based precaution.

- c. Theatre environment and equipment should be cleaned with detergent and disinfected according to manufacture guidelines. Please refer to Chapter 12: Environmental.

Patient Requirements

1. Upon transfer, patient must use appropriate barriers (e.g., mask, gown, use of impervious dressings to cover the affected area(s) over open skin lesions or drainage), consistent with the route and risk of transmission;
2. Patients should avoid using toilets outside their room however if necessary, staff should encourage the use of a commode which must be cleaned and disinfected afterwards Or dedicate a bathroom and ensure cleaning and disinfection occurs after toilet use.
3. Patient if possible should be placed in a designated waiting area and should be treated as an urgent case. If possible in a single room or maintain minimal 1m spatial separation. Or minimal 3m for patients on droplet precaution
4. Once vacated, procedure room must be terminally cleaned before readmission of another patient

Equipment and instruments/devices

1. Disposable equipment should be used where possible (e.g., tourniquet). Where this is not possible, use dedicated equipment.
2. Healthcare facilities should ensure that all reusable medical equipment (e.g. blood glucose meters and other point-of-care devices, surgical instruments, endoscopes, lifting machines) is disinfected as per manufacture requirement.
3. If equipment must be shared between patients (e.g., automated blood pressure cuffs), ensure the equipment has been disinfected before use on another patient

TRANSFER TO ANOTHER HEALTHCARE FACILITIES/ COMMUNITY LONG TERM CARE FACILITIES

Includes

- a) Admission to another hospital (Government Hospital / private Hospitals)
- b) Referral to community clinics for procedures such as wound care/ hemodialysis
- c) Referral to a long term care facility such as nursing homes/ rehabilitation care



General principles

1. When transferring patients to another health or community care setting it is vital to inform the receiving care provider using the transfer care form or via phone call if the patient has a known or suspected infection (eg contact to other patients with CRE infection). This can be done by completing the ***Inter Health Care Infection Prevention Transfer Form*** AND by a courtesy call to the receiving health care facility.
2. The Infection Prevention and Control Team must be notified prior to the transfer taking place so that they can communicate transfer details with the receiving Infection Prevention and Control Team (where applicable) in order for appropriate infection prevention and control measures be put in place to prevent the potential spread of infection to other patients, staff and visitors.
3. The staff who transports and receiving the patient should at all times adhere to Standard Precaution practice and Appropriate PPE should be worn according to the risk of transmission as outlined in section *Fundamental Principles of Infection Prevention ; section B*. when in contact with the patient (before , during and after transfer)
4. Patient transport vehicles such as ambulance should be terminally cleaned before admitting another patient.

Is the patient aware of the MDR status Yes/ No	Does the patient require Isolation
Other relevant Information	
Name of person completing the form: Designation :	Signature Date:

* to be faxed/ emailed / hard copy attached to referral letter
to be filled by referring doctors.

15

EDUCATION AND TRAINING

Healthcare facilities should provide specific education and training for all healthcare workers about infection prevention and control policies and procedures. The aim is to inform and educate healthcare workers about the infectious hazards they will face during their employment and their role in minimising the spread of infection to others. Attention should be given to advice about hand hygiene.

15.1 The role of the Hospital Director

1. Health administrators should be oriented towards the importance of the infection control programme.
2. Health administrators as advised by the Hospital Infection and Antibiotic Control Committee (HIACC) should provide appropriate training for health care workers, to include but not limited to **requisite knowledge** for good infection control practices.

15.2 The role of the Hospital Infection and Antibiotic Control Committee (HIACC)

1. Assess training needs of all staff and provide required training through awareness programmes, in-service education and on-the-job training; to include but not limited to **requisite knowledge**.
2. Organize regular training programmes for the staff for essential infection control practices that are appropriate to their job description.
3. Provide periodic re-training or orientation of staff; and review the impact of training.

15.3 The role of the infection control professionals (Infection Control Nurse)

Personnel, Infection Control Doctor / Coordinator and Ward Link Nurse)

1. Participate in informal and formal teaching programmes, for all healthcare workers.

2. Keep abreast with recent advances by reading relevant literature and attending appropriate courses, meetings and exhibitions.
3. Advise staff with regards to microbiologic hazards in occupational health safety.
4. Participate and coordinate infection control-related educational campaigns as instructed by the Hospital Infection and Antibiotic Control Committee (HIACC)
5. Disseminate, educate and create awareness on infection control to new health care workers / students in the wards.
6. Educate and create awareness on infection control to patients and visitors especially those with infectious diseases.

15.4 The role of all Health Care Workers

1. Healthcare workers should be equipped with **requisite knowledge** and skills for good infection control practices.
2. Healthcare workers should participate in informal and formal teaching programmes on Infection Control.

15.5 Training programmes to encompass Infection Control Protocols

1. All staff (both clinical and non-clinical) must be educated on Infection Control Protocol, to include but not limited to **requisite knowledge** as follows:
 - modes of transmission of infectious agents
 - risk identification, assessment and management strategies including transmission-based precautions
 - orientation to the physical work environment with a focus on its risks for infection
 - safe work procedures
 - correct use of standard precautions
 - correct choice and use of PPE, including procedures for putting on and removing PPE and fit checking (or user seal check) of respirators
 - appropriate attire (shoes/hair/nails/jewellery)
 - hand hygiene practices
 - levels of cleaning required for clinical areas and equipment
 - how to deal with spills
 - safe handling and disposal of sharps
 - reporting requirements of incidents such as sharps injuries and exposures

- waste management
- antibiotic policy and practice.

This information should be provided in the context of their roles in the organisation or practice, and with a focus on respecting and maintaining patient confidentiality at all times. It should be provided as part of their orientation, with periodic updates and refresher courses as required for their specific jobs.

2. Healthcare workers may also require job or task-specific education and training, such as:
 - the use of personal protective equipment
 - instrument cleaning and sterilisation competency testing;
 - insertion and management of central and peripheral lines; and
 - risks and prevention of MDRO transmission.

Job-specific training should be provided as part of orientation, when new procedures affect the employee's occupational exposure, before rostering to hazardous areas (e.g. caring for patients on airborne precautions in a negative pressure room); and at a minimum, in annual courses.

Healthcare workers should be assessed to ensure that they are competent in using and consistently adhering to the specific infection prevention and control practice whenever possible. Healthcare facilities should maintain records of participation by healthcare workers in infection prevention and control education programs.

15.6 Education strategies

1. The term 'educational strategies' encompasses a wide range of commonly applied interventions that aim to bring about and sustain changes in the practice of healthcare workers.
2. Education activities may include:

(Adapted from the Australian guidelines for the prevention and control of infection in healthcare. (2010))

 - a. educational meetings, either didactic (e.g. lecture, presentation) or interactive (e.g. workshop with role play and case discussion);
 - b. educational materials, either printed or audiovisual;
 - c. educational outreach, where an intervention is delivered by a visiting infection prevention and control expert;

- d. continuing medical education;
 - e. multifaceted, tailored interventions to address barriers to good practice
 - f. inter-professional education; and
 - g. simulation exercise.
3. Education activities can be integrated into staff orientation programs, credentialing packages, annual training and competency testing, implementation of policy and procedure manuals.
4. The infection control professionals' contact details should be readily available to all staff and included in all resources.

APPENDIX

ISO 14644-1 Cleanroom Standards

Class	Maximum Particles / m ³						FED STD 209E equivalent
	≥ 0.1 µm	≥ 0.2 µm	≥ 0.3 µm	≥ 0.5 µm	≥ 1 µm	≥ 5 µm	
ISO 1	10	2					
ISO 2	100	24	10	4			
ISO 3	1,000	237	102	35	8		Class 1
ISO 4	10,000	2,370	1,020	352	83		Class 10
ISO 5	100,000	23,700	10,200	3,520	832	29	Class 100
ISO 6		237,000	102,000	35,200	8,320	293	Class 1,000
ISO 7				352,000	83,200	2,930	Class 10,000
ISO 8				3,520,000	832,000	29,300	Class 100,000
ISO 9				35,200,000	8,320,000	293,000	Room Air

REFERENCES

- A Handbook of Infection Control for Asian Healthcare worker. 3rd Edition
- A.S.P.E.N Enteral Nutrition Handbook 2010
- Ahn, C. and R.S. Salcido, Advances in wound photography and assessment methods. *Advances in Skin & Wound Care*, 2008. 21(2): p. 85-95.
- AIDS Series Documents: Guidelines on the Management of Infected Healthcare Workers published by the Ministry of Health Malaysia 1995
- Alberta health services IPC best practice guidelines 2015
- ANSI/ASHRAE/ASHE Standard 170-2017: Ventilation of Health Care Facilities
- APSIC Guidelines for Environmental Cleaning and Decontamination
- ASPEN 2013 Safety Consensus on Parental Nutrition
- Australian Wound Management Association (AWMA) and New Zealand Wound Care Society (NZWCS), Australia and New Zealand Clinical Practice Guideline for Prevention and Management of Venous Leg Ulcers. 2012 Cambridge Media: Osborne Park, WA.
- Australian Wound Management Association (AWMA), Pan Pacific Clinical Practice Guideline for the Prevention and Management of Pressure Injury. 2012, Cambridge Media: Osborne Park, WA.
- Australian guidelines for the prevention and control of infection in healthcare. (2010).
- Avni T, Levcovich A, Ad-El DD, Leibovici L, Paul M. Prophylactic antibiotics for burns patients: systematic review and meta-analysis. *The BMJ*. 2010;340:c241. doi:10.1136/bmj.c241.
- Berg RD. Bacterial translocation from the gastrointestinal tract. *Trends in microbiology*. 1995 Apr 1;3 (4):149-54.
- Best Practices Guidelines for Occupational Health and Safety in the Healthcare Industry- Work Safe Alberta https://work.alberta.ca/documents/WHS-PUB_bp010.
- Breast Feeding Guideline WHO/UNICEF 2009

- Centers for Disease Control and Prevention. MMWR, April 27 2001; vol. 50. Recommendations for preventing transmission of infections among chronic hemodialysis patients
- Central Venous Catheter Care Bundle Compliance Surveillance manual (2016) for methodology, definitions and data management
- David K. Henderson, MD; Louise Dembry, MD, MS, MBA; Neil O. Fishman, MD; Christine Grady, RN, PhD; Tammy Lundstrom, MD, JD; Tara N. Palmore, MD; Kent A. Sepkowitz, MD; David J. Weber, MD, MPH; for the Society for Healthcare Epidemiology of America SHEA Guideline for Management of Healthcare Workers Who Are Infected with Hepatitis B Virus, Hepatitis C Virus, and/or Human Immunodeficiency Virus: Infection control and hospital epidemiology. vol. 31, no. 3 March 2010.
- Dept of Health UK Advice for specialties
- Disinfectant Manual 2018-MOH Malaysia
- DOE Documents: Guidelines on Handling and Management of Clinical Waste in Malaysia 2009
- Epidemiology of Invasive Fungal Infections in the Intensive Care Unit ,M.T Montagna et al, Infection. 2013 June; 41(3):645-653
- Food Hygiene Regulations; 2009
- Garis Panduan Pelaksanaan Program Imunisasi Hepatitis B Bagi Anggota Kementerian Kesihatan Malaysia; Unit Kesihatan Pekerjaan, Bahagian Kawalan Penyakit, KKM; 2011.*
- Garis Panduan Pengurusan Wabak Tifoid di Malaysia (Jilid 2); Kementerian Kesihatan Malaysia; 2006.*
- Gatt M, Reddy BS, MacFie J. Bacterial translocation in the critically ill—evidence and methods of prevention. Alimentary pharmacology & therapeutics. 2007 Apr 1;25(7):741-57.http://www.iccueducation.org.uk/uploads/2/3/1/0/23109338/gut_translocation_article.pdf
- General Medical Council: Supplementary Guidance on Good Medical Practice. "Healthcare workers who have, or may have, a serious communicable disease", Sept 2009
- Global Guidelines for the Prevention of Surgical Site Infection, WHO 2016.

- Guideline for infection control in healthcare personnel available at: <http://www.cdc.gov/hicpac/pdf/InfectControl98.pdf>
- Guideline On Conceptual Design And Engineering Requirements For Isolation Room
Ministry of Health, 1st edition, 2017
- Guidelines for Adult Immunisation, 2nd Edition, Malaysian Society of Infectious Diseases and Chemotherapy; 2014.
- Guidelines for Environmental Infection Control in Health-Care Facilities, CDC 5th Nov 2015
- Guidelines for Environmental Infection Control in Health-Care Facilities. Recommendations of CDC and the Healthcare Infection Control Practices Advisory Committee (HICPAC) 2003. *updated Feb 15, 2017*
- Guidelines for Environmental Infection Control in Health-Care Facilities. Recommendations of CDC and the Healthcare Infection Control Practices Advisory Committee (HICPAC) 2003. *updated Feb 15, 2017*
- Guidelines for Hospital Catering, 2010, Food Safety and Quality Division, Ministry of Health Malaysia.
- Guidelines for Oral Healthcare Practitioners infected with Blood-Borne viruses. Malaysian Dental Council. 2007
- Guidelines for Preventing Infectious Complications among Hematopoietic Cell Transplantation Recipients: A Global Perspective Marcie T et al, American Society for Blood and Marrow Transplant 15:1143-1238 (2009)
- Guidelines for Preventing Opportunistic Infections Among Hematopoietic Stem Cell Transplant Recipients available at: <http://www.cdc.gov/mmwr/preview/mmwrhtml/rr4910a1.htm>
- Guidelines for Preventing the Transmission of Mycobacterium Tuberculosis In Health-Care Settings, 2005. MMWR Recommendations and Report. CDC, 30th December 2005 / 54(RR17)
- Guidelines for Preventing the Transmission of Mycobacterium Tuberculosis In Health-Care Settings, 2005. MMWR Recommendations and Report. CDC, 30th December 2005 / 54(RR17)
- Guidelines on Indoor Air Quality for Hospital Support Service (2015). Engineering Services Division, Ministry of Health Malaysia.

- Handling Clean Linen in a Healthcare Environment www.hygeinicallyclean.org
- Harris DM: Biological Safety. In Cotton DWK, Cross SS (eds): The Hospital Autopsy. DWK Cotton, SS Cross. Butterworth-Heinemann Ltd, 1993. pp15-29.
- Hart DW, Wolf SE, Chinkes DL, Beauford RB, Mlcak RP, Hegggers JP, et al. Effects of early excision and aggressive enteral feeding on hypermetabolism, catabolism, and sepsis after severe burn. *J Trauma*. 2003;54:755-61.
- Hayek S., El Khatib A., Atiyeh B.; Burn Wound Cleansing – A Myth of Scientific Practice. *Annals of Burns and Fire Disasters* – vol. XXIII – n. 1 – March 2010
- HIV Infected Healthcare Workers: Guidance on Management and Patient Notification. Department of Health UK, 2005
- HIV post-exposure prophylaxis - guidance from the UK Chief Medical Officers Expert Advisory Group on AIDS, Dept of Health (September 2008)
- Hospital Sultanah Bahiyah: Biosafety Level 3 (BSL-3) Work Procedure Manual (2009)
- <http://www.nhs.uk/Conditions/HIV/Pages/Introduction.aspx>
- <https://www.pharmacy.gov.my/v2/en/documents/national-antibiotic-guideline-nag-2nd-edition.html>
- HVAC Design Manual for Hospitals and Clinics, 2nd Edition (2013)
- Infection Prevention and Control Audit manual (2016), MOH
- Isabelle Lavedrine, Patric Thomas, James Tharp, Jerry Sipes ; Innovative Design Solutions For Burn Intensive Care Unit; 9th International IBPSA Conference, Building Simulation 2005
- Joan Weber, Albert McManus; Infection control in burn patients, *BURNS* 30 (2004)
- Kates SG, McGinley KJ, Larson EL, Leyden JJ. Indigenous multiresistant bacteria from flowers in hospital and nonhospital environments. *Am J Infect Control*. 1991;19:156-61.
- KDIGO Clinical Practice Guideline for the Prevention, Diagnosis, Evaluation, and Treatment of Hepatitis C in CKD
- Laundry policy RDaSH, NHS Foundation Trust, 30th October 2017(references to concession agreement & MAP – Master Agreed Procedure / POG – Project Operational Guidelines)

- Lochaitis A., Chalikitis S., Tzortzis C. Hydrotherapy (Bath Therapy) As A Treatment Option In Burns; *Annals of the MBC - vol. 5 - n' 2 - June 1992*
- Malaysian Standards, 2007, MS 1480:2007, Food Safety According to Hazard Analysis AND Critical Control Point (HACCP) System (First Revision), Department of Standards Malaysia.
- Malaysian Standards, 2009, MS 1514:2009, Good Manufacturing Practice (GMP) for Food (First Revision), Department of Standards Malaysia.
- Management of Healthcare Workers Infected with Hepatitis B Virus, Hepatitis C Virus, Human Immunodeficiency Virus, and Other Blood borne Pathogens: SHEA Positions Paper. *Infection Control and Hospital Epidemiology*: Vol. 18 No. 5. May 1997
- Manual for MDRO & MRSAB surveillance 2nd edition (2017) for methodology, case definition and data management for surveillance
- Manual For Sterile Preparation, Pharmaceutical Services Division, August 2010
- Manual PPS for HA-BSI 2nd edition(2015) for methodology, case definition and data management for surveillance
- Medical Development Division and Pharmacy Practice and Development Division, Ministry of Health Malaysia. Protocol for Point Prevalence Survey on Healthcare Associated Infections and Antibiotic Utilisation. 2018.
- Mehta Y, Gupta A, Todi S, et al. Guidelines for prevention of hospital acquired infections. *Indian Journal of Critical Care Medicine*: Peer-reviewed, Official Publication of Indian Society of Critical Care Medicine. 2014;18(3):149-163. doi:10.4103/0972-5229.128705.
- Ministry of Health Malaysia. Protocol on Antimicrobial Stewardship in Healthcare Facilities. Second Edition. 2018.
- National Hazard Exposure Worker Surveillance: Exposure To Biological Hazards and The Provision of Controls Against Biological Hazards In Australian Workplaces - Safe Work Australia https://www.safeworkaustralia.gov.au/system/files/.../nnews_biologicalmater
- National Influenza Preparedness Plan (NIPPP), Ministry of Health Malaysia; 2006.
- National Institute of Forensic Medicine: Standard Requirements for Mortuary and Post-mortem Facility (2011).

National Pressure Ulcer Advisory Panel (NPUAP), European Pressure Ulcer Advisory Panel (EPUAP), and Pan Pacific Pressure Injury Alliance (PPPIA), Prevention and Treatment of Pressure Ulcers: Clinical Practice Guideline. 2014: Emily Haesler (Ed.) Cambridge Media: Osborne Park, WA

Nephrology Services Operational Policy 2017

Occupational Safety and Health Administration (OSHA) United States

Oxford University Hospitals NHS Foundation Trust: Hepatitis B immunization for people with Chronic Kidney Disease

Panduan Spesifikasi Bahan Makanan untuk Perkhidmatan Dietetik dan Sajian di Hospital Kementerian Kesihatan Malaysia. Edisi 1 Tahun 2015.

Patient Areas and Environmental Cleaning, Guide to infection control in the hospital, Chapter 8, International Society of Infectious Disease. Updated: March, 2018

Pengurusan Sisa Klinikal di Fasiliti Kesihatan KKM, Seksyen Operasi Klinik Bahagian Perkhidmatan Kejuruteraan Kementerian Kesihatan Malaysia September 2016

Peritoneal Dialysis Piawaian Prosedur Kerja Kementerian Kesihatan Malaysia 2015

Pharmaceutical Service Division, Ministry of Health Malaysia: National Antibiotic Guidelines, 2nd ed., 2014

Pharmacy Practice and Development Division, Ministry of Health Malaysia. *Survelan Penggunaan Antibiotik Kebangsaan: Manual Penerangan & Pengisian Data bagi Hospital dan Klinik Kesihatan Kementerian Kesihatan Malaysia. 2018.*

Pharmacy Practice and Development Division, Ministry of Health Malaysia. *Surveillance Penggunaan Antibiotik Kebangsaan: Manual Penerangan & Pengisian Data bagi Hospital-hospital. 2018.*

Point Prevalence Survey for Healthcare Associated Infection & Antibiotics, 3rd Edition 2018

Polisi dan Garispanduan Audit Kepatuhan Hand Hygiene, MOH 2013

Quality Medical Care Section, Medical Development Division, Ministry of Health Malaysia. Policies and Procedures on Infection Control. Second Edition. 2010.

Renal Replacement Therapy Clinical Practice Guideline 4th Edition

Scottish Government Guidelines on AIDS in healthcare Workers

- Scottish Government. Health Clearance for Tuberculosis, Hepatitis B, Hepatitis C and HIV for New Healthcare Workers with Direct Clinical Contact with Patients. (pdf)
- Sehulster L, Chinn RY. Guidelines for environmental infection control in health-care facilities. Recommendations of CDC and the Healthcare Infection Control Practices Advisory Committee (HICPAC). MMWR Recomm Rep. 2003;52:1-42
- Slow Moving But Deadly Infection at New Orleans Hospital Linked to Linens, Environment of Care Leader, May 26, 2014.
- Surat Pekeliling Ketua Pengarah Kesihatan Malaysia Bil. 11/2010: *Perlaksanaan Aktiviti Pencegahan dan Pengawalan Pandemik Influenza A (H1N1) di Malaysia: a) Keperluan Pelalihan Vaksin Pandemic Influenza A (H1N1) Kepada Petugas Barisan Hadapan; b) Laporan Kematian Kes Disyakki H1N1; dan c) Prosedur Penutupan Sekolah / Institusi; 29 April 2010.*
- Tatacara Perlaksanaan Proses Saringan Tibi bagi anggota Kementerian Kesihatan- Pekeliling Ketua Pengarah Kesihatan Bil 9/2012)
- The ANSI/AAMI/ISO 11140-1:2005, definition out of the ISO11140 - 1, 2005, Sterilization of health care products - Chemical indicators - Part 1: General requirements
- The Approved List of Biological Agents. Advisory Committee on Dangerous Pathogens. Health and Safety Executive, United Kingdom. www.hse.gov.uk/pubns/misc208.pdf.
- The Asean Guidelines For Disinfection And Sterilization Of Instruments In Health Care Facilities
- The National Infection Prevention and Control Guideline for Acute Healthcare Facilities 2017. Ministry of Health Singapore.
- The National Institute of Health. Biohazard Agent Classification-Caltech Safety. www.safety.caltech.edu/documents/22-biohazard_agent_classification.pdf.
- Transfusion Practice Guidelines for Clinical and Laboratory Personnel 2016 (MOH)
- WHO Hand Hygiene Self-Assessment Framework 2010
- World Health Organization. Antimicrobial resistance: Surveillance of antimicrobial use. [Online] Available from: <http://www.who.int/antimicrobial-resistance/global-action-plan/optimize-use/surveillance/en/> [Assessed 13th July 2017].
- World Health Organization. Global Action Plan on Antimicrobial Resistance. 2015 [cited 5 September 2017]. Available from: http://www.wpro.who.int/entity/drug_resistance/resources/global_action_plan_eng.pdf GAP.

The background is a teal color with a pattern of white molecular structures (represented by circles and lines) and faint images of laboratory glassware, including beakers and test tubes. The text is centered in the lower half of the image.

**Medical Development Division,
Ministry of Health Malaysia
2019**

3rd Edition